

| IDX | PART NO. | DESCRIPTION | QTY |
|-----|-------------|--------------------------------|-----|
| AA | 18-30HD5 | LD 36" HDPE HANDHOLE | |
| B | 20FRM-PE-DL | 20" POLY FRAME | |
| C | ESS19NC | 19.5" X 1.25" COVER/LID | |
| D | 1912HD5 | LD 12" HDPE HANDHOLE EXTENSION | |

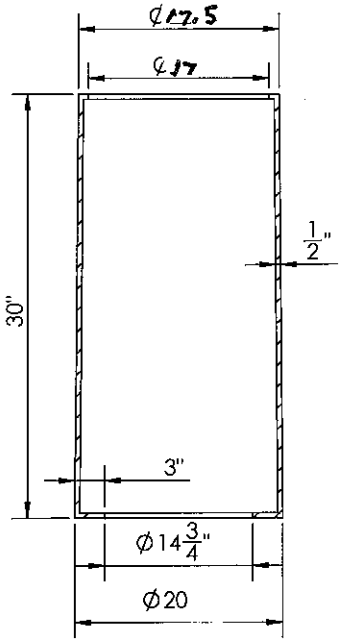

AA - 18-30HD5 HANDHOLE
(1830HD5)

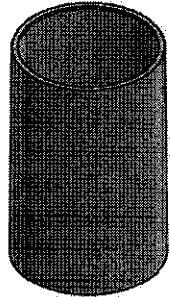
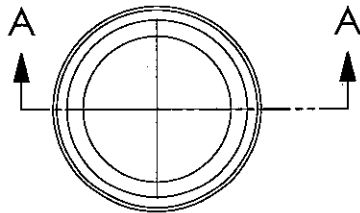
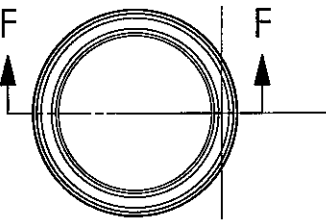

B - 20FRM-PE-DL

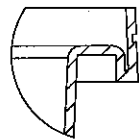

DETAIL G
SCALE 1 : 4

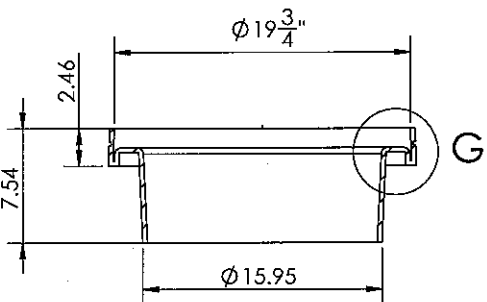

SECTION F-F
SCALE 1 : 8

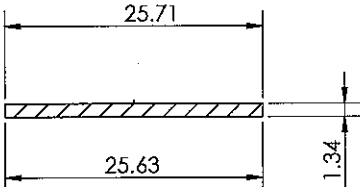
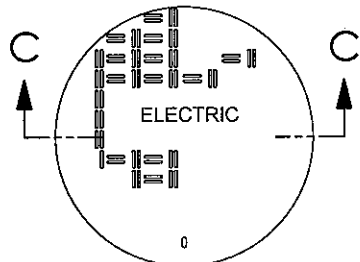

C - ELECTRIC COVER/LID
(ESS19NC.)

7/18/22

ESS
 BROTHERS AND SONS, INC.
 PHONE (763) 478-2027
 FAX (763) 478-8868

JOB: COMPOSITE ELECTRICAL PRODUCT ORDER FORM
 LOCATION: ESS BROTHERS
 CONTRACTOR: ESS JOB NO. 1 OF 1
 DATE DRAWN: 4/16/2021
 DRAWN BY: DM. CHECKED BY: NGN
 REVISION DESCRIPTION: DATE: 12/29/17
 DATE: 12/29/17

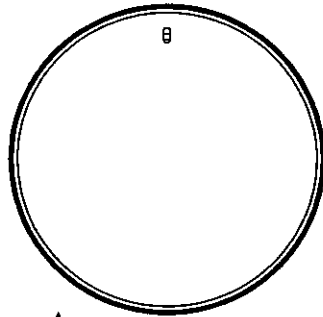

A ←

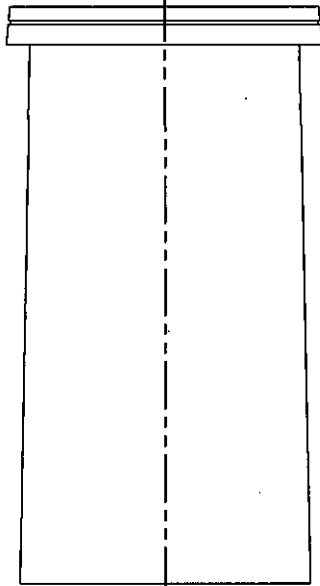

← A

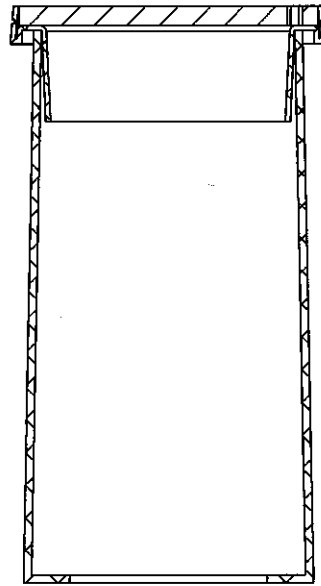

SECTION A-A
SCALE 1 : 12

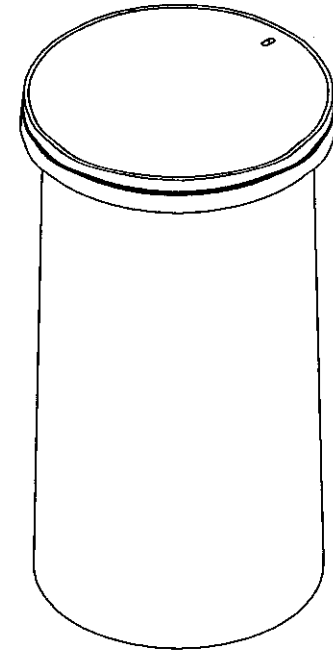

DISCLAIMER

Stern Companies makes no representation or warranties, express or implied, with respect to the reuse of this data. There is no guarantee or representation to the user as to the accuracy, suitability or reliability of this data for any purpose. The user accepts the data "as is", and assumes all risks associated with its use. Stern Companies takes no responsibility for actual or consequential damage incurred as a result of any user's reliance on this data.

Authorized Company Representative:

| | | | | | |
|--------------------------------------|--|-----------|------|--|--------------|
| UNLESS OTHERWISE SPECIFIED: | | NAME | DATE | COMPANY: Stern Companies Inc | |
| DIMENSIONS ARE IN INCHES | | DRAWN | | TITLE: 18" Barrel-Frame-Cover Assembly | |
| TOLERANCES: | | CHECKED | | | |
| FRACTIONAL ± 1/8 | | ENG APPR. | | | |
| ANGULAR: ± 1 | | MFG APPR. | | | |
| TWO PLACE DECIMAL ± .10 | | Q.A. | | SIZE | DWG. NO. |
| THREE PLACE DECIMAL ± .060 | | COMMENTS: | | A | |
| INTERPRET GEOMETRIC TOLERANCING PER: | | | | | REV |
| MATERIAL | | | | | 01 |
| FINISH | | | | SCALE: 1:12 | WEIGHT: |
| DO NOT SCALE DRAWING | | | | | SHEET 1 OF 1 |

5

4

3

2

1