

APPROVED
Alexander Crabtree
11/02/2018

DEVICE	DESCRIPTION	PROJ. AREA (FT ²)	WEIGHT (LBS)
(A)	MITIGATOR TR1 MAST ARM VIBRATION DAMPER	1.20	37
(B)	12"-4 SEC. SIGNAL WITH BACKPLATES	11.00	70
(C)	30" X 36" SIGN	7.50	15
(D)	12"-3 SEC. SIGNAL WITH BACKPLATES	8.67	60
(E)	108" X 36" STREET NAME SIGN	13.50	85
(F)	12"-5 SEC. SIGNAL WITH BACKPLATES	13.33	85
(G)	4 SEC./3 SEC. SIGNAL WITH BACKPLATES	19.37	130
(H)	POLE MOUNTED PED SIGNAL	2.74	28
(I)	36" X 36" SIGN	9.00	30
(J)	30" X 30" FOLDING STOP SIGN	6.25	20
(K)	5 SEC / 4 SEC / 3 SEC SIGNAL WITH BACKPLATES	26.66	210

MAXIMUM LOADING INFORMATION

THE MAST ARM TRAFFIC STRUCTURES SHOWN ON THIS DRAWING HAVE BEEN DESIGNED IN ACCORDANCE WITH THE LOADING AND THE NOMINAL STRENGTH REQUIREMENTS OF THE 2015 AASHTO LRFD SPECIFICATIONS FOR STRUCTURAL SUPPORTS FOR HIGHWAY SIGNS, LUMINAIRES AND TRAFFIC SIGNALS, FIRST EDITION" SLTS-1. THE WIND LOADS WERE CALCULATED FROM AN ULTIMATE WIND VELOCITY OF 115 MPH WITH A MEAN RECURRENCE INTERVAL OF 700 YEARS, AND A FATIGUE CATEGORY OF 2. THE FATIGUE LOADS WERE CALCULATED ON THE REQUIREMENTS OF SECTION 11 OF THE CODE, AND THE FOLLOWING DESIGN CONDITIONS:

- STRUCTURES ARE DESIGNED TO RESIST NATURAL WIND GUSTS BASED ON THE YEARLY MEAN WIND VELOCITY OF 11.2 MPH.
- STRUCTURES ARE NOT DESIGNED TO RESIST GALLOPING-INDUCED CYCLIC LOADS.
- STRUCTURES ARE DESIGNED FOR TRUCK-INDUCED GUST LOADS, AS REQUIRED BY THE OWNER OF THE STRUCTURES.

AASHTO 2015 SPECIFICATIONS

MATERIAL DATA					
COMPONENT	ASTM DESIGNATION	MIN. YIELD (KSI)	COMPONENT	ASTM DESIGNATION	MIN. YIELD (KSI)
TAPERED TUBES	A595 GR. A OR A572	55	LUMINAIRE ARM ATTACH. LUM. ARM CONN. BOLTS	A36 A325*	36
POLE BASE	A572 GR.50	50	ANCHOR BOLTS W/ SUPPLEMENTARY SPEC S4	F1554 GR.55	55
SIGNAL ARM ATTACHMENT	A36	36	ANCHOR BOLT TEMPLATE	A36	36
SIGNAL ARM CONN. BOLTS	A325*				
GALVANIZING STRUCTURE	A123				
GALVANIZING HARDWARE	HOT DIP ZINC				

* LUBRICATE IN THE FIELD IF NECESSARY

LUMINAIRE ARM DATA					
ARM SPAN "L" (FT)	FIXED END DIA. (IN)	FREE END DIA. (IN)	GAUGE	RISE "R" (FT)	
6.00	3.39	2.40	11	3.00	
8.00	3.63	2.40	11	3.00	
10.00	3.88	2.40	11	3.00	
12.00	4.16	2.40	11	3.00	
15.00	4.58	2.40	11	3.00	

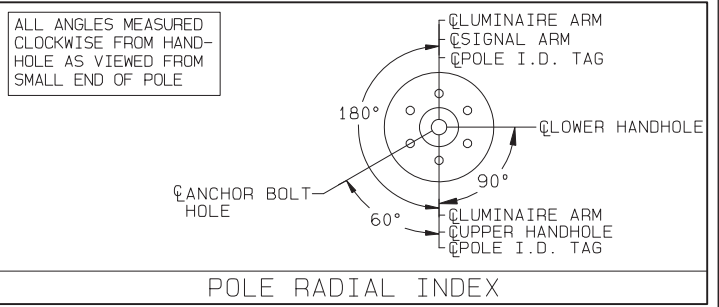
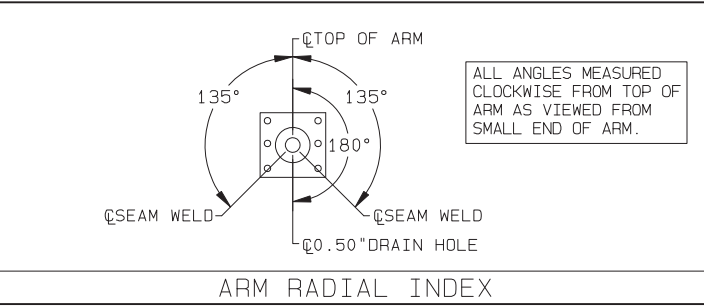

POLE AND SIGNAL ARM DATA																		
STRUCTURE TYPE	POLE TUBE				POLE BASE				ANCHOR BOLT DATA					SIGNAL ARM TUBE				
	BASE DIA. (IN)	TOP DIA. (IN)	LENGTH (FT)	GAUGE OR THK. (IN)	ROUND DIA "R" (IN)	BOLT CIRCLE "Y" (IN)	THK. "M" (IN)	CENTER HOLE "P" (IN)	BOLT HOLE "Z" (IN)	DIA. "K" (IN)	LENGTH "J" (IN)	THREAD LENGTH "U1" (IN)	THREAD LENGTH "U2" (IN)	ANCHOR BOLT QTY.	FIXED END DIA. (IN)	FREE END DIA. (IN)	GAUGE OR THICK (IN)	SPAN (FT)
TYPE 9 (SPECIAL)	13.00	10.06	21.00	3	22.00	18.00	2.00	11.25	1.75	1.50	52.00	10.00	5.50	6	11.00	6.10	7	35.00
															11.00	5.40	7	40.00
															11.50	5.20	7	45.00
TYPE 10 (SPECIAL)	13.00	8.80	30.00	3	22.00	18.00	2.00	11.25	1.75	1.50	52.00	10.00	5.50	6	11.00	6.10	7	35.00
															11.00	5.40	7	40.00
															11.50	5.20	7	45.00

Digitally signed by
NIZAM A QASSEM
Date: 2018-10-23 14:19:05:00

WISCONSIN PROFESSIONAL ENGINEER
NIZAM A QASSEM
E-41317
OMAHA NE

REV	DRAWN BY-DATE	CHECK BY-DATE	DESCRIPTION
A	AH7 10/22/18	NKL 10/23/18	ROTATED LOWER HH/ REVISED RADIAL INDEX
	AH7 09/14/18	NKL 09/27/18	

TITLE WISCONSIN DEPARTMENT OF TRANSPORTATION
TYPE 9 SPECIAL & TYPE 10 SPECIAL TRAFFIC SIGNAL STRUCTURES
AASHTO 2015

VALMONT INDUSTRIES, INC. RESERVES THE RIGHT TO INSTALL VARIOUS, ENGINEER APPROVED, MATERIAL HANGING ACCOMMODATIONS TO FACILITATE THE MANUFACTURING PROCESS.



PAGE NUMBER: 1 OF 3	REV
DRAWING NUMBER	DB01268
	A

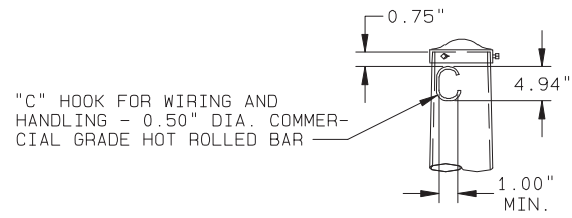

DETAIL 1 POLE TOP

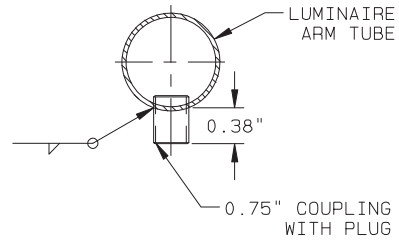

DETAIL 2 LUMINAIRE ARM COUPLING

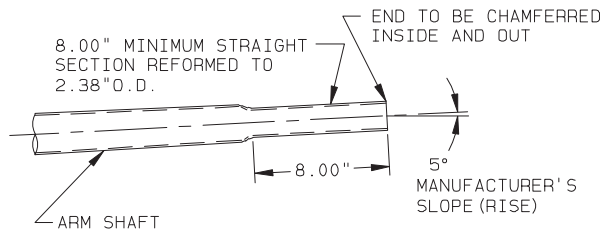

DETAIL 3 LUMINAIRE ARM END REFORMED

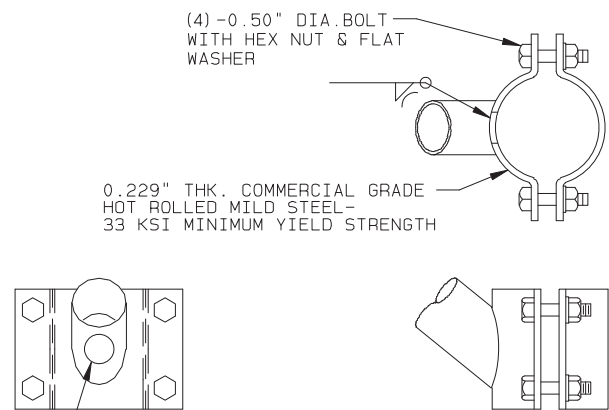

DETAIL 4 LUMINAIRE ARM ATTACHMENT (OPTIONAL)

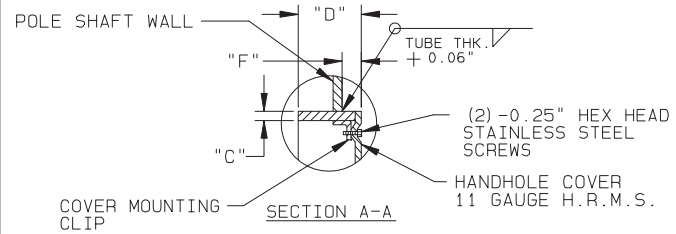

DETAIL 5 UPPER HANDHOLE

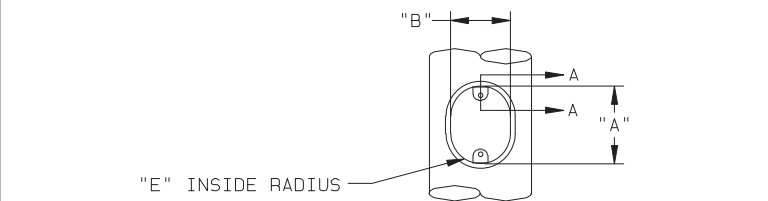

DETAIL 5 UPPER HANDHOLE

POLE TYPE	"A" I.D. (IN)	"B" I.D. (IN)	"C" THK (IN)	"D" DEPTH (IN)	"E" RADIUS (IN)	"F" PROJ. (FT)
9 SPECIAL	6.69	4.00	0.250	2.00	2.00	0.50
10 SPECIAL	6.69	4.00	0.250	2.00	2.00	0.50

DETAIL 5 UPPER HANDHOLE

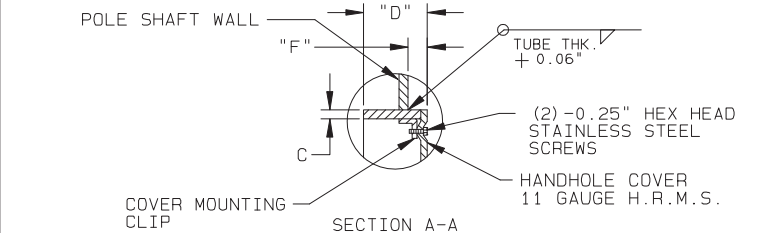

DETAIL 6 LOWER HANDHOLE



DETAIL 6 LOWER HANDHOLE

POLE TYPE	"A" I.D. (IN)	"B" I.D. (IN)	"C" THK (IN)	"D" DEPTH (IN)	"E" RADIUS (IN)	"F" PROJ. (IN)	"H" MTG. HEIGHT (FT)
9 SPECIAL	10.00	5.00	0.375	4.00	2.50	0.50	1.61
10 SPECIAL	10.00	5.00	0.375	4.00	2.50	0.50	1.61

DETAIL 6 LOWER HANDHOLE

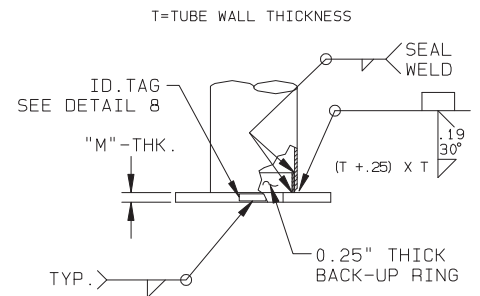

DETAIL 7 POLE BASE

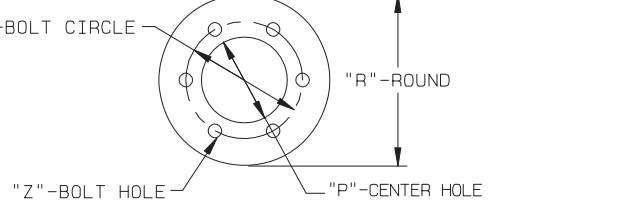

DETAIL 7 POLE BASE

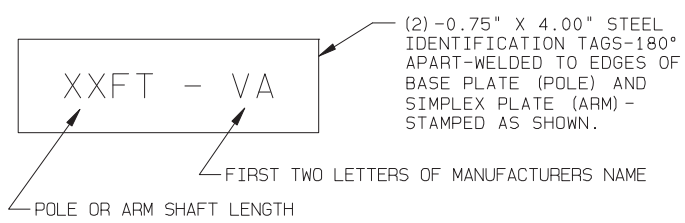

DETAIL 8 IDENTIFICATION TAG

(6) -ANCHOR BOLTS WITH
(5) -HEX NUTS AND
(2) -WASHERS PER BOLT
GALVANIZED FULL LENGTH.

STRUCTURE TYPE	PROJECTION (IN)
9 SPECIAL	9.00
10 SPECIAL	9.00

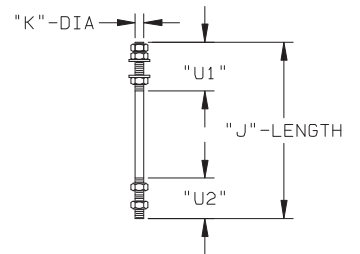

DETAIL 9 ANCHOR BOLT

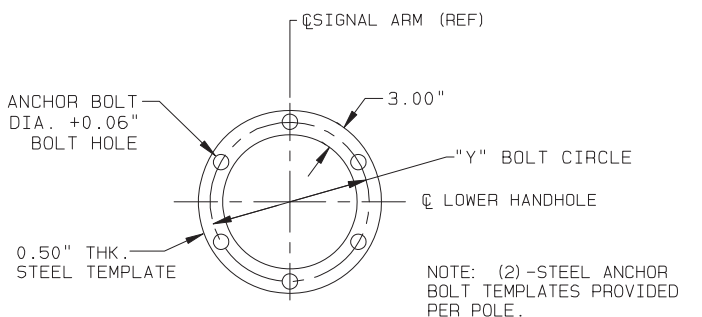

DETAIL 10 TYPE 9/10 -ANCHOR BOLT TEMPLATE

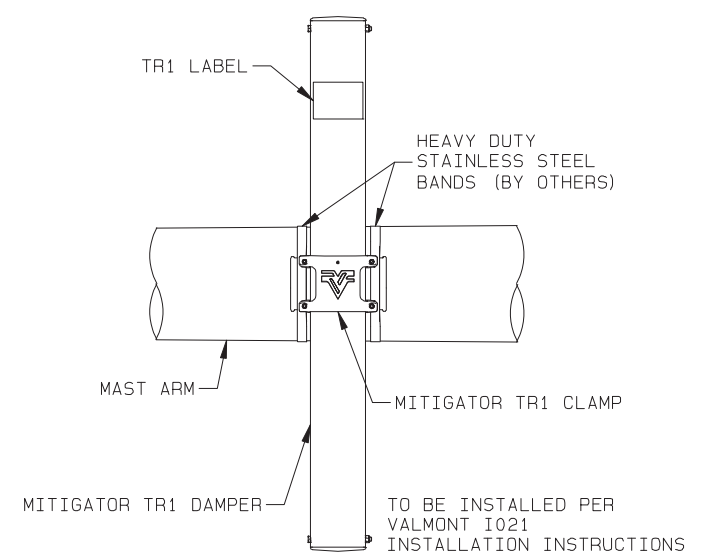

DETAIL 11 TR1 MITIGATOR

ALTHOUGH RARE, VIBRATIONS SEVERE ENOUGH TO CAUSE DAMAGE CAN OCCASIONALLY OCCUR IN STRUCTURES OF ALL TYPES. BECAUSE THEY ARE INFLUENCED BY MANY INTERACTING VARIABLES, VIBRATIONS ARE GENERALLY UNPREDICTABLE. THE USER'S MAINTENANCE PROGRAM SHOULD INCLUDE OBSERVATION FOR EXCESSIVE VIBRATION AND EXAMINATION FOR ANY STRUCTURAL DAMAGE OR BOLT LOOSENING. THE VALMONT WARRANTY SPECIFICALLY EXCLUDES FATIGUE FAILURE OR SIMILAR PHENOMENA RESULTING FROM INDUCED VIBRATION, HARMONIC OSCILLATION OR RESONANCE ASSOCIATED WITH MOVEMENT OF AIR CURRENTS AROUND THE PRODUCT.

DETAIL 11 TR1 MITIGATOR

APPROVED
Alexander Crabtree
11/02/2018



Digitally signed by
NIZAM A QASSEM
Date: 2018-10-23
14:19:05:00

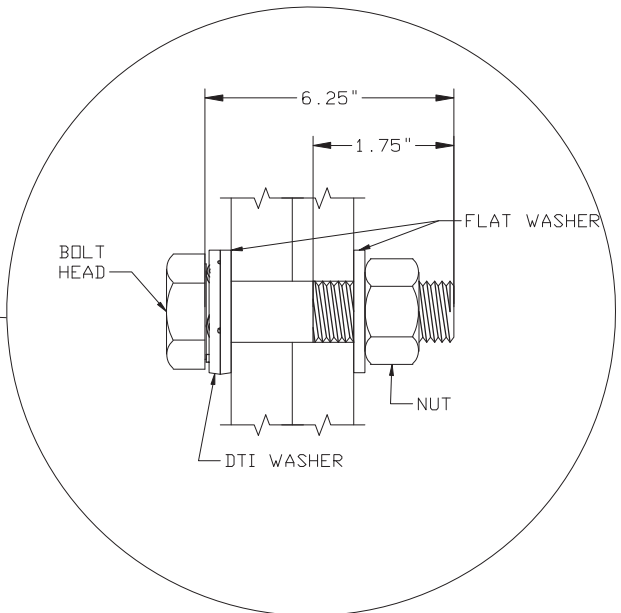
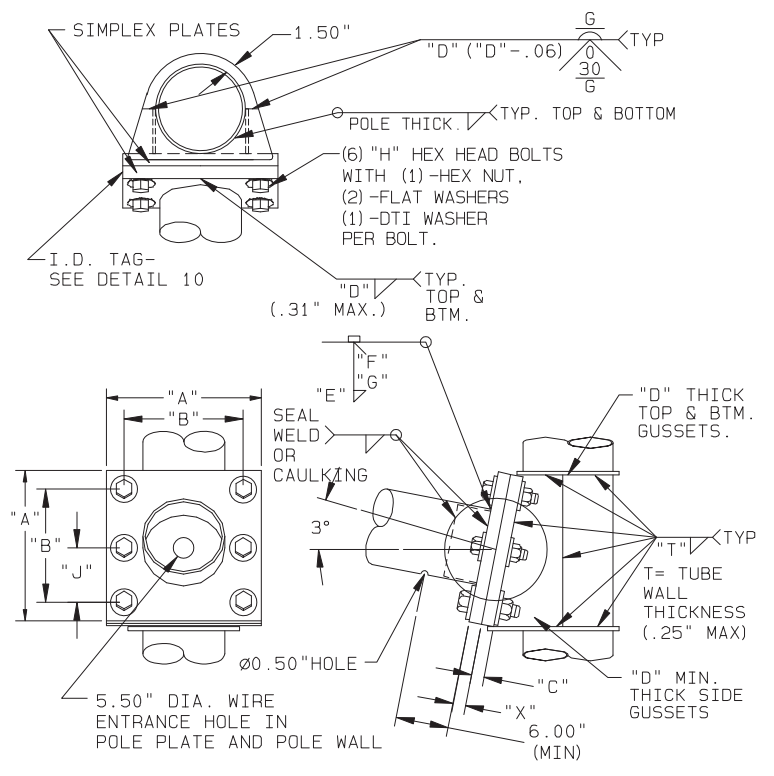

TYPE 10 SPECIAL POLES
 COVER PLATES WILL BE PROVIDED FOR UNUSED LUMINAIRE ARM CONNECTIONS

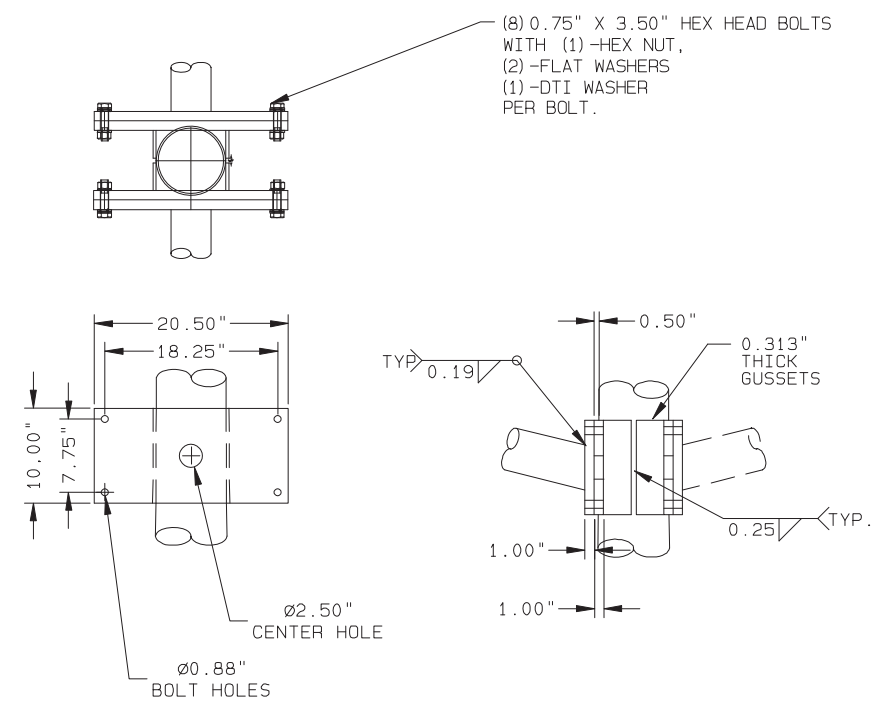

ARM TO PLATE WELD "E"	BEVEL SIZING "F"X"G"
(ARM THICK. + .25") X ARM THICK.	.19" X 30°
DETAIL 12 TYPE 9/10 SPECIAL SIGNAL ARM ATTACHMENT	

DETAIL 13 TYPE 10 SPECIAL - LUMINAIRE ARM ATTACHMENT

ARM SPAN (FT)	"A" (IN)	"B" (IN)	"J" (IN)	POLE PLATE "C" (IN)	ARM PLATE "X" (IN)	"D" (IN)	CENTER HOLE DIA. (IN)	"H" (IN)
35.00	18.75	15.50	7.75	2.00	2.25	0.375	7.00	1.00 X 6.25
40.00	18.75	15.50	7.75	2.00	2.25	0.375	7.00	1.00 X 6.25
45.00	18.75	15.50	7.75	2.00	2.25	0.375	7.00	1.00 X 6.25

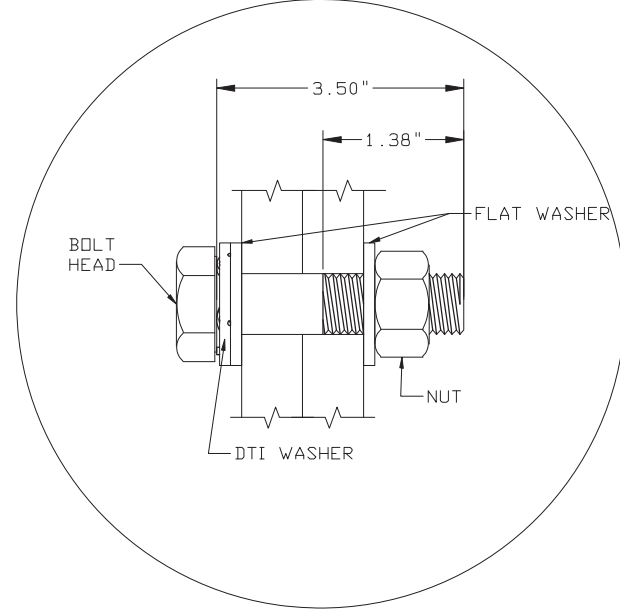

APPROVED
Alexander Crabtree
 11/02/2018



Digitally signed by
 NIZAM A QASSEM
 Date: 2018-10-23
 14:18-05:00

RECOMMENDED BOLT ASSEMBLY

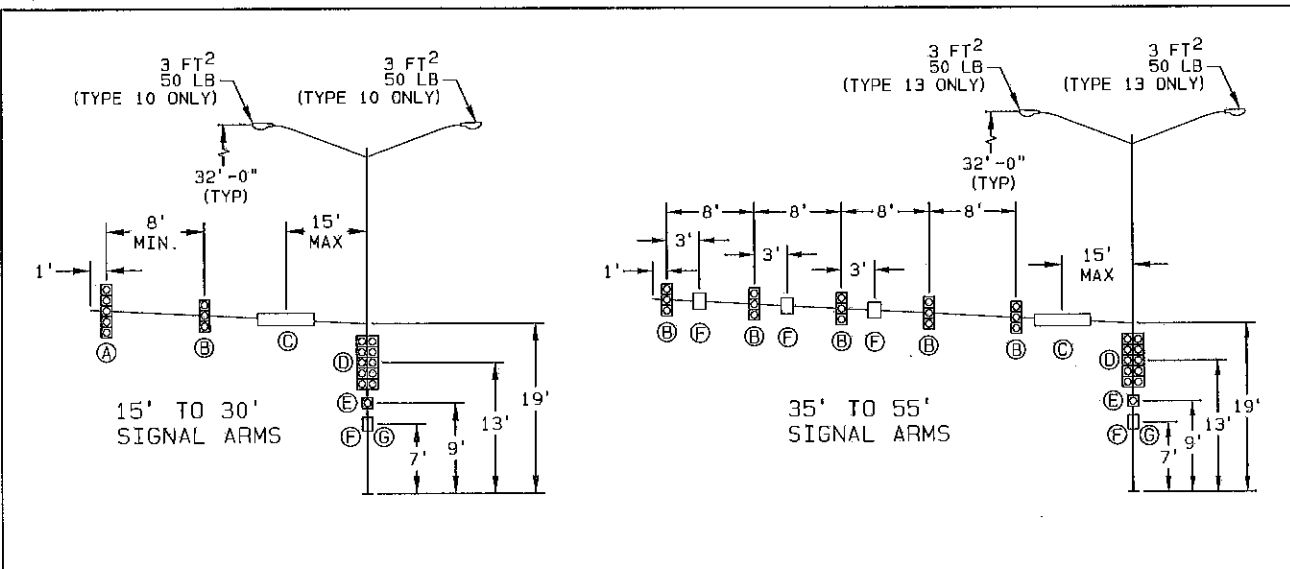
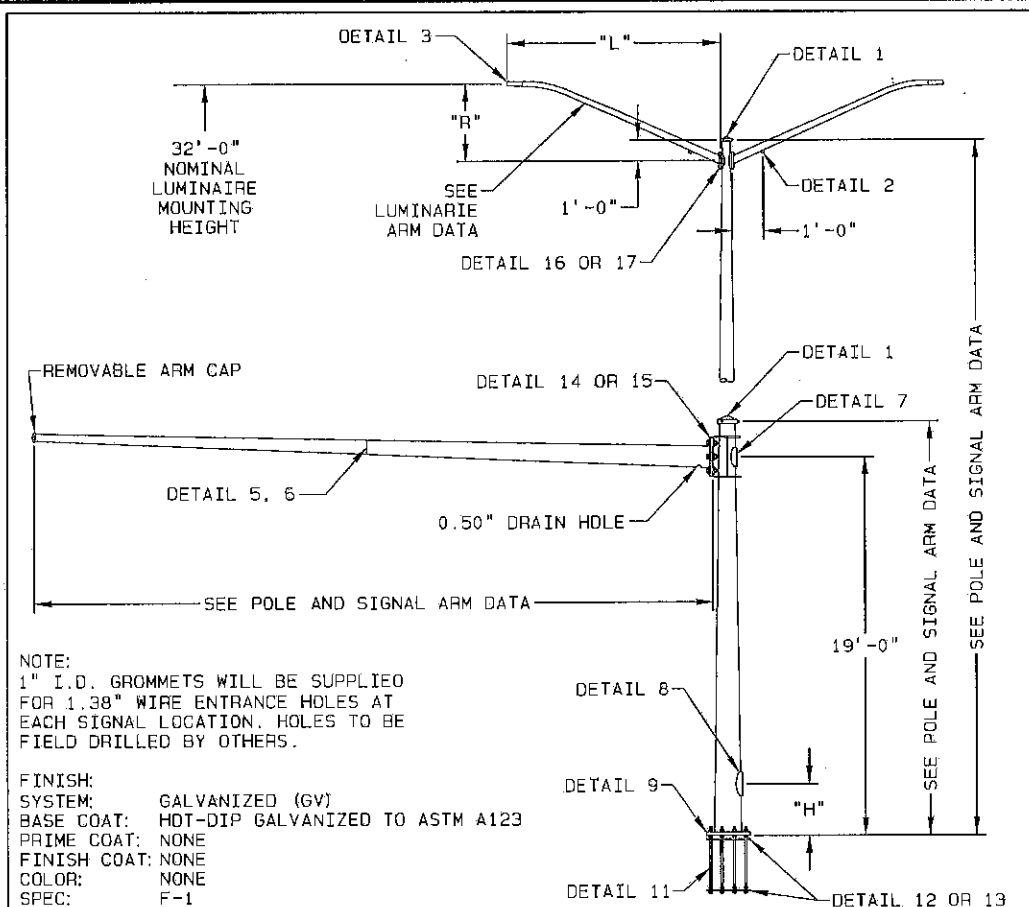

DEVICE	DESCRIPTION	PROJ. AREA (FT²)	WEIGHT (LBS)
(A)	12"-5 SEC. SIGNAL WITH BACKPLATES	13.33	105
(B)	12"-3 SEC. SIGNAL WITH BACKPLATES	8.67	60
(C)	18" X 108" STREET NAME SIGN	13.50	42
(D)	DUAL 12"-5 SEC. SIGNAL WITH BACKPLATES	26.66	210
(E)	POLE MOUNTED PED SIGNAL	3.23	28
(F)	24" X 30" SIGN	5	15
(G)	30" X 30" FOLDING STOP SIGN	6.25	19

MAXIMUM LOADING INFORMATION

THESE TRAFFIC SIGNAL SUPPORT STRUCTURES ARE DESIGNED IN ACCORDANCE WITH LOADING AND ALLOWABLE STRESS REQUIREMENTS OF 2013 AASHTO "STANDARDS SPECIFICATION FOR STRUCTURAL SUPPORTS FOR HIGHWAY SIGNS, LUMINAIRES AND TRAFFIC SIGNALS", SIXTH EDITION. WIND LOADS ARE BASED ON A BASIC WIND SPEED OF 90 MPH WITH A RECURRENCE INTERVAL OF 50 YEARS. FATIGUE CATEGORY 3 USED FOR STRUCTURE TYPES 9 & 10. FATIGUE CATEGORY 2 USED FOR STRUCTURE TYPES 12 & 13. FATIGUE LOADS ARE BASED ON THE REQUIREMENTS OF SECTION 11.7 AND THE FOLLOWING DESIGN LOADS:

NATURAL WIND GUSTS: THE YEARLY MEAN WIND SPEED FOR NATURAL WIND GUSTS WILL BE ASSUMED TO BE 11.2 MPH.

GALLOPING: STRUCTURES ARE DESIGNED TO RESIST PERIODIC GALLOPING FORCES.

TRUCK-INDUCED GUST: STRUCTURES ARE DESIGNED TO INCLUDE TRUCK-INDUCED GUSTS. (THE SPECIFIED AVERAGE TRUCK SPEED IS 45 MPH)

AASHTO 2013 SPECIFICATIONS

ALTHOUGH RARE, VIBRATIONS SEVERE ENOUGH TO CAUSE DAMAGE CAN OCCASIONALLY OCCUR IN STRUCTURES OF ALL TYPES. BECAUSE THEY ARE INFLUENCED BY MANY INTERACTING VARIABLES, VIBRATIONS ARE GENERALLY UNPREDICTABLE. THE USER'S MAINTENANCE PROGRAM SHOULD INCLUDE OBSERVATION FOR EXCESSIVE VIBRATION AND EXAMINATION FOR ANY STRUCTURAL DAMAGE OR BOLT LOOSENING. THE VALMONT WARRANTY SPECIFICALLY EXCLUDES FATIGUE FAILURE OR SIMILAR PHENOMENA RESULTING FROM INDUCED VIBRATION, HARMONIC OSCILLATION OR RESONANCE ASSOCIATED WITH MOVEMENT OF AIR CURRENTS AROUND THE PRODUCT.

VIBRATION DISCLAIMER

MATERIAL DATA

COMPONENT	ASTM DESIGNATION	MIN. YIELD (KSI)	COMPONENT	ASTM DESIGNATION	MIN. YIELD (KSI)
TAPERED TUBES	A595 GR. A DR A572	55	LUMINAIRE ARM ATTACH.	A36	36
POLE BASE	A572 GR.50	50	LUM. ARM CONN. BOLTS	A325*	
SIGNAL ARM ATTACHMENT	A36	36	ANCHOR BOLTS W/ SUPPLEMENTARY SPEC S4	F1554 GR.55	55
SIGNAL ARM CONN. BOLTS	A325*		ANCHOR BOLT TEMPLATE	A36	36
GALVANIZING STRUCTURE	A123				
GALVANIZING HARDWARE	HOT DIP ZINC				

* LUBRICATE IN THE FIELD IF NECESSARY

LUMINAIRE ARM DATA

ARM SPAN "L" (FT)	FIXED END DIA. (IN)	FREE END DIA. (IN)	GAUGE	RISE "R" (FT)
5.00	3.39	2.40	11	3.00
8.00	3.63	2.40	11	3.00
10.00	3.88	2.40	11	3.00
12.00	4.16	2.40	11	3.00
15.00	4.56	2.40	11	3.00

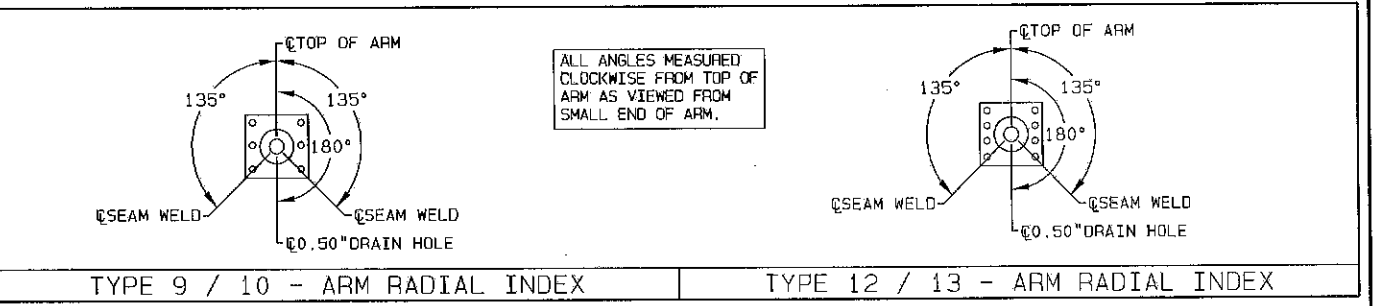

POLE AND SIGNAL ARM DATA

STRUCTURE TYPE	POLE TUBE			POLE BASE				ANCHOR BOLT DATA					SIGNAL ARM TUBE					
	BASE DIA. (IN)	TOP DIA. (IN)	LENGTH (FT)	GAUGE OR THK. (IN)	SQUARE "S" (IN)	BOLT CIRCLE "Y" (IN)	THK. "M" (IN)	CENTER HOLE "P" (IN)	BOLT HOLE "Z" (IN)	DIA. "K" (IN)	LENGTH "J" (IN)	THREAD LENGTH "U1" (IN)	THREAD LENGTH "U2" (IN)	ANCHOR BOLT QTY.	FIXED END DIA. (IN)	FREE END DIA. (IN)	GAUGE OR THK (IN)	SPAN (FT)
TYPE 9	11.50	8.56	21.00	7	19.00	15.00	2.00	10.14	1.75	1.50	52.00	10.00	5.50	6	8.00	5.90	7	15.00
															8.00	5.20	7	20.00
															9.00	5.50	7	25.00
															9.00	4.80	7	30.00
TYPE 10	11.50	7.30	30.00	7	19.00	15.00	2.00	10.14	1.75	1.50	52.00	10.00	5.50	6	8.00	5.90	7	15.00
															8.00	5.20	7	20.00
															9.00	5.50	7	25.00
															9.00	4.80	7	30.00
TYPE 12	19.20	16.26	21.00	0.313	29.00	24.00	2.00	12.00	2.00	1.75	86.00	11.00	5.50	6	14.50	9.60	0.250	35.00
															15.50	9.90	0.250	40.00
															17.00	10.70	0.250	45.00
															16.00	9.38	DET.5	50.00
															16.25	8.93	DET.5	55.00
															14.50	9.60	0.250	35.00
TYPE 13	19.20	15.00	30.00	0.313	29.00	24.00	2.00	12.00	2.00	1.75	86.00	11.00	5.50	6	14.50	9.60	0.250	35.00
															15.50	9.90	0.250	40.00
															17.00	10.70	0.250	45.00
															16.00	9.38	DET.5	50.00
															16.25	8.93	DET.5	55.00
															14.50	9.60	0.250	35.00

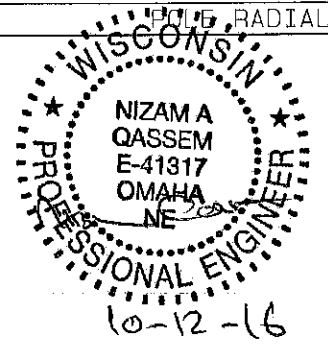
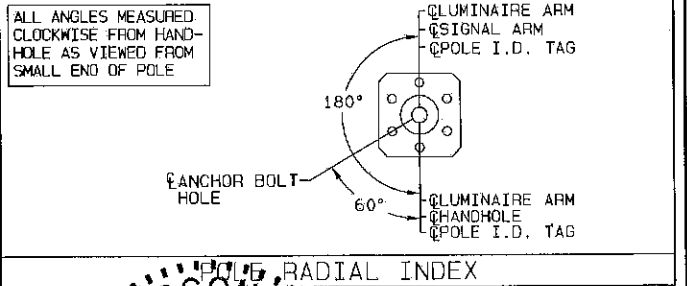

REV	DATE	DESCRIPTION
E	NKL 10/12/16	REVISED LUMINAIRE/MAST ARM DATA
D	NKL 12/16/15	REVISED ANCHOR BOLT DATA
C	NKL 01/21/15	ADDED THREAD LENGTH TO BOLT
B	NKL 12/17/14	POLE SIZES TYPE 12/13 / ADD PAGE 3 DETAIL
A	NKL 03/11/14	REVISED TYPE 12/13 SIZES
	AC19 11/27/13	

TITTLE
WISCONSIN DEPARTMENT OF TRANSPORTATION
 TYPES 9, 10, 12, & 13 TRAFFIC SIGNAL STRUCTURES
 AASHTO 2013

VALMONT INDUSTRIES, INC. RESERVES THE RIGHT TO INSTALL VARIOUS, ENGINEER APPROVED, MATERIAL HANGING ACCOMMODATIONS TO FACILITATE THE MANUFACTURING PROCESS.



PAGE NUMBER: 1 OF 3	REV
DRAWING NUMBER	DB01072

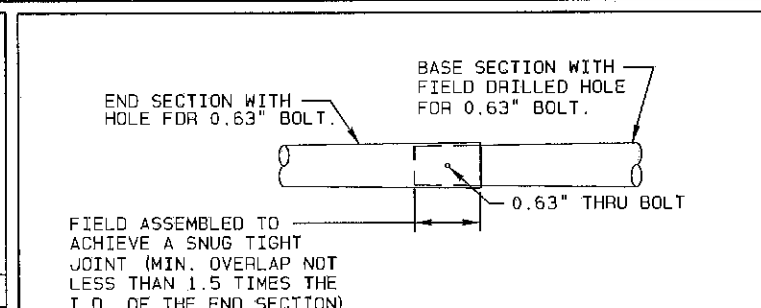
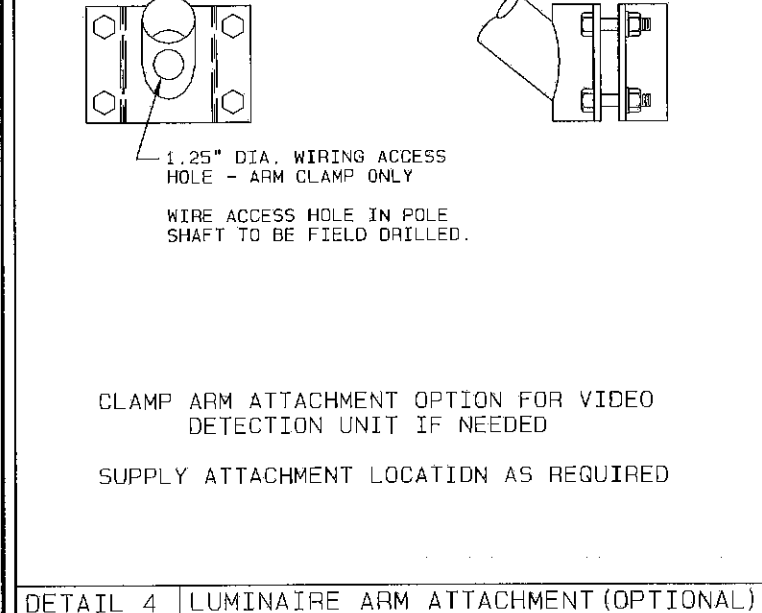
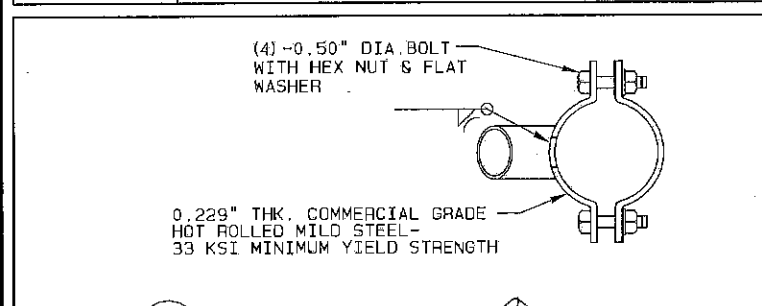
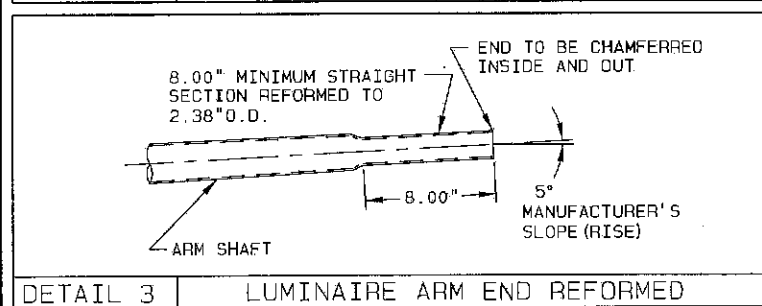
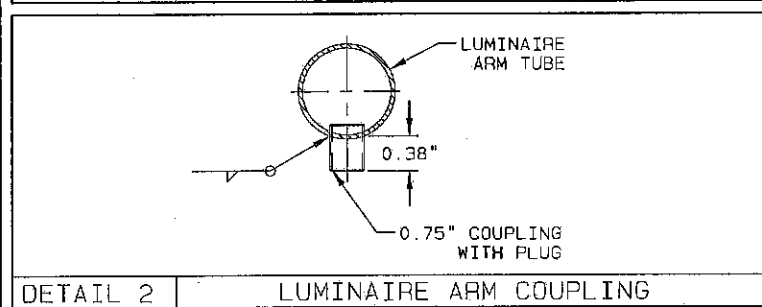
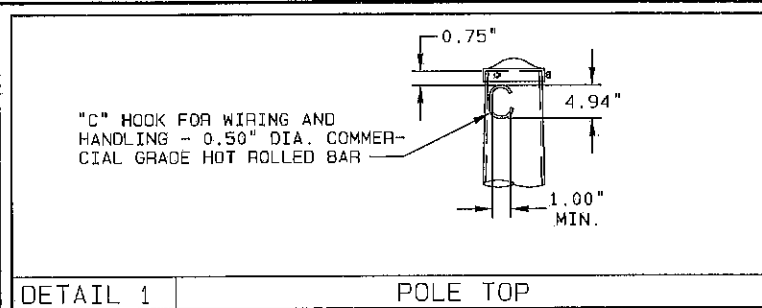

SPAN	BASE SECTION		END SECTION	
	LENGTH	WALL	BASE OD	LENGTH
50.00'	15.00'	0.500"	14.68"	37.90'
55.00'	15.00'	0.500"	14.94"	42.93'

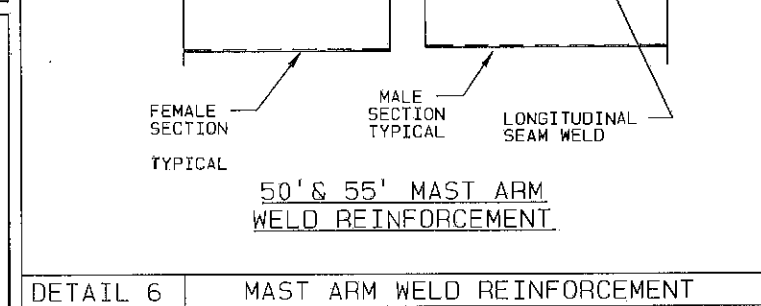
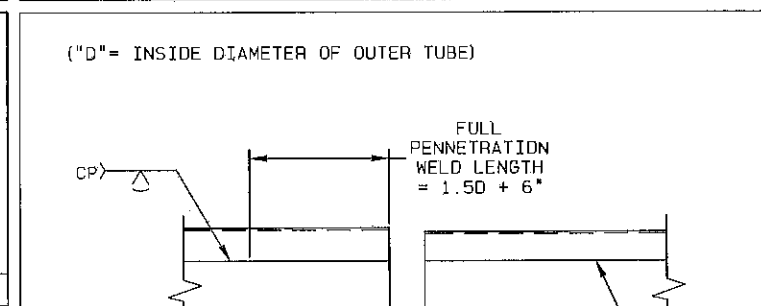

10-12-16

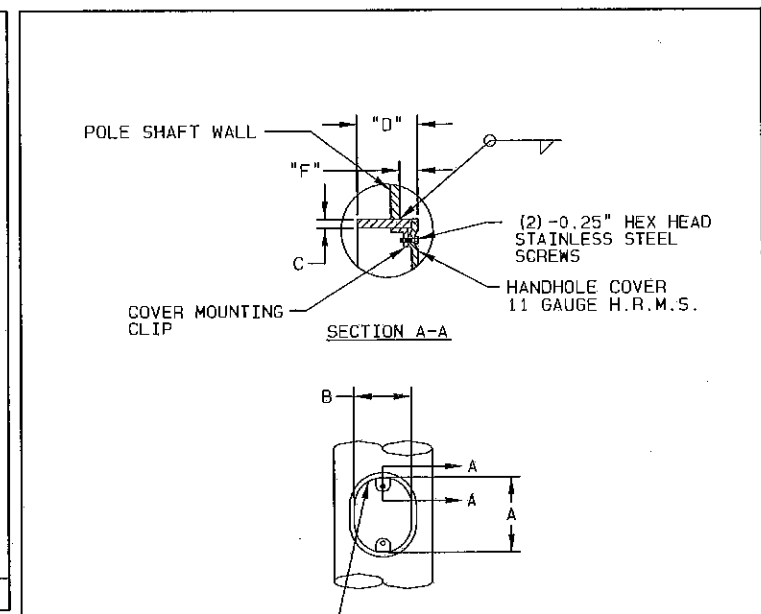

POLE TYPE	"A" I.D. (IN)	"B" I.D. (IN)	"C" THK (IN)	"D" DEPTH (IN)	"E" RADIUS (IN)	"F" PROJ. (FT)
9	5.50	3.50	0.375	2.00	1.50	0.50
10	5.50	3.50	0.375	2.00	1.50	0.50
12	6.56	4.50	0.500	2.00	2.00	0.50
13	6.56	4.50	0.500	2.00	2.00	0.50

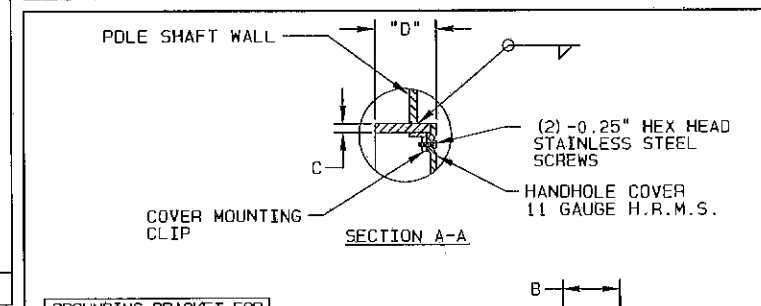

POLE TYPE	"A" I.D. (IN)	"B" I.D. (IN)	"C" THK (IN)	"D" DEPTH (IN)	"E" RADIUS (IN)	"F" PROJ. (IN)	"H" MTG. HEIGHT (FT)
9	12.00	4.50	0.500	3.00	2.00	0.50	1.50
10	12.00	4.50	0.500	3.00	2.00	0.50	1.50
12	14.00	7.50	0.875	3.25	3.00	0.50	2.23
13	14.00	7.50	0.875	3.25	3.00	0.50	2.23

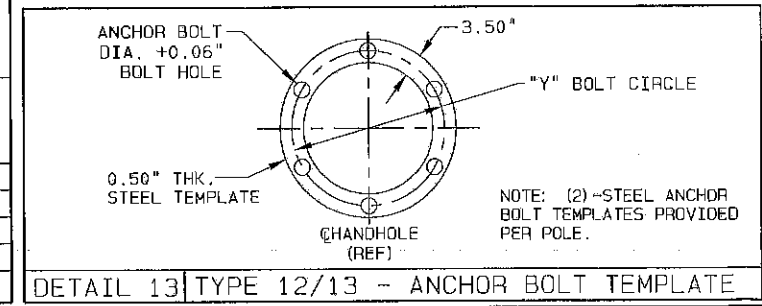
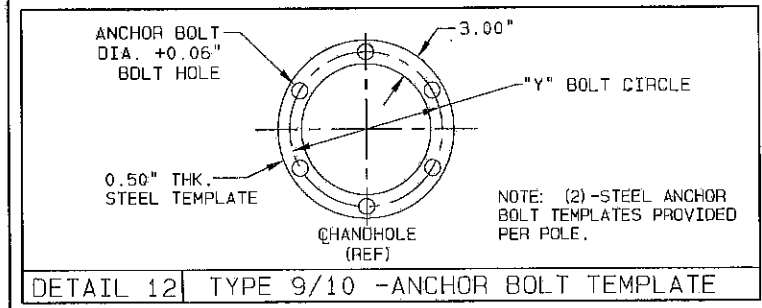
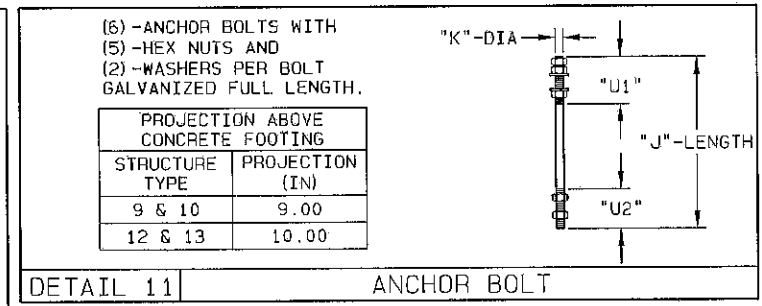
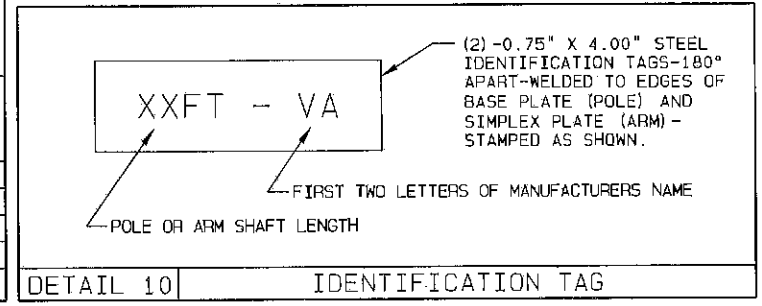
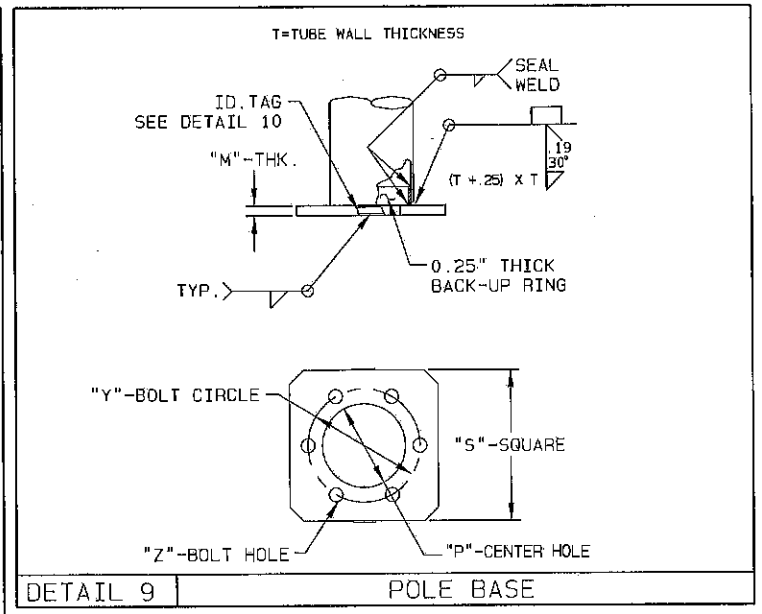

TITLE
 WISCONSIN DEPARTMENT OF TRANSPORTATION
 TYPE 9, 10, 12, & 13 TRAFFIC SIGNAL STRUCTURES
 AASHTO 2013

VALMONT INDUSTRIES, INC. RESERVES THE RIGHT TO INSTALL VARIOUS, ENGINEER APPROVED, MATERIAL HANGING ACCOMMODATIONS TO FACILITATE THE MANUFACTURING PROCESS.

Valley, NE 68064
 (402) 359-2201

PAGE NUMBER: 2 OF 3
 DRAWING NUMBER: DB01072
 REV: E

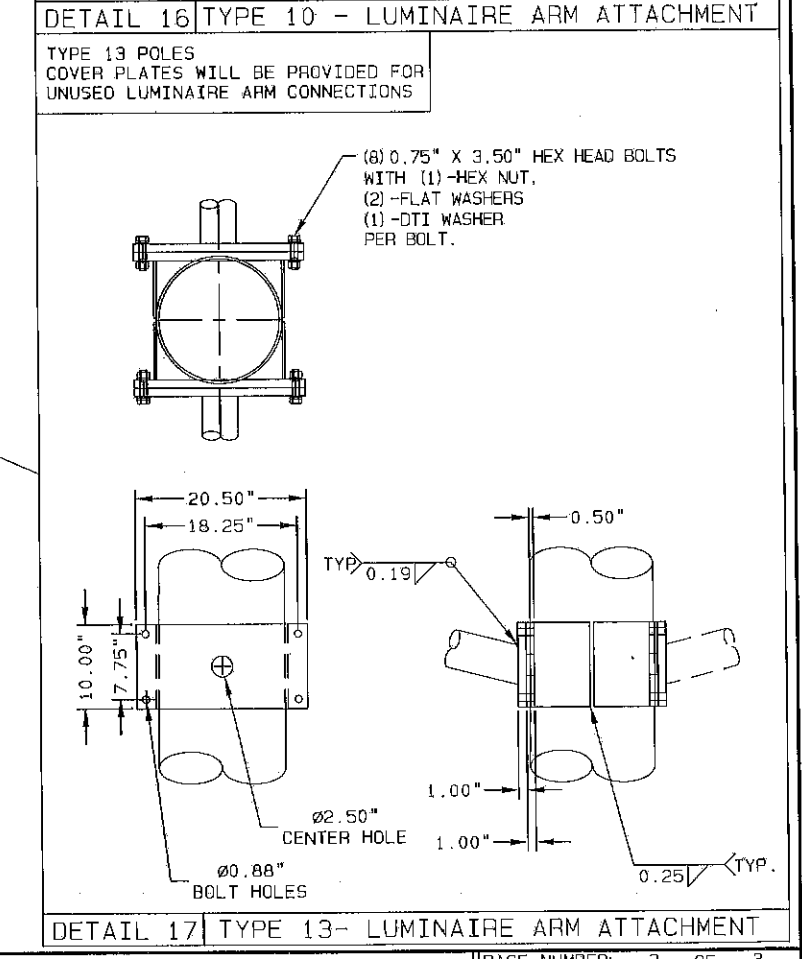
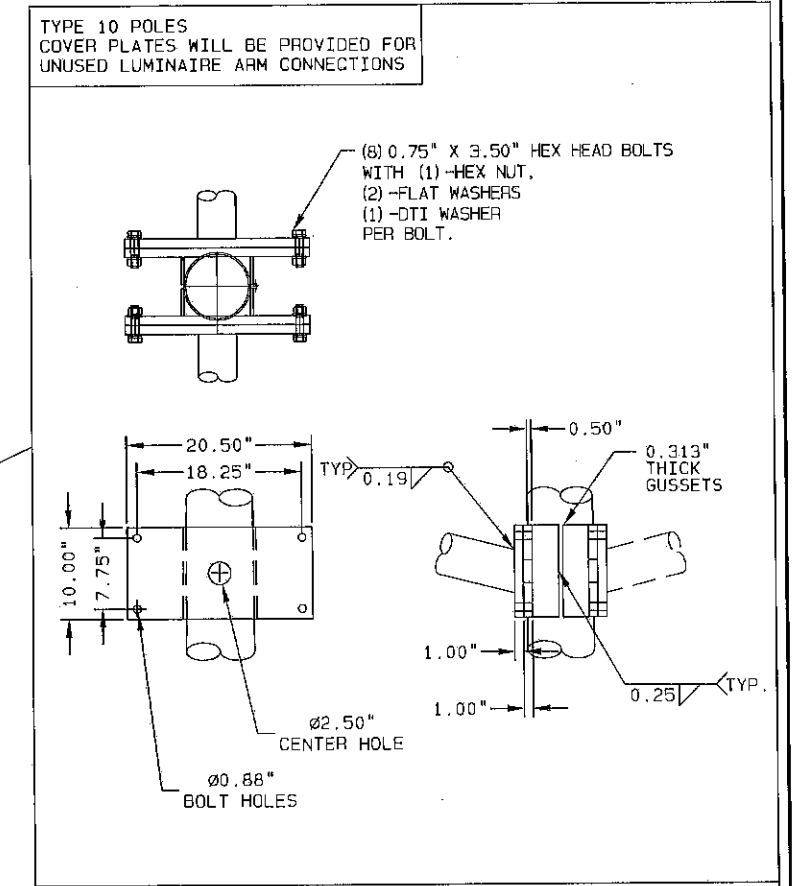
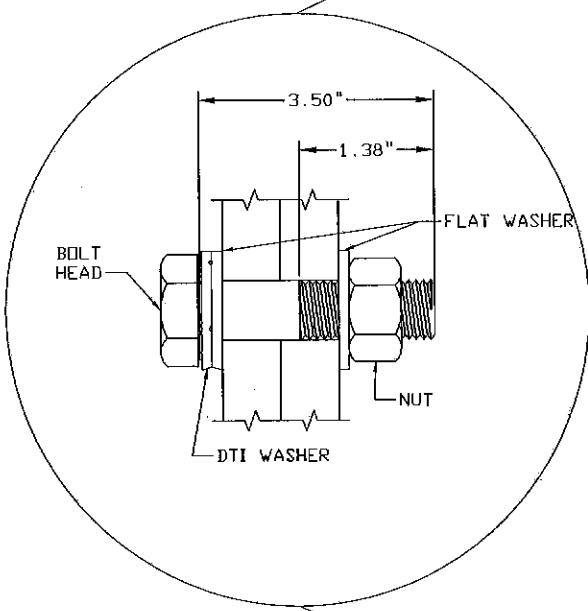
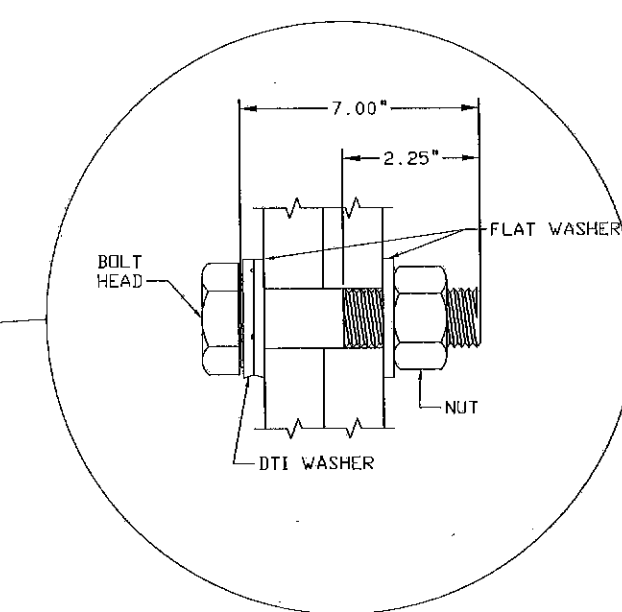
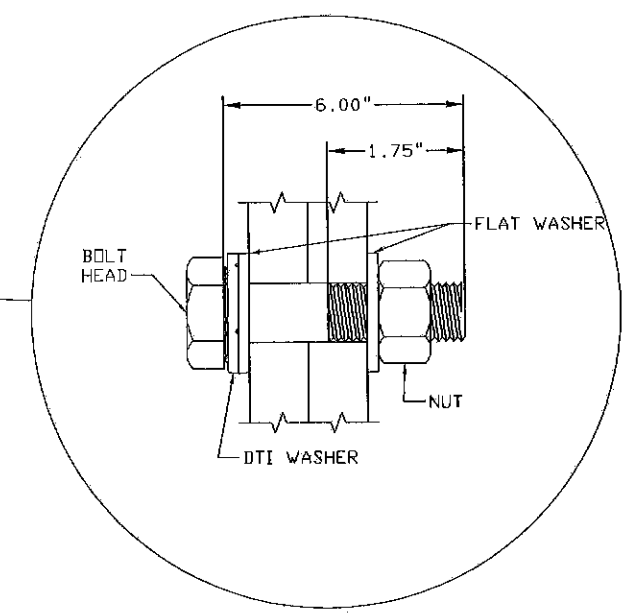
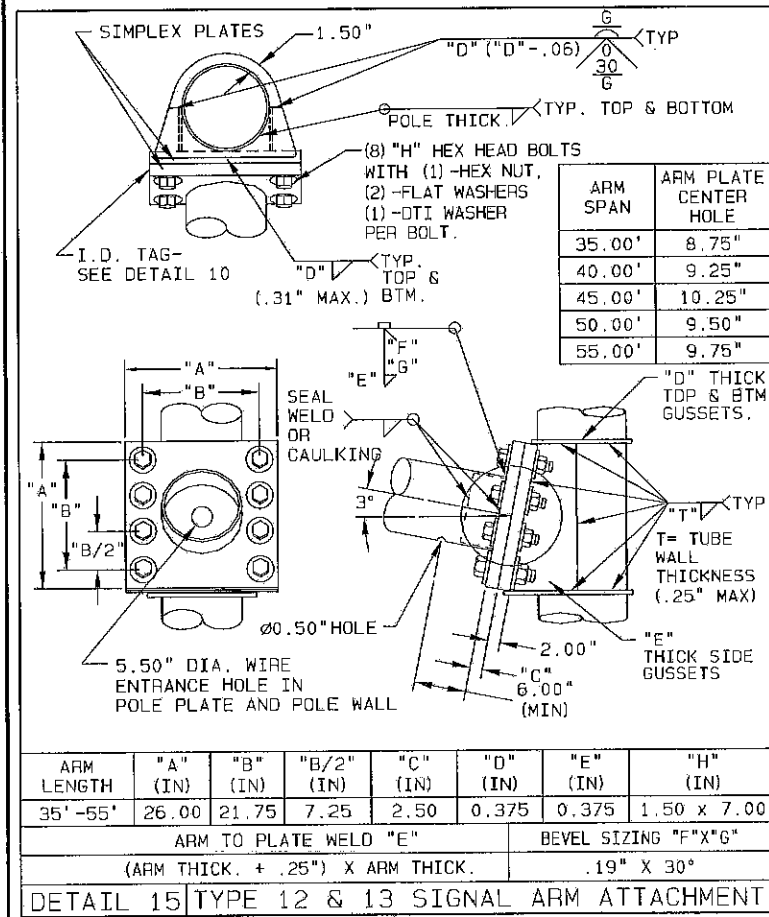
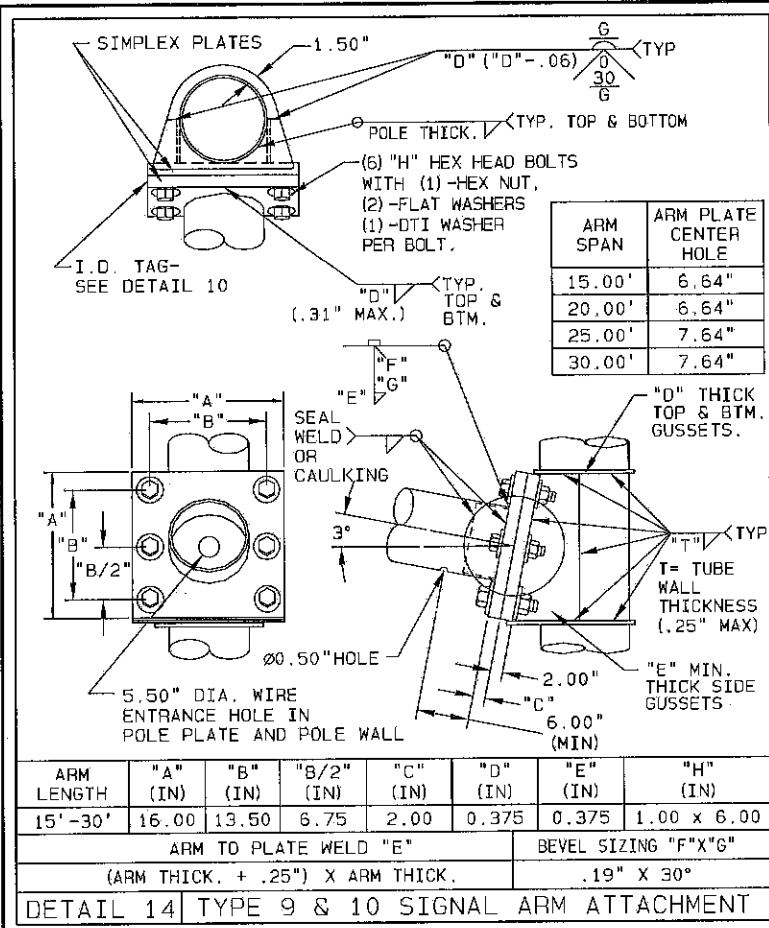

WISCONSIN
NIZAM A QASSEM
E-41317
OMAHA
PROFESSIONAL ENGINEER
10-12-16