

2020

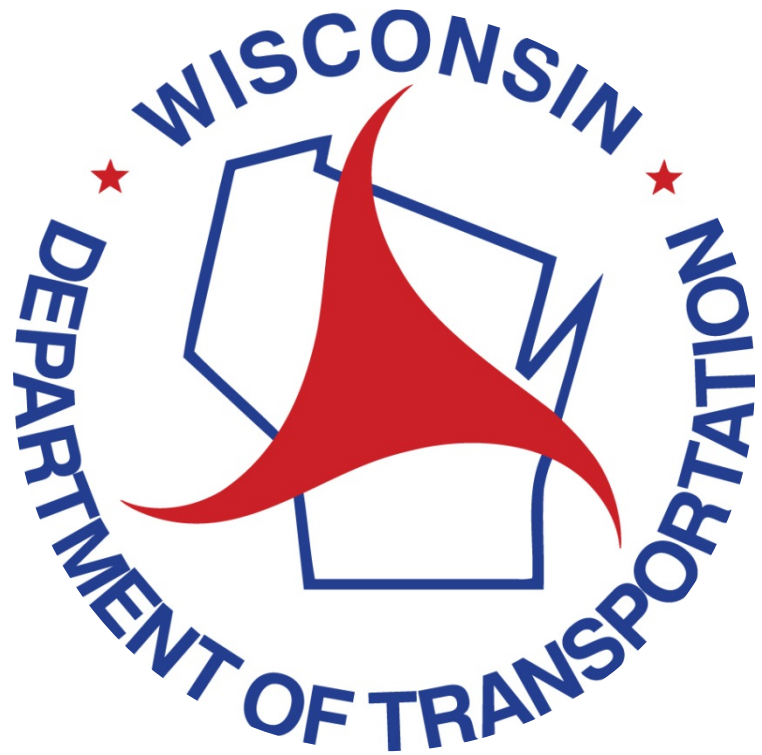

STRUCTURE INSPECTION FIELD MANUAL

Wisconsin Department of Transportation

Table of Contents

	Element List – Bridge Structures	3
Chapter 1.	The Wisconsin Department of Transportation’s Field Manual for Structure Element Inspection	9
A.	How to use this manual	9
B.	Background.....	10
Chapter 2.	Field	11
A.	Inspection Planning and Preparation.....	12
B.	Performing the Inspection	13
C.	Documenting the Inspection.....	14
D.	General Guidance on Element Level Inspection.....	15
Chapter 3.	Condition State Descriptions – Bridge Structures	17
A.	Steel	19
B.	Reinforced Concrete	29
C.	Prestressed Concrete	43
D.	Timber	55
E.	Masonry	67
F.	Other Materials	75
G.	Bearings	79
H.	Joints	87
I.	Steel Protective Coatings.....	93
J.	Wearing Surfaces	97
K.	Reinforcing Steel Protective Systems.....	103
L.	Concrete Protective Coating	105

	M.	Strengthening/Repair Systems.....	107
Chapter 4.		Assessments.....	111
Chapter 5.		National Bridge Elements.....	126
	A.	Decks/Slabs.....	127
	B.	Superstructure.....	130
	C.	Substructure.....	142
	D.	Bearings.....	151
	E.	Bridge Rail.....	153
Chapter 6.		Bridge Management Elements/Agency Defined Elements.....	156
	A.	Joints.....	157
	B.	Structural Approach Slabs.....	158
	C.	Protective/Strengthening Systems.....	159
	D.	Wearing Surfaces.....	161
Chapter 7.		Ancillary Structures.....	163
		Sign/Signal/HML Elements.....	164
		Wall Elements.....	173
		Ancillary Assessments.....	193
Chapter 8.		Critical Findings Procedure.....	201
Chapter 9.		NBI Rating System.....	202
Chapter 10.		Field Abbreviations.....	213

Element List

Element List – Bridge Structures

(ADE: Agency Defined Element NBE: National Bridge Element BME: Bridge Management Element)

Decks/Slabs				
Element Number	Element	Units	Type	Page Number
12	Reinforced Concrete Deck	SF	NBE	29
13	Prestressed Concrete Deck	SF	NBE	43
15	Prestressed Concrete Top Flange	SF	NBE	43
16	Reinforced Concrete Top Flange	SF	NBE	29
28	Steel Deck with Open Grid	SF	NBE	19
29	Steel Deck with Concrete Filled Grid	SF	NBE	19
30	Steel Deck with Corrugated/Orthotropic/Etc.	SF	NBE	19
31	Timber Deck	SF	NBE	55
38	Reinforced Concrete Slab	SF	NBE	29
8039	Prestressed Concrete Slab	SF	NBE	43
54	Timber Slab	SF	NBE	55
60	Other Material Deck	SF	NBE	75
65	Other Material Slab	SF	NBE	75
Superstructure				
102	Steel Closed Web/Box Girder	LF	NBE	19
104	Prestressed Concrete Closed Web/Box Girder	LF	NBE	43
105	Reinforced Concrete Closed Web/Box Girder	LF	NBE	29
106	Other Material Closed Web/Box Girder	LF	NBE	75
107	Steel Open Girder/Beam	LF	NBE	19
109	Prestressed Concrete Open Girder/Beam	LF	NBE	43
110	Reinforced Concrete Open Girder/Beam	LF	NBE	29
111	Timber Open Girder/Beam	LF	NBE	55
112	Other Material Open Girder/Beam	LF	NBE	75
113	Steel Stringer	LF	NBE	19
115	Prestressed Concrete Stringer	LF	NBE	43

Superstructure					
Element Number	Element	Units	Type	Page Number	
116	Reinforced Concrete Stringer	LF	NBE	29	
117	Timber Stringer	LF	NBE	55	
118	Other Material Stringer	LF	NBE	75	
120	Steel Truss	LF	NBE	19	
135	Timber Truss	LF	NBE	55	
136	Other Material Truss	LF	NBE	75	
141	Steel Arch	LF	NBE	19	
142	Other Material Arch	LF	NBE	75	
143	Prestressed Concrete Arch	LF	NBE	43	
144	Reinforced Concrete Arch	LF	NBE	29	
145	Masonry Arch	LF	NBE	67	
146	Timber Arch	LF	NBE	55	
147	Steel Main Cables	LF	NBE	19	
148	Steel Secondary Cables	EA	NBE	19	
152	Steel Floor Beam	LF	NBE	19	
154	Prestressed Concrete Floor Beam	LF	NBE	43	
155	Reinforced Concrete Floor Beam	LF	NBE	29	
156	Timber Floor Beam	LF	NBE	55	
157	Other Material Floor Beam	LF	NBE	75	
161	Steel Pin, Pin & Hanger Assembly or both	EA	NBE	19	
162	Steel Gusset Plate	EA	NBE	19	
8165	Steel Tension Rods/Post-Tensioned Cables	EA	ADE	19	
8166	Timber Spreader Beam	LF	ADE	55	
8170	Other Primary Structural Members	Steel	LF	ADE	19
		Reinforced Concrete	LF	ADE	29
		Prestressed Concrete	LF	ADE	43
		Timber	LF	ADE	55
		Masonry	LF	ADE	67

Element List

Substructure				
Element Number	Element	Units	Type	Page Number
202	Steel Column	EA	NBE	19
203	Other Material Column	EA	NBE	75
204	Prestressed Concrete Column	EA	NBE	43
205	Reinforced Concrete Column	EA	NBE	29
206	Timber Column	EA	NBE	55
207	Steel Tower	LF	NBE	19
208	Timber Trestle	LF	NBE	55
210	Reinforced Concrete Pier Wall	LF	NBE	29
211	Other Material Pier Wall	LF	NBE	75
212	Timber Pier Wall	LF	NBE	55
213	Masonry Pier Wall	LF	NBE	67
215	Reinforced Concrete Abutment	LF	NBE	29
216	Timber Abutment	LF	NBE	55
217	Masonry Abutment	LF	NBE	67
218	Other Material Abutments	LF	NBE	75
219	Steel Abutment	LF	NBE	19
220	Reinforced Concrete Pile Cap/Footing	LF	NBE	29
225	Steel Pile	EA	NBE	19
226	Prestressed Concrete Pile	EA	NBE	43
227	Reinforced Concrete Pile	EA	NBE	29
228	Timber Pile	EA	NBE	55
229	Other Material Pile	EA	NBE	75
231	Steel Pier Cap	LF	NBE	19
233	Prestressed Concrete Pier Cap	LF	NBE	43
234	Reinforced Concrete Pier Cap	LF	NBE	29
235	Timber Pier Cap	LF	NBE	55
236	Other Material Pier Cap	LF	NBE	75

Substructure					
Element Number	Element	Units	Type	Page Number	
8400	Integral Wingwall	Steel	EA	ADE	19
		Reinforced Concrete	EA	ADE	29
		Prestressed Concrete	EA	ADE	43
		Timber	EA	ADE	55
		Masonry	EA	ADE	67
		Other Materials	EA	ADE	75
Culverts					
240	Steel Culvert	LF	NBE	19	
241	Reinforced Concrete Culvert	LF	NBE	29	
242	Timber Culvert	LF	NBE	55	
243	Other Material Culvert	LF	NBE	75	
244	Masonry Culvert	LF	NBE	67	
245	Prestressed Concrete Culvert	LF	NBE	43	
Bearings					
310	Elastomeric Bearing	EA	NBE	79	
311	Movable Bearing	EA	NBE	79	
313	Fixed Bearing	EA	NBE	79	
314	Pot Bearing	EA	NBE	79	
315	Disc Bearing	EA	NBE	79	
316	Other Bearing	EA	NBE	79	
Joints					
300	Strip Seal Expansion Joint	LF	BME	87	
301	Pourable Joint Seal	LF	BME	87	
302	Compression Joint Seal	LF	BME	87	
303	Modular Joint	LF	BME	87	
304	Open Expansion Joint	LF	BME	87	
305	Assembly Joint without Seal	LF	BME	87	
306	Other Joint	LF	BME	87	

Element List

Bridge Approach/Roadway Elements				
Element Number	Element	Units	Type	Page Number
320	Prestressed Concrete Structural Approach Slab	SF	BME	43
321	Reinforced Concrete Structural Approach Slab	SF	BME	29
Bridge Rail				
330	Metal Bridge Railing	LF	NBE	19
331	Reinforced Concrete Bridge Railing	LF	NBE	29
332	Timber Bridge Railing	LF	NBE	55
333	Other Material Bridge Railing	LF	NBE	75
334	Masonry Bridge Railing	LF	NBE	67
Wearing Surfaces				
510	Wearing Surfaces (Other)	SF	BME	97
8000	Wearing Surface (Bare)	SF	ADE	97
8511	AC Overlay	SF	ADE	97
8512	AC Overlay & Membrane	SF	ADE	97
8513	Thin Polymer Overlay	SF	ADE	97
8514	Concrete Overlay	SF	ADE	97
8515	Polyester Concrete Overlay	SF	ADE	97
Steel Protective Coatings				
515	Steel Protective Coating (Other)	SF	BME	93
8516	Painted Steel	SF	ADE	93
8517	Weathering Steel	SF	ADE	93
8518	Galvanization	SF	ADE	93
8519	Duplex Systems	SF	ADE	93
Reinforcing Steel Protective System				
520	Concrete Reinforcing Steel Protective System (Other)	SF	BME	103
8522	Coated Reinforcing	SF	ADE	103
8523	Stainless Steel Reinforcing	SF	ADE	103
8524	Non-Metallic Reinforcing	SF	ADE	103
Concrete Protective Coatings				
521	Concrete Protective Coating	SF	BME	105

Strengthening/Repair Systems

8800	FRP	EA	ADE	107
8801	Jacketing	EA	ADE	107
8802	Culvert Liner	LF	ADE	107
8803	External Post Tensioning	EA	ADE	107

Chapter 1. The Wisconsin Department of Transportation’s Field Manual for Structure Element Inspection

This Manual is designed to aid Structure Inspectors in performing accurate and consistent structure inspections and was developed for convenient use in the field. Please read this Manual carefully. For additional details, the user should consult the Structure Inspection Manual for more complete details on the inspection program. Refer to the procedures in the Foreword of the Structure Inspection Manual to notify the author of any future comments or revisions for this Manual.

This Manual contains information on Field and Element Level Inspections; Condition state descriptions; National Bridge Elements (NBE), Bridge Management Elements (BME), and Agency Defined Elements (ADE); Assessments; Ancillary Structures, and other useful information. Inspectors should use this manual to record all deficiencies, as well as any comments about the bridge inspection procedure, problems encountered, etc. on the Inspection Report form and appropriate supplemental forms (as needed).

A. How to use this manual

Structure inspection documentation using this manual consists of defining the elements (parts of the structure), identifying the material type of each element, determining their total quantities, evaluating their condition based on the material and structural defects, and properly documenting the findings. The condition of each element is determined by performing a field inspection, assigning condition states that correlate to the severity of the defects, and recording the quantities of the defects in each element. Condition States for each element are defined within this manual. The condition assessment is complete when the appropriate portion of the total quantity is allocated over the defined condition states.

Due to the nature of the Element Level inspection, inspectors will be coding the condition states of various defects for elements. The Department will only code the worst case scenario defects for each element per unit of measure. This will be representative of the overall element condition state for that unit of measure. Once all of the defects are ascertained, the inspector will then allocate the appropriate condition states for the overall element based on the condition states of the various defects. Since only worst case scenario defects will be recorded in the condition state table, it will be essential that the inspector take thorough notes to ascertain the location of all defects located throughout the element.

This Manual attempts to cover the vast majority of all elements found on structures in Wisconsin. An inspector may find materials or elements that are not defined during the course of their inspection. In these cases, the inspector should use judgment to select the closest element match. In a similar manner, there may be cases when the specific condition observed in the field is not defined in this manual. In these cases, the inspector should use the general description of the condition states for material defects to determine the appropriate condition states.

B. Background

The Wisconsin Department of Transportation's Structure Inspection Field Manual builds on the element level condition assessment methods developed in the AASHTO Manual for Element Inspection, 1st Edition, 2013. Improvements have been made to fully capture the condition of the elements by reconfiguring the element language within the defined condition states. The overall condition of an element can be utilized in this aggregate form, or broken down into specific defects present as desired by the agency for Structure Management System use.

This manual provides a comprehensive set of elements and assessments that is designed to be flexible in nature to satisfy the needs of all agencies. The complete set of elements capture the information necessary for an agency to manage all aspects of the inventory.

The element set from the AASHTO Manual for Bridge Element Inspection, 1st Edition, 2013, is presented within and includes three element types; National Bridge Elements (NBE), Bridge Management Elements (BME), and Agency Developed Elements (ADE). All elements, whether they are NBE, BME, or ADE utilize four (4) condition states.

Condition State 1 = Good

Condition State 2 = Fair

Condition State 3 = Poor

Condition State 4 = Severe

The level of detail of the defects is typically eliminated for Condition State 4, as this condition state is reserved for severe conditions that are beyond those specific defects defined in Condition States 1 through 3 and may often have load capacity implications. However, some specific guidelines are provided for Condition State 4 in this Manual to promote consistency.

Chapter 2. Field

The following chapter is to be used as a field guide for the inspector at the bridge site. Any information in this chapter can be expanded upon in the WisDOT Structure Inspection Manual and the AASHTO Manual for Bridge Element Inspection.

A. Inspection Planning and Preparation

- 1) Identify structure elements and assessments
 - i. Review as-built drawings and identify each element. If forms exist, review and verify the element data (design, material, and quantity) matches the as-builts.
 - ii. Calculate quantities for each element and compute or verify the total quantity for the structure.
- 2) Prepare field forms and sketches
 - i. Prepare forms in HSI and sketches for documenting condition states in the field. Forms should accommodate all defect types as applicable and provide sufficient room for adding inspection notes.
 - ii. Verify the bridge elements (number and name) on the HSI form and the associated total quantities. Leave room for additional elements that may be discovered in the field. For existing forms and sketches, review content and update as needed.
- 3) Develop inspection plan
 - i. The inspection plan should include procedures for collecting data. Consider inspection sequence and access when developing the plan. Elements are generally evaluated in 3 dimensions and may have overlapping defects. The defects will be assessed on type and severity. All defects must be considered in the determination of controlling condition states.
 - ii. Review and update procedures outlined in the bridge inspection report as necessary to identify changes to the bridge or new requirements.
 - iii. Record bridge specific inspection plans and procedures on the inspection form and in HSI.

B. Performing the Inspection

- 1) Record defects
 - i. Record type, severity, and extent of defects on the sketches and forms provided using the standard terminology and descriptors.
 - ii. Track defects throughout the element and identify overlapping defects.
 - iii. Identify worst case scenario defects for a given element (within a unit of measure) and record this on your inspection form.
 - iv. Take thorough notes to identify location of worst case scenario defects, as well as structural defects. It will be necessary for the inspector to document exact location, orientation, length, and size of each defect. This will be essential for repeatability during future inspections. Document CS 3 and CS 4 defects with photos.
 - v. If corrosion or debris build-up prevents visual inspection, then the inspector must clean accordingly to properly ascertain the condition of the element.
 - vi. Where an element is not clearly visible to the inspector, an Interim inspection may need to be scheduled so that proper equipment, cleaning, access, traffic control, etc... can be mobilized to adequately inspect, assess, and properly document any defect's condition state.
- 2) Identify condition states and quantities
 - i. Identify the condition states and the associated quantities for each defect.
 - ii. Based on defect condition states, apply the applicable condition states to the element.
 - iii. If condition warrants analysis, indicate in the notes why it should be done; check the re-rate box; and document specific location in span and on element, through the use of measurements, pictures, and/or sketches. Measurements are particularly important for performing load ratings.
- 3) Conduct Quality Control (QC)
 - i. The Team Leader is responsible for adhering to their internal quality control procedures.

C. Documenting the Inspection

- 1) Complete Agency forms
 - i. Use standard forms (Highway Structures Information System - HSI) to enter element data and inspection notes.
- 2) Update forms and photographs
 - i. Based on field work, update necessary DT forms and sketches as needed. Forms to be uploaded in HSI.
 - ii. Photographs and/or sketches **are required** for elements in either CS 3 or CS 4 for each inspection. For an element/defect combination in CS 3, a minimum of one representative photo/sketch is required; inspectors should use judgement when considering the need for additional photos to adequately document the condition. Photos **are required** at each location with a CS 4 quantity.
- 3) Make recommendations
 - i. The inspector should place applicable maintenance recommendations within the inspection report to correct deficient elements and to arrest further deterioration of the element.
 - ii. Inspector shall assign a maintenance priority for each maintenance item identified. The priority can be set in HSI to high, medium, and low.
 - i. High Priority - To be completed within 30 days of the finding.
 - ii. Medium Priority - To be completed within a year of the finding.
 - iii. Low Priority - To be completed before the next inspection.
 - iii. Inspector shall ascertain what maintenance actions were performed on the structure since the last inspection and make sure those actions are documented in HSI accordingly.
- 4) Recommendation Follow-Up
 - i. It is the responsibility of the Program Manager, or the Program Managers' delegate to ensure short term repair recommendations are completed within the timeframe described in the maintenance item (e.g. if a repair is recommended to be completed within six months, it should be verified after six months after inspection to ensure repair has been made).

D. General Guidance on Element Level Inspection

- 1) Structural defects include Settlement and Scour and occur only at substructures (abutments and piers) elements only. Structural defects do not count toward the total element quantity and associated condition states. Agency Defined Defects (ADD) do not count toward the overall National Bridge Elements (NBE) quantity, but do apply to the Bridge Management Elements (BME) and Agency Defined Elements (ADE). ADD's include defects such as wingwall movement, wingwall deterioration, discoloration, chloride concentration among others.
- 2) Where multiple condition states exist within a unit of measure, the most predominant defect in severity AND extent controls; i.e., the condition state that gets reported within that unit of measure. The quantity of the more severe condition state, accounting for overlapping defects, is computed and reported first followed by successively less severe condition states. The sum of all of the reported condition states must equal the total quantity of the element.
 - i. Example: a deck has 25sf on the bottom surface in Condition State 2 for cracking in the SE corner of a bridge and 15sf on the bottom surface of Condition State 3 for spalling in the SE corner of the bridge. 15sf would be recorded in Condition State 3 for spalling and 10 SF would be recorded in Condition State 2 under the cracking defect since they overlap each other. The 15sf of Condition State 3 found on the bottom surface would control over the overlapping Condition State 2.
- 3) Elements are evaluated as one unit of measurement; linear feet (LF), square feet (SF), and each (EA) at a time. All defects contained within that unit are recorded for that unit. Each unit of measure for each element is evaluated for all defects associated with that element with the worst case noted and recorded.
- 4) When calculating LF, the quantity should include the sum of all the lengths of each section.
 - i. Example: Bridge girders are 100 feet long and there are five girders; Total quantity will be 500 LF.

- 5) Quantifying defects in elements using LF will be the size of the defect rounding up to the nearest whole foot. For units of LF and EA, the height/depth of the defect does not factor into the quantity calculation, but may affect the condition state. For units of SF, any defect within 1 SF will be recorded as 1 SF regardless of the extent of that defect.
- i. Example: A defect 0.9 foot long by 0.1 foot high or a defect 0.9 foot long by full height of girder will both be recorded as 1 LF of defect.
 - ii. Example: A 2.8 foot long defect will be recorded as 3 LF, while a 3.2 foot long defect will be recorded as 4 LF.
- 6) The condition states of the element are based on the descriptions provided. In general, the four condition states are defined as follows:

Condition State 1 (Good) – Any deficiency is minor and has no impact on the performance of the element. Any deficiencies that exist would be expected for the material and bridge construction used.

Condition State 2 (Fair) – The deficiency has advanced but with no impact on the performance of the element. Under continued exposure, the element will degrade further.

Condition State 3 (Poor) – The deficiency has advanced further and additional deterioration will ultimately impact the strength and/or serviceability of the element

Condition State 4 (Severe) – The deficiency has advanced to the point where the strength or serviceability of the element may be affected and a structural review is necessary to determine the effect on strength or serviceability of the element or the bridge. The Team Leader shall elevate this deficiency to the attention of the Owner and Program Manager to determine if any action is required.

E. Structural Review of CS4 (Severe) Primary Structural Members

Structural reviews are necessary when the condition of the member reaches a severe state and the structural capacity of the bridge may be compromised. Structural reviews may include a review of the field inspection notes and photographs, review of as-built plans, and/or an analysis

Chapter 3 – Condition State Descriptions – Bridge Structures

as deemed necessary by the Engineer. More information can be found on the Wisconsin DOT Inspection Website. In general, structural reviews:

- Must be performed by a Wisconsin Professional Engineer
- Must be completed no later than 60 days after the inspection.
- Must be documented in the Highway Structures Information System

Chapter 3. Condition State Descriptions – Bridge Structures

The condition states listed below are organized by material types that will typically be found on a bridge. The list provided is not intended to be all encompassing but instead is assumed to supplement the inspector's knowledge and experience. The specific bridge elements will refer back to these condition states to comprehensively evaluate each member of a bridge.

Chapter 3.A – Steel

A. Steel

Steel Decks	
28 – Steel Deck with Open Grid	SF
29 – Steel Deck with Concrete Filled Grid	SF
30 – Steel Deck with Corrugated/Orthotropic/Etc.	SF
Superstructure	
102 – Steel Closed Web/Box Girder	LF
107 – Steel Open Girder/Beam	LF
113 – Steel Stringer	LF
120 – Steel Truss	LF
141 – Steel Arch	LF
147 – Steel Main Cables	LF
148 – Secondary Steel Cables	EA
152 – Steel Floor Beam	LF
161 – Steel Pin, Pin & Hanger Assembly or both	EA
162 – Steel Gusset Plate	EA
Substructure	
202 – Steel Column	EA
207 – Steel Tower	LF
219 – Steel Abutment	LF
225 – Steel Pile	EA
231 – Steel Pier Cap	LF
8400 – Integral Wingwall	EA
Culvert	
240 – Steel Culvert	LF

Other	
330 – Metal Bridge Railing	LF
8165 – Steel Tension Rods/Post-Tensioned Cables	EA
8170 – Other Primary Structural Members	LF

Narrative:

- **Element 102** - Steel Closed Web/Box Girders will include all vertical internal diaphragms (plate and cross frames) in box girders. The tied arch girder will be coded under this element.
- **Element 120 and 141** - For through trusses or through arches, the upper bracing (lateral, vertical, portal, and sway) will be evaluated and coded under Assessment 9170 - Truss or Tied/Arch Portal Bracing System. The lower lateral bracing will be evaluated under Assessment 9169 – Lateral Bracing.
- **Element 141** - Steel Arch Tied: Arch bridges shall have the arch section coded under this element, and the tie shall be coded under Element 102 - Steel Closed Web/Box Girder (or other appropriate material girder if not steel)
- **Element 147** - Steel Main Cables is intended for use on the exposed sections (not embedded in concrete) of main cables (typically two) in suspension bridges, or each cable stay in cable-stayed bridges.
- **Element 148** - Secondary Steel Cables will be defined as the exposed sections of suspender cables on suspension bridges, tied arch suspender cables, or dampening cables on cable-stayed bridges.
- **Element 161** - Steel Pin, Pin & Hanger Assembly or both - Distress observed on either plate should be considered. Ultrasonic testing results should be taken into consideration if available.
- **Element 162** - Steel Gusset Plate: Used for gusset plates that connect primary structural members in the load path in the plane of the truss or arch. Nondestructive Testing should be utilized where measurable section loss has occurred. Gusset plates will be measured as one per panel point, regardless of the number of plates used to comprise the connection. Distress observed on built up gusset plates should be considered. Nondestructive testing results should be taken into consideration if available.
- **Element 207** - To be used for truss framed tower supports or built up steel towers and is calculated by the sum of the heights of each tower. This element is intended to capture large supports and towers associated with suspension bridges, cable stayed bridges, movable bridges, or similar structural configurations.
- **Element 515** - The protective coating does not affect the condition state (CS) of the steel elements. Protective coating deterioration will be rated under Element 515, 8516, 8517, 8518, or 8519.
- **Element 8165** - Steel Tension Rods/Post Tension Cables shall be used for tensioning systems that were installed during original construction. Element 8803 – External Post Tensioning shall be used for post tensioning systems that were installed after original construction as a retrofit to provide additional strength to a specific member.

Chapter 3.A - Steel

- **Element 8170** - Other Primary Structural Members: Examples of elements that should be coded under this element include Purlins, Diaphragms on curved steel I-girder bridges (including the diaphragms at the substructures), all external diaphragms joining box girders straight and curved. Diaphragms between straight and kinked I-girders should be coded as Assessment 9167 – Steel Diaphragm.
- **Defect 1000** - Section loss is not defined by a localized area but as the section loss of an entire member by cross-sectional area.
- **Defect 1010** - Any steel cracks not previously detected should be evaluated to determine the potential for fracture. The amount of redundancy and the number of affected primary members will influence the placement of this defect in CS 3 or 4; i.e., the greater the redundancy and/or fewer members that have cracking will most likely be in CS 3.
- **Defect 1900** - Distortion or out of plane bending in compression regions requires greater scrutiny compared to the same level of damage in a tension region.
- **Defect 6000** - Slope settlements should be coded under the applicable slope protection assessment, and should not be coded under the scour defect unless a significant scour event has occurred to wash out the slope paving. Code scour defect for all Piling that are exposed due to scour in addition to the scour under the abutment.

Defect	CS 1	CS 2	CS 3	CS 4
	Good	Fair	Poor	Severe
Material Defects				
Corrosion (1000)	None	Freckled rust. Corrosion of the steel has initiated.	Section loss is evident or pack rust is present but does not warrant structural review.	The condition warrants a structural review to determine the effect on strength or serviceability of the element or bridge; OR a structural review has been completed and the defects impact strength or serviceability of the element or bridge.
Cracking (1010)	None	Crack that has self-arrested or has been arrested with effective arrest holes, doubling plates, or similar.	Identified crack exists that is not arrested but does not warrant structural review.	
Connection (1020)	Connection is in place and functioning as intended.	Loose fasteners or pack rust without distortion is present but the connection is in place and functioning as intended.	Missing bolts, rivets, or fasteners; broken welds; or pack rust with distortion but does not warrant a structural review.	
Distortion (1900)	None	Distortion not requiring mitigation or mitigated distortion.	Distortion that requires mitigation that has not been addressed but does not warrant structural review.	
Structural Defects - Substructure Only				
Settlement (4000)	None	Exists and has been arrested with effective countermeasures.	Minor settlement has occurred. Countermeasures have been taken but movement is still evident. Currently does not warrant a structural review.	The condition warrants a structural review to determine the effect on strength or serviceability of the element or bridge; OR a structural review has been completed and the defects impact strength or serviceability of the element or bridge.
Scour (6000)	None	Scour has exposed the top of the footing. No undermining is evident. Counter measures are in place and functioning. Minor scour around pile bents. No significant loss of channel material compared to previous measurements.	Scour has exposed vertical face(s) of the footing. No undermining of spread footing or minor undermining of pile supported footing. Moderate scour around pile bents. Measurements indicate active channel movement. Structural review not warranted.	

Chapter 3.A - Steel

Defect	CS 1	CS 2	CS 3	CS 4
	Good	Fair	Poor	Severe
Agency Defined Defects				
Microbial Induced Corrosion (8901)	No corrosion exists or it has been repaired or painted over and the water has been tested and no MIC exists.	Water tested and MIC exists. Orange powder may exist but little or no corrosion exists. The surface under the orange powder may be shiny, indicating that MIC is actively attacking the steel member.	Significant section loss exists. Isolated areas of deep pitting and corrosion. Structural capacity is not reduced. Consider recommending cleaning and painting to help prevent further section loss.	The condition warrants a structural review to determine the effect on strength or serviceability of the element or bridge; OR a structural review has been completed and the defects impact strength or serviceability of the element or bridge.
Wingwall Movement (8902)	None	Differential movement has started to occur. Wall may be strapped to prevent further movement.	Wall rotation/sliding/settlement is occurring; sloughing of retained material behind wall is evident.	Wing has failed and no longer retains material behind wall.
Wingwall Deterioration (8903)	None	The wingwall material has deterioration described in the applicable CS 2 material defects for section loss and wall integrity.	The wingwall material has deterioration described in the applicable CS 3 material defects for section loss and wall integrity.	The wingwall material has deterioration/section loss that has caused the wing to fail and no longer retains fill material.

Condition State 2



Condition State 3

Corrosion (1000)



Condition State 4



Cracking (1010)

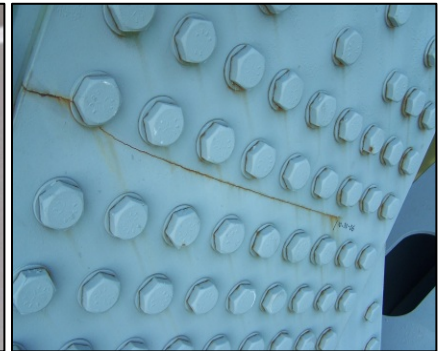
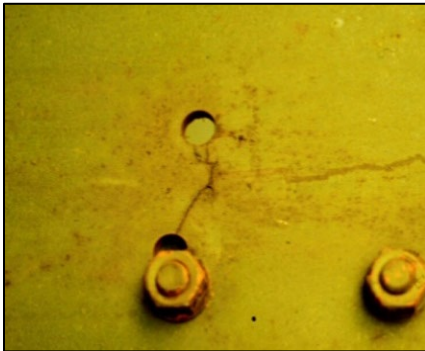

Condition State 2



Condition State 3



Condition State 4



Distortion (1900)

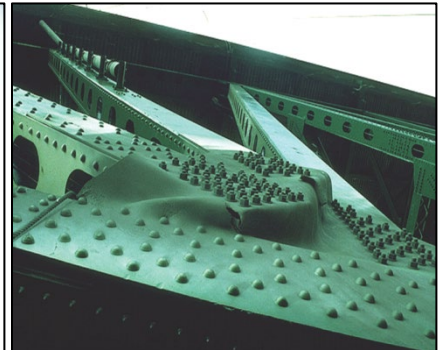

Condition State 2



Condition State 3
Settlement (4000)



Condition State 4



Scour (6000)



Condition State 4 (Severe) - Steel

The items listed below are common situations that would **require** a structural review for **primary structural elements**. This list is not exhaustive; there are situations other than what is listed below that may need a review. It is the responsibility of the inspector to elevate these less-common situations, in addition to the conditions listed below, as is deemed necessary.

Primary Superstructure (102 thru 162, 8165, 8170) & Substructure (202 thru 231) Elements

- **Corrosion (1000)**
 - High-shear areas where the average loss of the web exceeds 10% of web thickness or where corrosion holes exist.
 - High-moment areas where the average loss of the flange exceeds 10% of the flange thickness.
 - Tension members where the section loss exceeds 10% of the gross cross-sectional area.
 - Compression members of arches or trusses where the section loss exceeds 10% of the gross cross-sectional area.
 - Piles or columns where the section loss exceeds 15% of the gross cross-sectional area.
- **Cracking (1010)**
 - Unarrested cracks in fracture critical members
 - Unarrested cracks in flexural members that exceeds 3" in length or a crack that has grown since the last inspection
- **Connection (1020)**
 - Missing bolts or rivets in fracture critical members
 - Members where more than 10% of the connection assembly (welds, fasteners, etc.) are missing, loose or cracked.
- **Distortion (1900)**
 - Compression members that are severely bent, bowed or distorted.
 - Members that have been bent, bowed, or distorted due to impact.

Primary Culvert (240) Element

- **Corrosion (1000)**
 - Loss of section where perforations exist throughout the pipe.
- **Connection (1020)**
 - More than 10% of the fasteners are missing, cracked or heavily deteriorated.
- **Distortion (1900)**
 - Distortion along the length of the culvert in excess of 15% difference from the design dimensions or if the distortion has changed significantly since the last inspection.

Chapter 3.B – Reinforced Concrete

B. Reinforced Concrete

Deck	
12 – Reinforced Concrete Deck	SF
16 – Reinforced Concrete Top Flange	SF
38 – Reinforced Concrete Slab	SF
Superstructure	
105 – Reinforced Concrete Closed Web/Box Girder	LF
110 – Reinforced Concrete Open Girder/Beam	LF
116 – Reinforced Concrete Stringer	LF
144 – Reinforced Concrete Arch	LF
155 – Reinforced Concrete Floor Beam	LF

Substructure	
205 – Reinforced Concrete Column	EA
210 – Reinforced Concrete Pier Wall	LF
215 – Reinforced Concrete Abutment	LF
220 – Reinforced Concrete Pile Cap/Footing	LF
227 – Reinforced Concrete Pile	EA
234 – Reinforced Concrete Cap	LF
8400 – Integral Wingwall	EA
Culvert	
241 – Reinforced Concrete Culvert	LF
Other	
321 – Reinforced Concrete Structural Approach Slab	SF
331 – Reinforced Concrete Bridge Rail	LF
8170 – Other Primary Structural Members	LF

Concrete Cracks		Concrete Scale/Abrasion/Wear	
Crack Widths			
Hairline	<0.012"	Light Scale	<¼" Deep
Narrow	0.012" up to 0.05"	Medium Scale	¼" up to ½" Deep
Medium	0.05" up to 0.1"	Heavy Scale	½" to 1" Deep
Wide	>0.1"	Severe Scale	Loss of aggregate

**The inspector should use judgment when utilizing condition state defect definitions; considering concrete crack type, location, and orientation. Where required, an In-Depth inspection may need to be scheduled so that proper equipment, cleaning, access, traffic control, etc. can be mobilized to assess and properly document any defect's condition state.

Narrative:

- **Element 38** - A concrete rigid frame structure (no floor) shall be evaluated as a concrete slab with concrete abutments.
- **Element 144** - Includes open/closed spandrel arches, earth filled arches, and bow string arches.
- **Element 210** - All web walls and most crash walls attached to a pier shall be assessed 20' from exterior columns and coded under Crash Walls/Web Walls/Cross Bracing or Struts (Assessment 9250), 1 each per substructure unit. The exception is when a crash wall also acts as a pier wall, supporting the vertical load from the pier columns with a full-length foundation. In these instances, code as Pier Wall (210).
- **Element 215** - Includes full depth diaphragms at the abutment which encase the girder ends and retains fill.
- **Element 320** - Both Elements 320 and 321 are for structural approach slabs only. Non-structural approach slabs will be coded under the applicable Assessment. Structural approach slabs will generally have one end resting on the abutment paving notch, and the other end resting on a grade beam.
- **Element 8000** - All reinforced concrete decks will be evaluated from the sides and underside of the deck. The top of the deck will be evaluated with the respective wearing surface. Reinforced concrete decks without a wearing surface will have the top of the deck evaluated under Element 8000 – Wearing Surface (Bare).
- **Element 8400** - Wings on culverts are coded under Element 8400 – Integral Wingwall.
- **Defect 1080** – Sound patched areas include localized patches only, this includes full depth deck repair. Full width rehab joint repair is not considered a patch and other similar cases. Temporary maintenance patches, such as asphalt, will be considered unsound patches. Patched areas under FRP wraps shall be CS 2 or worse.
- **Defect 1130** - Sealed cracks reduce the width of the crack. Newly sealed cracks or sealed cracks without adjacent cracking will be in CS 1.
- **Defect 1190** - Abrasion is the removal of cement paste and/or surface aggregate on piers/bents in rivers from water/sediment/ice flows. It can also occur on the lower 2" to 3" of the concrete curb or concrete railing. Plow abrasions on concrete curbs or rails can be considered along with the abrasion defect, so long as reinforcing steel is not exposed; then it would be considered spalling in the areas of exposed steel.

Chapter 3.B – Reinforced Concrete

- **Defect 4000** - Culvert distortion will be coded through the defect 'Settlement'.
- **Defect 6000** - Slope settlements should be coded under the applicable slope protection assessment, and should not be coded under the scour defect unless a significant scour event has occurred to wash out the slope paving.
- **Defect 8904** - Discoloration defect is for use with deck and slab elements. The intent is to quantify areas of the deck or slab which show signs of higher permeability or water retention. Discoloration from construction materials or locomotive exhaust is not considered a defect. This defect does not require a structural review.
- **Defect 8905** - Chloride Concentration (8905) to be used only where concrete was tested for the presence of chlorides. Refer to the Structure Inspection Manual for current chloride concentration vs. active corrosion threshold.
- **Defect 8907** - Longitudinal separation of segments due to construction placement, movement of the segments, cracks due to thermal effects or shrinkage due to lack of relief joints in original construction. The defect applies to account for culvert connections, precast or prefabricated joints and construction joints for reinforced concrete structures. Vertical movement should still be coded as Settlement (4000).
- **Assessment 9168** - Full depth diaphragms above a pier are considered diaphragm assessments.
- **Assessment 9168** - Partial height diaphragms (> half the height of the girder/beam web) are considered diaphragms. Concrete protrusions less than half the height of the girder/beam web are considered part of the deck.
- **Assessment 9168** - Full height concrete diaphragms that encase the girder/beam ends and retain fill are considered part of the abutment and not coded as an assessment.

Defect	CS 1	CS 2	CS 3	CS 4
	Good	Fair	Poor	Severe
Material Defects				
Delaminations/ Spalls/Patch Areas/Exposed Rebar (1080)	None.	Delaminated. Spalls 1 in. or less deep or less than 6 in. diameter. Reinforcement may be exposed. Corrosion may be present, but without section loss. Patched area that is sound.	Spalls greater than 1 in. deep or greater than 6 in. diameter. Patched area that is unsound or showing distress. Reinforcement present with measurable section loss. Does not warrant structural review.	The condition warrants a structural review to determine the effect on strength or serviceability of the element or bridge; OR a structural review has been completed and the defects impact strength or serviceability of the element or bridge.
Cracking (RC)/ Efflorescence (1130)	No cracks. Hairline cracks not requiring sealing, or cracks that have been sealed. No efflorescence present.	Unsealed cracks of narrow width, or unsealed minor to moderate pattern/map cracking. Efflorescence is present; it's minor with no evidence of rust staining.	Unsealed cracks of medium to wide width, or extensive pattern map cracking. Efflorescence is present; there is heavy build-up and/or rust staining.	
Abrasion/Wear (PSC/RC) (1190)	No abrasion.	Abrasion has exposed coarse aggregate but the aggregate remains secure in the concrete.	Coarse aggregate is loose or has popped out of the concrete matrix due to abrasion.	
Structural Defects - Substructure Only				
Settlement (4000)	None	Exists and has been arrested with effective countermeasures.	Minor settlement has occurred. Countermeasures have been taken but movement is still evident. Currently does not warrant a structural review.	The condition warrants a structural review to determine the effect on strength or serviceability of the element or bridge; OR a structural review has been completed and the

Chapter 3.B – Reinforced Concrete

Defect	CS 1	CS 2	CS 3	CS 4
	Good	Fair	Poor	Severe
Scour (6000)	None	Scour has exposed the top of the footing. No undermining is evident. Counter measures are in place and functioning. Minor scour around pile bents. No significant loss of channel material compared to previous measurements.	Scour has exposed vertical face(s) of the footing. No undermining of spread footing or minor undermining of pile supported footing. Moderate scour around pile bents. Measurements indicate active channel movement. Structural review not warranted.	defects impact strength or serviceability of the element or bridge.
Agency Defined Defects				
Wingwall Movement (8902)	None	Differential movement has started to occur. Wall may be strapped to prevent further movement.	Wall rotation/sliding/settlement is occurring; sloughing of retained material behind wall is evident.	Wing has failed and no longer retains material behind wall.
Wingwall Deterioration (8903)	None	The wingwall material has deterioration described in the applicable CS 2 material defects for section loss and wall integrity.	The wingwall material has deterioration described in the applicable CS 3 material defects for section loss and wall integrity.	The wingwall material has deterioration/section loss that has caused the wing to fail and no longer retains fill material.
Discoloration (8904)	No discoloration of concrete is present.	Concrete is slightly darker than surrounding area; may contain scaling	Medium discoloration; may contain hairline map cracking.	Very dark discoloration. Structural Review not required
Chloride Concentration (8905)	Chloride concentration at level of rebar tested below the threshold for potential active corrosion.	Chloride concentration at level of rebar tested equal to or greater than the threshold for potential active steel corrosion. No visual signs of active corrosion exist.	Chloride concentration at level of rebar tested greater than the threshold for potential active steel corrosion. Testing methods (such as half-cell potential) have been used and have verified active steel corrosion.	Not used for this defect. Other reinforced or prestressed concrete defects control the Condition State over chloride concentrations (elevated levels of chloride concentrations may be cause of controlling defects).

Defect	CS 1	CS 2	CS 3	CS 4
	Good	Fair	Poor	Severe
Precast Concrete Connections (8906)	None	Minor cracking at the joints. Connection is functioning as intended.	Cracking and/or spalling at the joints. No displacement is evident.	Connection is failing or has failed. Condition warrants structural analysis.
Concrete Culvert Connections (8907)	No deficiencies noted.	Minor longitudinal or lateral barrel movement at the joints may be present. The connection is still functioning as intended. No water seepage or loss of backfill is present.	Cracking, spalling, and/or lateral or longitudinal movement indicating that the members are acting independently. Displacement of members is evident, but membranes are still in tack. Water seepage may be present, but fill is still retained.	Connection is failing or has failed. The structural capacity may be affected. Segments may be separating from the adjacent members and the joint has displaced or deteriorated allowing water and backfill to pass through the joint. Members may be acting individually under traffic loads.

Condition State 2

Condition State 3

Condition State 4

Delaminations (1080)



Spalls (1080)



Condition State 2



Condition State 3

Exposed Rebar (1080)



Condition State 4



Cracking – Reinforced Concrete (1130)

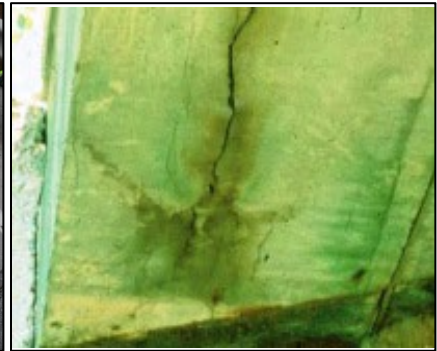

Condition State 2

Condition State 3

Condition State 4

Abrasion/Wear (1190)



Settlement (4000)



Condition State 2



Condition State 3

Scour (6000)



Condition State 4



Discoloration (8904)



Condition State 2

Condition State 3

Condition State 4

Concrete Culvert Connections (8907)



Condition State 4 (Severe) – Reinforced Concrete

The items listed below are common situations that would **require** a structural review for **primary structural elements**. This list is not exhaustive; there are situations other than what is listed below that may need a review. It is the responsibility of the inspector to elevate these less-common situations, in addition to the conditions listed below, as is deemed necessary.

Primary Superstructure (105 thru 155, 8170) and Substructure (205 thru 234) Elements

- **Delamination/Spall/Patched Area/Exposed Rebar (1080)**
 - Impact damage that bends or severs multiple reinforcing steel bars
 - Loss of engagement of reinforcing steel bars with concrete
 - Multiple reinforcing bars exposed with greater than 10% loss of section in high-moment areas
 - Multiple shear stirrup reinforcing bars exposed with greater than 10% loss of section.
- **Cracking/Efflorescence (1130)**
 - Girder or bent cap cracking widths greater than 1/8 Inch near midspan or near/over supports
 - Active shear cracks
- **Scour (6000)**
 - Spread footing is undermined.
 - Pile supported footing has multiple piles with more than one foot of exposure.
 - Scour around pile bents has increased the length of exposed piles more than 4 feet.

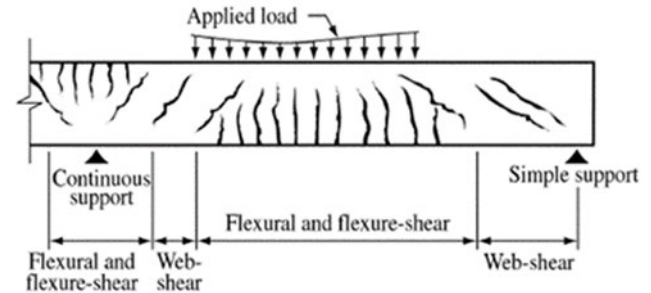

THIS PAGE IS INTENTIONALLY LEFT BLANK

Chapter 3.C – Prestressed Concrete

C. Prestressed Concrete

Deck	
13 – Prestressed Concrete Deck	SF
15 – Prestressed Concrete Top Flange	SF
8039 – Prestressed Concrete Slab	SF
Superstructure	
104 – Prestressed Concrete Closed Web/Box Girder	LF
109 – Prestressed Concrete Open Girder/Beam	LF
115 – Prestressed Concrete Stringer	LF
143 – Prestressed Concrete Arch	LF
154 – Prestressed Concrete Floor Beam	LF

Substructure	
204 – Prestressed Concrete Column	EA
226 – Prestressed Concrete Pile	EA
233 – Prestressed Concrete Cap	LF
8400 – Integral Wingwall	EA
Culvert	
245 – Prestressed Concrete Culvert	LF
Other	
320 – Prestressed Concrete Structural Approach Slab	SF
8170 – Other Primary Structural Members	LF

Concrete Cracks		Concrete Scale/Abrasion/Wear	
	Prestressed		
Hairline	<.004"	Light Scale	¼" Deep
Narrow	.004" to .009"	Medium Scale	¼" to ½" Deep
Medium	.01" to .03"	Heavy Scale	½" to 1" Deep
Wide	>.03"	Severe Scale	Loss of aggregate

**The inspector should use judgment when utilizing condition state defect definitions; considering concrete crack type, location, and orientation. Where required, an In-Depth inspection may need to be scheduled so that proper equipment, cleaning, access, traffic control, etc... can be mobilized to assess and properly document any defect's condition state.

Narrative:

- **Element 320 & 321** - Both Elements 320 and 321 are for structural approach slabs only. Non-structural approach slabs will be coded under the applicable Assessment. Structural approach slabs will have one end resting on the abutment paving notch, and the other end resting on a grade beam.
- **Element 8000** - All prestressed concrete decks will be evaluated from the sides and underside of the deck. The top of the deck will be evaluated with the respective wearing surface. Prestressed concrete decks without a wearing surface will have the top of the deck evaluated under Element 8000 – Wearing Surface (Bare).
- **Element 8039** - Prestressed Concrete Slab: Examples of elements that should be coded under these elements include solid prestressed slabs, hollow core prestressed slabs, inverted prestressed T-beams, etc.
- **Defect 1080** - Concerns with exposed prestressing tendons in concrete elements are more severe than that of exposed reinforced concrete. Deterioration and damage to concrete surrounding the prestressed tendons can relieve the tension within the prestressed strands, reducing the strength of the prestressed member. Corrosion to prestressing strands can also reduce the strength of the member. Cracking in prestressed members should be scrutinized carefully as any cracking wider than a tight crack can signify the member is losing its bond between the prestressing strands and the concrete.
- **Defect 1080** – Sound patched areas include localized patches only, this includes full depth deck repair. Full width rehab joint repair is not considered a patch and other similar cases. Temporary maintenance patches, such as asphalt, will be considered unsound patches. Patched areas under FRP wraps shall be CS 2 or worse.
- **Defect 1190** - Abrasion is the removal of cement paste and/or surface aggregate on piers/bents in rivers from water/sediment/ice flows. Abrasion can also occur in the flow line on top of the bridge deck. It will be noted at the extreme edge of the deck surface and the lower 2” to 3” of the concrete parapet wall.
- **Defect 4000** - Culvert distortion defects will be coded through the defect ‘Settlement’.
- **Defect 6000** - Slope settlements should be coded under the applicable slope protection assessment, and should not be coded under the scour defect unless a significant scour event has occurred to wash out the slope paving.
- **Defect 8904** - Discoloration defect is for use with deck and slab elements. The intent is to quantify areas of the deck or slab which show signs of higher permeability or water retention. Discoloration from construction materials or locomotive exhaust is not considered a defect. This defect does not require a structural review.
- **Defect 8905** - Chloride Concentration to be used only on those bridges in a chloride testing program. Refer to the Structure Inspection Manual for current chloride concentration vs. active corrosion threshold.
- **Defect 8906** - Precast Concrete Connections: Intended to be used for the connections between precast elements, such as shear keys along precast panels to identify differential movement, or the grouted joints poured between elements during Accelerated Bridge Construction.

Chapter 3.C – Prestressed Concrete

- Defect 8907** - Longitudinal separation of segments due to construction placement, movement of the segments, cracks due to thermal effects or shrinkage due to lack of relief joints in original construction. The defect applies to account for culvert connections, precast or prefabricated joints and construction joints for reinforced concrete structures. Vertical movement should still be coded as Settlement (4000).

Defect	CS 1	CS 2	CS 3	CS 4
	Good	Fair	Poor	Severe
Material Defects				
Delaminations/ Spalls/Patch Areas/Exposed Prestressing (1080)	None.	Delaminated. Spalls 1 in. or less deep or less than 6 in. diameter. Reinforcing steel exposed. Corrosion may be present, but without section loss. Prestressing strands may be exposed without corrosion. Patched area that is sound.	Spalls greater than 1 in. deep or greater than 6 in. diameter. Patched area that is unsound or showing distress. Reinforcing steel present with measurable section loss. Prestressing strands exposed with corrosion. Does not warrant structural review.	The condition warrants a structural review to determine the effect on strength or serviceability of the element or bridge; OR a structural review has been completed and the defects impact strength or serviceability of the element or bridge.
Cracking (PSC) (1110)	Width less than 0.004 in. or sealed cracks.	Width 0.004 – 0.009 in. Where efflorescence is present, it's minor and no evidence of rust staining.	Width greater than 0.009 in. Where efflorescence is present, there is heavy build-up and/or rust staining.	
Abrasion/Wear (PSC/RC) (1190)	No abrasion.	Abrasion has exposed coarse aggregate but the aggregate remains secure in the concrete.	Coarse aggregate is loose or has popped out of the concrete matrix due to abrasion.	The condition warrants a structural review to determine the effect on strength or serviceability of the element or bridge; OR a structural review has been completed and the defects impact strength or serviceability of the element or bridge.

Defect	CS 1	CS 2	CS 3	CS 4
	Good	Fair	Poor	Severe
Structural Defects - Substructure Only				
Settlement (4000)	None	Exists and has been arrested with effective countermeasures.	Minor settlement has occurred. Countermeasures have been taken but movement is still evident. Currently does not warrant a structural review.	The condition warrants a structural review to determine the effect on strength or serviceability of the element or bridge; OR a structural review has been completed and the defects impact strength or serviceability of the element or bridge.
Scour (6000)	None	Scour has exposed the top of the footing. No undermining is evident. Counter measures are in place and functioning. Minor scour around pile bents. No significant loss of channel material compared to previous measurements.	Scour has exposed vertical face(s) of the footing. No undermining of spread footing or minor undermining of pile supported footing. Moderate scour around pile bents. Measurements indicate active channel movement. Structural review not warranted.	
Agency Defined Defects				
Wingwall Movement (8902)	None	Differential movement has started to occur. Wall may be strapped to prevent further movement	Wall rotation/sliding/settlement is occurring; sloughing of retained material behind wall is evident.	Wing has failed and no longer retains material behind wall.
Wingwall Deterioration (8903)	None	The wingwall material has deterioration described in the applicable CS 2 material defects for section loss and wall integrity.	The wingwall material has deterioration described in the applicable CS 3 material defects for section loss and wall integrity.	The wingwall material has deterioration/section loss that has caused the wing to fail and no longer retains fill material.

Chapter 3.C – Prestressed Concrete

Defect	CS 1	CS 2	CS 3	CS 4
	Good	Fair	Poor	Severe
Discoloration (8904)	No discoloration of concrete is present.	Concrete is slightly darker than surrounding area; may contain scaling	Medium discoloration; may contain hairline map cracking.	Very dark discoloration. Structural Review not required
Chloride Concentration (8905)	Chloride concentration at level of rebar tested below the threshold for potential active corrosion.	Chloride concentration at level of rebar tested equal to or greater than the threshold for potential active steel corrosion. No visual signs of active corrosion exist.	Chloride concentration at level of rebar tested greater than the threshold for potential active steel corrosion. Testing methods (such as half-cell potential) have been used and have verified active steel corrosion.	Not used for this defect. Other reinforced or prestressed concrete defects control the Condition State over chloride concentrations (elevated levels of chloride concentrations may be cause of controlling defects).
Precast Concrete Connections (8906)	None	Minor cracking at the joints. Connection is functioning as intended.	Cracking and/or spalling at the joints. No displacement is evident.	Connection is failing or has failed. Condition warrants structural analysis.
Concrete Culvert Connections (8907)	No deficiencies noted.	Minor longitudinal or lateral barrel movement at the joints may be present. The connection is still functioning as intended. No water seepage or loss of backfill is present.	Cracking, spalling, and/or lateral or longitudinal movement indicating that the members are acting independently. Displacement of members is evident, but membranes are still in tack. Water seepage may be present, but fill is still retained.	Connection is failing or has failed. The structural capacity may be affected. Segments may be separating from the adjacent members and the joint has displaced or deteriorated allowing water and backfill to pass through the joint. Members may be acting individually under traffic loads.

Condition State 2



Condition State 3

Delaminations (1080)



Condition State 4



Spalls (1080)



Condition State 2



Condition State 3

Exposed Prestressing (1080)



Condition State 4

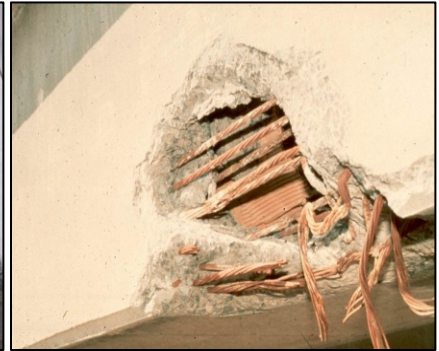

Cracking – Prestressed (1110)



Condition State 2



Condition State 3

Abrasion/Wear (1190)



Condition State 4



Settlement (4000)



Condition State 2



Condition State 3

Scour (6000)



Condition State 4



Discoloration (8904)



Condition State 2

Condition State 3

Condition State 4

Concrete Culvert Connections (8907)



Condition State 4 (Severe) – Prestressed Concrete

The items listed below are common situations that would **require** a structural review for **primary structural elements**. This list is not exhaustive; there are situations other than what is listed below that may need a review. It is the responsibility of the inspector to elevate these less-common situations, in addition to the conditions listed below, as is deemed necessary.

Primary Superstructure (104 thru 154, 8170) and Substructure (204 thru 233) Elements

- **Delamination/Spall/Patched Area/Exposed Prestressing (1080)**
 - Impact damage that bends or severs a strand
 - Unsound concrete at or behind prestressing steel (excluding girder ends)
 - Exposed strand with section loss or broken wires
 - Multiple shear stirrup reinforcing bars exposed with greater than 10% loss of section.
 - Girder at bearing has more than 20% loss of concrete section
- **Cracking/Efflorescence (1110)**
 - Girder or bent cap flexural cracking widths greater than 1/32 Inch near midspan or near/over supports (i.e. visible from ground)
 - Active shear cracks
- **Scour (6000)**
 - Pile supported footing has multiple piles with more than one foot of exposure.
 - Scour around pile bents has increased the length of exposed piles more than 4 feet.

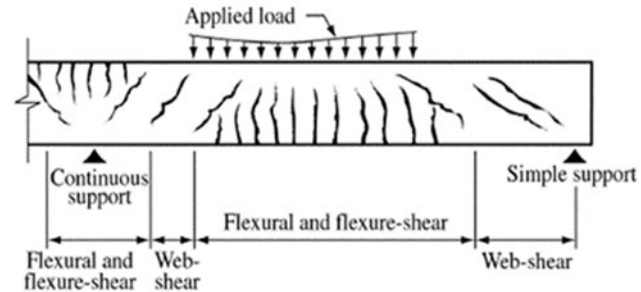

Chapter 3.D – Timber

D. Timber

Deck	
31 – Timber Deck	SF
54 – Timber Slab	SF
Superstructure	
111 – Timber Open Girder/Beam	LF
117 – Timber Stringer	LF
135 – Timber Truss	LF
146 – Timber Arch	LF
156 – Timber Floor Beam	LF
8166 – Timber Spreader Beam	LF
Substructure	
206 – Timber Column	EA
208 – Timber Trestle	LF
212 – Timber Pier Wall	LF
216 – Timber Abutment	LF
228 – Timber Pile	EA
235 – Timber Pier Cap	LF
8400 – Integral Wingwall	EA
Culvert	
242 – Timber Culvert	LF
Other	
332 – Timber Railing	LF
8170 – Other Primary Structural Members	LF

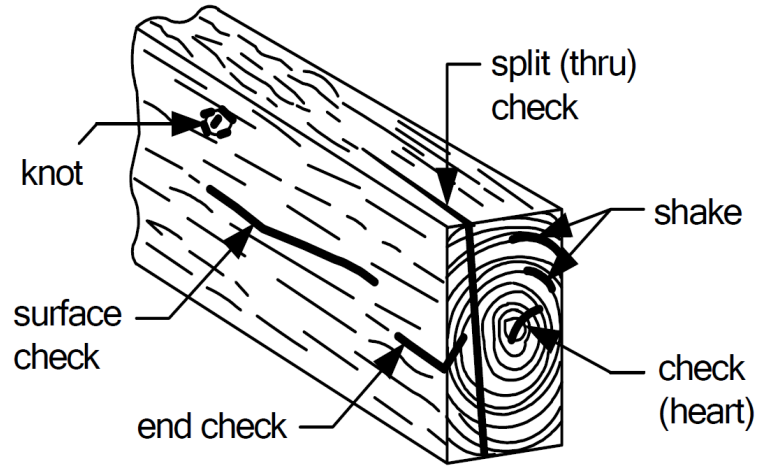

Narrative:

- **Element 31** - The deck or slab may be longitudinally or transversely laminated, or constructed of planks, and may or may not be constructed with spreader beams or runners of metal or wood. Report the condition state that represents the condition of the bottom and sides of element.
- **Element 208** - To be used for truss framed trestle or towers. This element is intended to capture large supports and towers associated with large deck truss bridges.
- **Element 216** – Reinforced concrete diaphragms on timber abutments shall be coded as assessment 9168 Concrete Diaphragm.
- **Element 8000** - All timber decks will be evaluated from the sides and underside of the deck. The top of the deck will be evaluated with the respective wearing surface. Timber decks without a wearing surface will have the top of the deck evaluated under Element 8000 – Wearing Surface (Bare).
- **Element 8166** - Timber Spreader Beam: Are reported as separate elements due to their effect on load capacity. Uneven timber slab laminations and gaps between the bottom of slab and top of the spreader beam from loose connections or distortion shall be noted as Condition State 4.
- **Defect 1140** - Timber decay is most likely to occur in any areas of wetting and drying, at soil lines and water lines, flat areas that collect water, particularly where dirt and other debris is built up, and areas where the protective system, if present, is ineffective.
- **Defect 1140** - Insect infestation can also be the cause of timber section loss and would be evaluated under Defect 1140.
- **Defect 1150** - Delaminations in timber members are generally found in glue and stress laminated members. Glue laminated timber members should be checked for delamination as the load carrying capacity could be affected. If delamination is noted in stress laminated members, the adjacent post-tensioning rods/bolts should be checked to verify adequate tension.
- **Defect 1900** - Vertical separation of timber lagging in a timber abutment shall be captured with the distortion defect including a comment on the inspection report. Note the condition of steel tieback hardware found in timber piles under the distortion defect. If no movement of the timber pile exists code as condition state 1. Recommend a maintenance action for loose or missing hardware.
- **Defect 6000** - Slope settlements should be coded under the applicable slope protection assessment, and should not be coded under the scour defect unless a significant scour event has occurred to wash out the slope paving.

Chapter 3.D – Timber

Defect	CS 1	CS 2	CS 3	CS 4
	Good	Fair	Poor	Severe
Material Defects				
Connection (1020)	Connection is in place and functioning as intended.	Loose fasteners or pack rust without distortion is present but the connection is in place and functioning as intended.	Missing bolts, rivets, or fasteners; broken welds; or pack rust with distortion but does not warrant a structural review.	The condition warrants a structural review to determine the effect on strength or serviceability of the element or bridge; OR a structural review has been completed and the defects impact strength or serviceability of the element or bridge.
Decay/ Section Loss/Abrasion/ Wear (1140)	None	Affects less than 10% of the member section.	Affects 10% or more of the member section, but does not warrant structural review.	
Checks/Shakes/ Cracks/Splits/ Delamination (1150)	Checks/Cracks penetrate <5% of member thickness. Member does not have Splits/Shakes/Delamination.	Checks/Cracks penetrate 5%-50% of member thickness and not in tension zone. Member has Splits/Shakes with length less than member depth. Larger Cracks/Splits/Shakes have been arrested with effective repair.	Checks/Cracks penetrate >50% of member thickness or >5% in tension zone. Member has Splits/Shakes with length greater than member depth and have not been arrested. Defects do not require a structural review.	
Distortion (1900)	None	Distortion not requiring mitigation or mitigated distortion.	Distortion that requires mitigation that has not been addressed.	

Defect	CS 1	CS 2	CS 3	CS 4
	Good	Fair	Poor	Severe
Structural Defects - Substructure Only				
Settlement (4000)	None	Exists and has been arrested with effective countermeasures.	Minor settlement has occurred. Countermeasures have been taken but movement is still evident. Currently does not warrant a structural review.	The condition warrants a structural review to determine the effect on strength or serviceability of the element or bridge; OR a structural review has been completed and the defects impact strength or serviceability of the element or bridge.
Scour (6000)	None	Scour has exposed the top of the footing. No undermining is evident. Counter measures are in place and functioning. Minor scour around pile bents. No significant loss of channel material compared to previous measurements.	Scour has exposed vertical face(s) of the footing. No undermining of spread footing or minor undermining of pile supported footing. Moderate scour around pile bents. Measurements indicate active channel movement. Structural review not warranted.	
Agency Defined Defects				
Wingwall Movement (8902)	None	Differential movement has started to occur. Wall may be strapped to prevent further movement.	Wall rotation/sliding/settlement is occurring; sloughing of retained material behind wall is evident.	Wing has failed and no longer retains material behind wall.
Wingwall Deterioration (8903)	None	The wingwall material has deterioration described in the applicable CS 2 material defects for section loss and wall integrity.	The wingwall material has deterioration described in the applicable CS 3 material defects for section loss and wall integrity.	The wingwall material has deterioration/section loss that has caused the wing to fail and no longer retains fill material.

Condition State 2

Condition State 3

Condition State 4

Connection (1020)



Decay/Section Loss (1140)



Condition State 2



Condition State 3

Checks/Shakes (1150)



Condition State 4

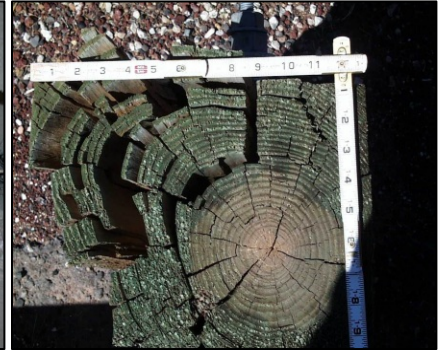

Cracks (1150)



Condition State 2

Condition State 3

Condition State 4

Splits/Delaminations (1150)



Abrasion/Wear (1140)



Condition State 2



Condition State 3

Wear (1140)



Condition State 4



Settlement (4000)



Condition State 2



Condition State 3

Scour (6000)



Condition State 4



Condition State 4 (Severe) – Timber

The items listed below are common situations that would **require** a structural review for **primary structural elements**. This list is not exhaustive; there are situations other than what is listed below that may need a review. It is the responsibility of the inspector to elevate these less-common situations, in addition to the conditions listed below, as is deemed n

ecessary.

Primary Superstructure (111 thru 8166, 8170) and Substructure (206 thru 235) Elements

- **Connection (1020)**
 - Timber Spreader Beam is loose or has multiple gaps between beam and slab.
 - Multiple broken or missing bolts, screws, or fasteners
- **Decay/Section Loss/Abrasion/Wear (1140)**
 - Affects more than 20% of the member section.
- **Checks/Shakes/Cracks/Splits/Delamination (1150)**
 - Checks or Shakes penetrate >75% of the member thickness or >25% in a tension zone.
- **Distortion (1900)**
 - Members that are visibly crushing by more than ½ inch.
 - Abutment caps twisting with more than 50% of the bearing area is no longer in contact.
 - Piles that are continuing to shift out of plumb from inspection to inspection, or are out of plumb by more than 15 degrees from the original driven condition.
- **Scour (6000)**
 - Pile supported footing has multiple piles with more than one foot of exposure.
 - Scour around pile bents has increased the length of exposed piles more than 4 feet.

THIS PAGE IS INTENTIONALLY LEFT BLANK

Chapter 3.E – Masonry

E. Masonry

Superstructure	
145 – Masonry Arch	LF
Substructure	
213 – Masonry Pier Wall	LF
217 – Masonry Abutment	LF
8400 – Integral Wingwall	EA
Culvert	
244 – Masonry Culvert	LF
Other	
334 – Masonry Bridge Railing	LF
8170 – Other Primary Structural Members	LF

Narrative:

- Faux masonry elements (i.e. precast concrete blocks, reinforced concrete blocks, etc.) will not be rated under this set of elements. These types of material will be rated under “Other Materials”.
- **Defect 6000** - Slope settlements should be coded under the applicable slope protection assessment, and should not be coded under the scour defect unless a significant scour event has occurred to wash out the slope paving.

Defect	CS 1	CS 2	CS 3	CS 4
	Good	Fair	Poor	Severe
Material Defects				
Mortar Breakdown (1610)	None	Cracking or voids in less than 10% of joints.	Cracking or voids in 10% or more of the joints.	The condition warrants a structural review to determine the effect on strength or serviceability of the element or bridge; OR a structural review has been completed and the defects impact strength or serviceability of the element or bridge.
Splits/Spall/Patched Area (1620)	None	Block or stone has split or spalled with no shifting. Patched area is sound.	Block or stone has split or spalled with shifting but does not warrant a structural review. Patched area is not sound.	
Masonry Displacement (1640)	None	Block or stone has shifted slightly out of alignment.	Block or stone has shifted significantly out of alignment or is missing but does not warrant structural review.	
Structural Defects - Substructure Only				
Settlement (4000)	None	Exists and has been arrested with effective countermeasures.	Minor settlement has occurred. Countermeasures have been taken but movement is still evident. Currently does not warrant a structural review.	The condition warrants a structural review to determine the effect on strength or serviceability of the element or bridge; OR a

Chapter 3.E – Masonry

Defect	CS 1	CS 2	CS 3	CS 4
	Good	Fair	Poor	Severe
Scour (6000)	None	Scour has exposed the top of the footing. No undermining is evident. Counter measures are in place and functioning. Minor scour around pile bents. No significant loss of channel material compared to previous measurements.	Scour has exposed vertical face(s) of the footing. No undermining of spread footing or minor undermining of pile supported footing. Moderate scour around pile bents. Measurements indicate active channel movement. Structural review not warranted.	structural review has been completed and the defects impact strength or serviceability of the element or bridge.
Agency Defined Defects				
Wingwall Movement (8902)	None	Differential movement has started to occur. Wall may be strapped to prevent further movement.	Wall rotation/sliding/settlement is occurring; sloughing of retained material behind wall is evident.	Wing has failed and no longer retains material behind wall.
Wingwall Deterioration (8903)	None	The wingwall material has deterioration described in the applicable CS 2 material defects for section loss and wall integrity.	The wingwall material has deterioration described in the applicable CS 3 material defects for section loss and wall integrity.	The wingwall material has deterioration/section loss that has caused the wing to fail and no longer retains fill material.

Condition State 2



Condition State 3

Mortar Breakdown (1610)



Condition State 4



Split/Spall/Patched Area (1620)



Condition State 2

Condition State 3

Condition State 4

Masonry Displacement (1640)



Settlement (4000)



Condition State 2



Condition State 3

Scour (6000)



Condition State 4



Condition State 4 (Severe) – Masonry

The items listed below are common situations that would **require** a structural review for **primary structural elements**. This list is not exhaustive; there are situations other than what is listed below that may need a review. It is the responsibility of the inspector to elevate these less-common situations, in addition to the conditions listed below, as is deemed necessary.

Primary Superstructure (145, 8170) and Substructure (213 and 217) Elements

- **Masonry Displacement (1640)**
 - Three or more tipping, bulging, rotating, or missing blocks or stones.
- **Settlement (4000)**
 - Any global tipping, bulging, or rotating of a substructure unit.
- **Scour (6000)**
 - Footings are undermined.

Chapter 3.F – Other Materials

F. Other Materials

Deck	
60 – Other Material Deck	SF
65 – Other Material Slab	SF
Superstructure	
106 – Other Material Closed Web/Box Girder	LF
112 – Other Material Open Girder/Beam	LF
118 – Other Material Stringer	LF
136 – Other Material Truss	LF
142 – Other Material Arch	LF
157 – Other Material Floor Beam	LF
Substructure	
203 – Other Material Column	EA
211 – Other Material Pier Wall	LF
218 – Other Material Abutment	LF
229 – Other Material Pile	EA
236 – Other Material Pier Cap	LF
8400 – Integral Wingwall	EA
Culvert	
243 – Other Material Culvert	LF
Other	
333 – Other Material Bridge Railing	LF
8170 – Other Primary Structural Members	LF

Narrative:

- Elements constructed of materials not already identified should use the “Other” category in order to capture their quantity and condition. Examples of this may include FRP or other plastics, aluminum, or stainless steel.
- **Element 218** - GRS and Precast abutments are included in (218) Other Abutments.
- **Element 243** - Other Material Culvert includes plastic, aluminum, and composite culverts
- **Defect 1080** - The use of commercially available rapid setting bagged concrete will be considered an unsound patch. Only pre-approved concrete products that have been appropriately wet cured will be considered a sound patch.
- **Defect 6000** - Slope settlements should be coded under the applicable slope protection assessment, and should not be coded under the scour defect unless a significant scour event has occurred to wash out the slope paving.

Defect	CS 1	CS 2	CS 3	CS 4
	Good	Fair	Poor	Severe
Material Defects				
Corrosion (1000)	None	Freckled rust. Corrosion of the steel has initiated.	Section loss is evident or pack rust is present but does not warrant structural review.	The condition warrants a structural review to determine the effect on strength or serviceability of the element or bridge; OR a structural review has been completed and the defects impact strength or serviceability of the element or bridge.
Cracking (1010)	None	Crack that has self-arrested or has been arrested with effective arrest holes, doubling plates, or similar.	Identified crack exists that is not arrested but does not warrant structural review.	
Connection (1020)	Connection is in place and functioning as intended.	Loose fasteners or pack rust without distortion is present but the connection is in place and functioning as intended.	Missing bolts, rivets, broken welds, fasteners or pack rust with distortion but does not warrant a structural review.	
Delaminations/ Spalls/Patch Areas/Exposed Rebar (1080)	None.	Delaminations/Spalls 1 in. or less deep or less than 6 in. diameter. Reinforcement may be exposed. Corrosion may be present, but without section loss. Patched area that is sound.	Delaminations/Spalls greater than 1 in. deep or greater than 6 in. diameter. Patched area that is unsound or showing distress. Reinforcement present with measurable section loss. Does not warrant structural review.	
Deterioration (1220)	None	Initiated breakdown or deterioration.	Significant deterioration or breakdown, but does not warrant a structural review.	
Distortion (1900)	None	Distortion not requiring mitigation or mitigated distortion.	Distortion that requires mitigation that has not been addressed.	

Chapter 3.F – Other Materials

Defect	CS 1	CS 2	CS 3	CS 4
	Good	Fair	Poor	Severe
Structural Defects - Substructure Only				
Settlement (4000)	None	Exists and has been arrested with effective countermeasures.	Minor settlement has occurred. Countermeasures have been taken but movement is still evident. Currently does not warrant a structural review.	The condition warrants a structural review to determine the effect on strength or serviceability of the element or bridge; OR a structural review has been completed and the defects impact strength or serviceability of the element or bridge.
Scour (6000)	None	Scour has exposed the top of the footing. No undermining is evident. Counter measures are in place and functioning. Minor scour around pile bents. No significant loss of channel material compared to previous measurements.	Scour has exposed vertical face(s) of the footing. No undermining of spread footing or minor undermining of pile supported footing. Moderate scour around pile bents. Measurements indicate active channel movement. Structural review not warranted.	
Agency Defined Defects				
Wingwall Movement (8902)	None	Differential movement has started to occur. Wall may be strapped to prevent further movement.	Wall rotation/sliding/settlement is occurring; sloughing of retained material behind wall is evident.	Wing has failed and no longer retains material behind wall.
Wingwall Deterioration (8903)	None	The wingwall material has deterioration described in the applicable CS 2 material defects for section loss and wall integrity.	The wingwall material has deterioration described in the applicable CS 3 material defects for section loss and wall integrity.	The wingwall material has deterioration/section loss that has caused the wing to fail and no longer retains fill material.

Chapter 3.G – Bearings

G. Bearings

310 – Elastomeric Bearing	EA
311 – Moveable Bearing	EA
313 – Fixed Bearing	EA
314 – Pot Bearing	EA
315 – Disc Bearing	EA
316 – Other Bearing	EA

Narrative

- The primary concern with bearings is their ability to function as designed; to allow for expansion, contraction and rotation of the bridge superstructure. Inspectors should look at the alignment of the joints and bridge rail for indications that the bearings are not functioning properly. The mechanical functionality and condition of the bearings is also considered. Measurements of movement and displacement are often necessary for a complete evaluation.
- The loads are transferred through the bearings from the superstructure elements into the substructure. Deficiencies in the superstructure and substructure can also result from issues with the performance and functionality of the bearings.
- Bearings should only be reported if visible. A bridge with the girders cast into the end diaphragms will have no bearings reported, since bearings are not visible. Inspectors should be aware there are configurations where the girder rests on a single steel plate or elastomeric pad. These are not to be considered bearings and any defects shall be noted with the girder element.
- In extreme situations, bearing condition may affect NBI Condition Rating of the Superstructure. Otherwise it will not be considered in NBI Condition Ratings.
- **Element 310** - Includes elastomeric and laminated bearing pads, but not thin, non-laminated bearing pads.
- **Element 311** - Includes rocker bearings, roller bearings, sliding bearings etc.
- **Element 314 & 315** - Primarily used on large structures and railroad bridges.
- **Defect 2210** - For steel movable bearings with Teflon that is walking out shall be coded under the movement defect.
- **Defect 2230** - The bulging, splitting, or tearing defect is only used for elastomeric bearings.
- **Defect 2240** - Loss of Bearing Area defect refers to contact between masonry plate/bearing pad and beam seat, or can be the deterioration around the masonry plate causing instability. This can also be used for the contact between the bearing and the girder.

Bearing Types

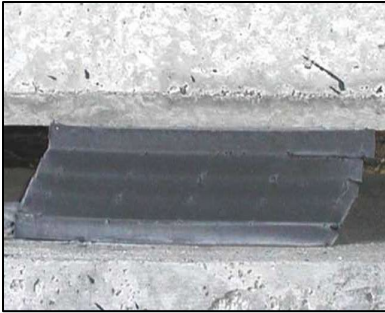

310 – Elastomeric Bearing



311 – Movable Bearing



313 – Fixed Bearing



314 – Pot Bearing



315 – Disc Bearing

Chapter 3.G - Bearings

Defect	CS 1	CS 2	CS 3	CS 4
	Good	Fair	Poor	Severe
Corrosion (1000)	None	Freckled Rust. Corrosion of the steel has initiated.	Section loss is evident or pack rust is present but does not warrant structural review.	The condition warrants a structural review to determine the effect on strength or serviceability of the element or bridge; OR a structural review has been completed and the defects impact strength or serviceability of the element or bridge.
Connection (1020)	Connection is in place and functioning as intended.	Loose fasteners or pack rust without distortion is present but the connection is in place and functioning as intended.	Missing bolts, rivets, broken welds, fasteners or pack rust with distortion but does not warrant a structural review.	
Movement (2210)	Free to move.	Minor restriction.	Restricted but not warranting structural review.	
Alignment (2220)	Lateral and vertical alignment is as expected for the temperature conditions.	Tolerable lateral or vertical alignment that is inconsistent with the temperature conditions.	Approaching the limits of lateral or vertical alignment for the bearing but does not warrant a structural review.	
Bulging, Splitting, or Tearing (2230)	None	Bulging less than 15% of the thickness.	Bulging 15% or more of the thickness. Splitting or tearing. Bearing's surfaces are not parallel. Does not warrant structural review.	
Loss of Bearing Area (2240)	None	Less than 10%.	10% or more but does not warrant structural review.	

Condition State 2



Condition State 3
Corrosion (1000)



Condition State 4



Connection (1020)



Condition State 2



Condition State 3
Movement (2210)



Condition State 4



Alignment (2220)



Condition State 2

Condition State 3

Condition State 4

Bulging/Splitting/Tearing (2230)



Loss of Bearing Area (2240)



THIS PAGE IS INTENTIONALLY BLANK

Chapter 3.H – Joints

H. Joints

300 – Strip Seal Expansion Joint	LF
301 – Pourable Joint Seal	LF
302 – Compression Joint Seal	LF
303 – Modular Joint	LF
304 – Open Expansion Joint	LF
305 – Assembly Joint without Seal	LF
306 – Other Joint	LF

Narrative:

- Joints will be inventoried when:
 - There is a discontinuity in deck reinforcement
 - There is a discontinuity in superstructure
 - There are bearings supporting adjacent superstructure spans
 - When there is a gap between deck and abutment backwall
 - The joints will NOT be inventoried when there is a discontinuity between:
 - The deck and a structural approach slab
 - The deck and a non-structural approach slab
 - A structural approach slab and a non-structural approach slab
- The primary function of a deck joint is to accommodate the expansion, contraction, and rotation of the superstructure.
 - Inspector should determine fixity of joint location when making assessment on debris impactation (i.e. joint at fixed bearing location, debris will not impact movement)
 - The joint must also provide a smooth transition between adjoining segments of bridge deck.
 - Construction joints (longitudinal and transverse) will not be rated under the joint elements. It may be necessary to review bridge plans to distinguish between sealed construction joints and Pourable Joint Seals.
 - Longitudinal joints used for expansion/contraction will be coded as a joint under the applicable element.
 - The quantity should include the sum of the lengths of the joints measured along the centerline of the joint (possible skew angle), not the perpendicular width of the bridge deck.
 - Some joint types, like Element 305 may be covered with an AC Overlay. It is the inspector's responsibility to verify, note, and record joint condition by underside and other visible indicators.

Joint Types

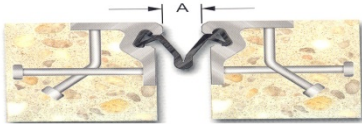

300 - Strip Seal Expansion Joint

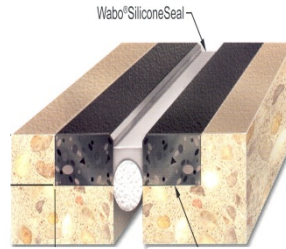

301 - Pourable Joint Seal

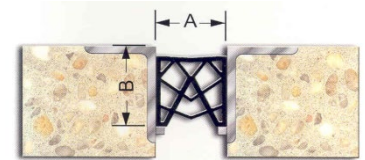

302 - Compression Joint Seal

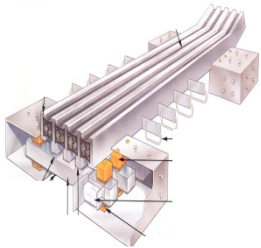

303 - Modular Joint

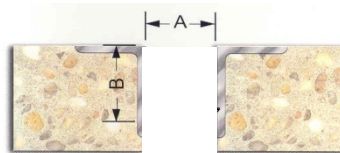

304 - Open Expansion Joint



305 - Assembly Joint without Seal

Chapter 3.H - Joints

Defect	CS 1	CS 2	CS 3	CS 4
	Good	Fair	Poor	Severe
Leakage, Seal Adhesion/ Damage/ Cracking (2310)	Fully Adhered.	Minimal leakage minor dripping through the joint. Seal adhered for more than 50% of the joint height. Seal abrasion without through punctures/cracks.	Moderate leakage. Seal adhered 50% or less of joint height but still some adhesion. Punctured, cracked, or ripped or partially pulled out.	Free flow of water through the joint. Complete loss of seal adhesion. Punctured/cracked/teared completely through, pulled out, or missing.
Debris Impaction (2350)	No debris to a shallow cover of loose debris may be evident but does not affect the performance of the joint.	Partially filled with hard-packed material, but still allowing free movement.	Completely filled and impacts joint movement.	Completely filled and prevents joint movement.
Adjacent Deck or Header/ Metal Deterioration or Damage (2360)	Sound.	Edge delamination or spall 1 in. or less deep, or 6 in. or less in diameter. No exposed rebar. Patched area that is sound. Freckled rust, metal has no cracks, or impact damage. Connection may be loose but functioning as intended.	Spall greater than 1 in. deep or greater than 6 in. diameter. Exposed rebar. Delamination or unsound patched area that makes the joint loose. Section loss, missing or broken fasteners, cracking of the metal or impact damage but joint still functioning.	Spall, delamination, unsound patched area or loose joint anchor that prevents the joint from functioning as intended. Metal cracking, section loss, damage or connection failure that prevents the joint from functioning as intended.

Condition State 2

Condition State 3

Condition State 4

Leakage/Seal Adhesion/Damage/Cracking (2310)



Debris Impaction (2350)

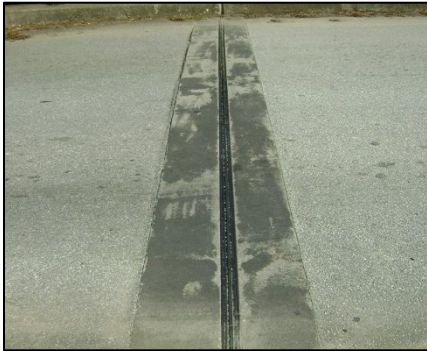

Condition State 2

Condition State 3

Condition State 4

Adjacent Deck or Header/Metal Deterioration or Damage (2360)



Chapter 3.1 – Steel Protective Coatings

I. Steel Protective Coatings

515 – Steel Protective Coating - Other	SF
8516 – Painted Steel	SF
8517 – Weathering Steel	SF
8518 – Galvanization	SF
8519 – Duplex Systems	SF

Narrative:

- The presence of lead paint is possible and should be considered when performing inspections. Any feasible actions for paint systems should also identify the presence of lead paint.
- Steel Protective Coatings will be calculated for all steel superstructure elements, as well as primary steel substructure elements (pier caps, piles, columns, towers, and abutments).
- **Elements 515, 8516, 8517, 8518, and 8519** allow for a detailed and thorough evaluation of various steel protective coatings. The defect definitions allow for the evaluation of the protective system itself regardless of the condition of the element it protects.
- **Element 8519** – Duplex Systems refers to steel that has first been galvanized then painted over.
- **Defect 3430** - Element 8517 will only be evaluated by the defect Oxide Film Degradation/Color/Texture Adherence (3430).
- **Defect 3440** - Elements 515, 8516, 8518, and 8519 will only be evaluated by the defect Effectiveness (3440).

Defect	CS 1	CS 2	CS 3	CS 4
	Good	Fair	Poor	Severe
Oxide Film Degradation/ Color/ Texture Adherence – Weathering Steel (3430)	Yellow-orange or light brown for early development. Chocolate-brown to purple-brown for fully developed. Tightly adhered, capable of withstanding hammering or vigorous wire brushing.	Granular texture.	Small flakes, less than 1/2 in. diameter.	Dark black color. Large flakes, 1/2 in. diameter or greater or laminar sheets or nodules.
Effectiveness (3440)	Fully effective.	Substantially effective.	Limited effectiveness.	Failed, no protection of underlying metal.

Descriptions:

Fully Effective: Coating system may have minor fading, chalking, dulling, but there is no corrosion and primer coat is intact.

Substantially Effective: Coating system may have moderate deterioration such as chalking, peeling, blistering or cracking to finish coat. Surface/freckle rust or staining may be present, but there is no pack rust.

Limited Effectiveness: Coating system has extensive deterioration to finish and primer coats. Surface rust is prevalent. Pack rust may be present.

Severe/Failed: Coating system is failed or non-existent providing no protection to the underlying metal. There may be heavy corrosion and pack rust.

Condition State 2

Condition State 3

Condition State 4

Oxide Film Degradation/ Texture Adherence (3430)

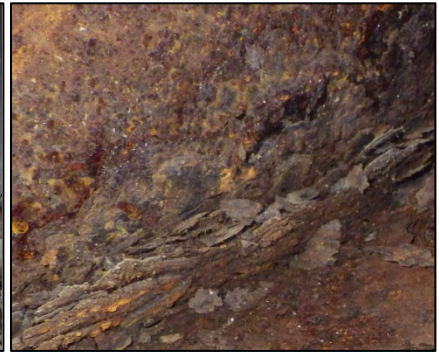

Effectiveness (3440)



Chapter 3.J – Wearing Surfaces

J. Wearing Surfaces



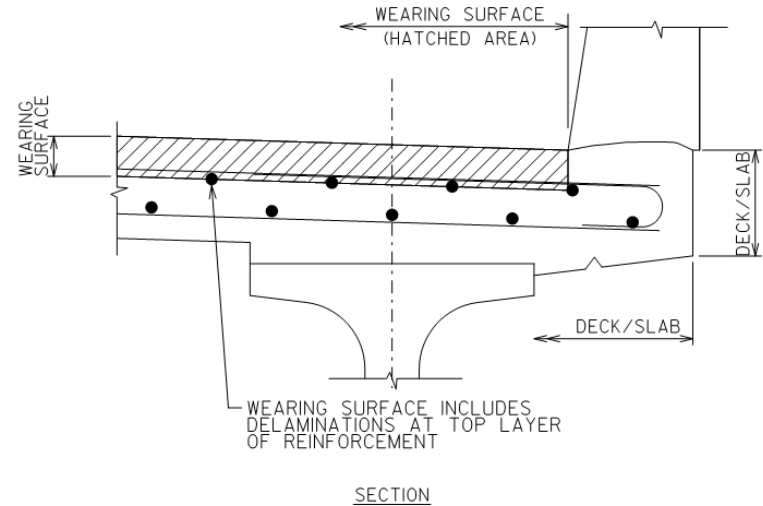

Wearing Surfaces	
510 – Wearing Surfaces (Other)	SF
8000 – Wearing Surface (Bare)	SF
8511 – AC Overlay	SF
8512 – AC Overlay & Membrane	SF
8513 – Thin Polymer Overlay	SF
8514 – Concrete Overlay	SF
8515 – Polyester Concrete Overlay	SF

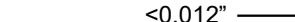
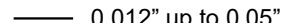

Narrative:

- Gravel/Debris covered decks/slabs should be cleared in order to allow visual inspection of the wearing surface.
- An asphalt patch on a concrete wearing surface is not a sound patch.
- When Infrared (IR) or Ground Penetrating Radar (GPR) results are available for wearing surfaces, the inspector should incorporate the data into the applicable condition states. For example, 10% delaminations/debonding noted on the IR results, 10% should be coded under the applicable wearing surface element condition state for delaminations/debonding.
- The quantity for general wearing surfaces should include the area of the deck/slab from inside face of parapet face to inside face of parapet (including at grade sidewalks or multi-use paths separated by a traffic barrier, but excluding raised sidewalks, traffic barrier(s) and medians) and be measured in square feet.
- **Element 510** - Timber or steel running boards will be coded under Element 510 - Wearing Surfaces (Other).
- **Element 8000** - The top of the deck/slab will be evaluated with the respective wearing surface. Decks/slab without a wearing surface will have the top of the deck/slab evaluated under Element 8000 – Wearing Surface (Bare).

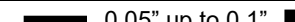
- **Element 8000** - shall not be used for Element 28 – Steel Deck with Open Grid. Element 28 shall be evaluated based on top, sides and bottom of element.
- **Element 8000** - shall not be used with Elements 29 or 30. Elements 29 and 30 shall be accompanied with the appropriate filling material that was used on the deck. Elements 29 and 30 shall be evaluated based on sides and bottom of element only.
- **Element 8511** - Chip Seals will be coded under Element 8511 – AC Overlay.
- **Element 8512** - Polymer Modified Asphalt (PMA) systems will be coded under Element 8512 – AC Overlay & Membrane.
- **Defect 3120** - IR/Thermography or GPR Results for delaminations down to the top layer of reinforcement should be quantified under Defect 3210 under the applicable wearing surface element.
- **Defect 3210** – Code all chert pop-outs as condition state 1 under defect 3210 and Include notes describing extent of pop-outs.
- **Defect 8911** - Abrasion is the removal of cement paste and/or surface aggregate and can occur in the flow line on top of the bridge decks. It will be noted at the extreme edge of deck surface. Plow abrasions on decks can be considered along with the abrasion defect.
- **Defect 8911** - Wear is the removal of deck surface aggregate by repeated vehicular traffic.
- **Defect 8912** – Only used for Steel Decks.
- **Assessment 9325** - Wearing surface elements are not to be used in conjunction with Assessment 9325 – Roadway Over Structure.

Concrete Cracks				Concrete Scale/Abrasion/Wear	
Crack Widths		Crack Density or Spacing			
Hairline	<0.012" 	Minor	>3 feet	Light Scale	<¼" Deep
Narrow	 0.012" up to 0.05" 	Moderate	1 to 3 feet	Medium Scale	¼" up to ½" Deep
Medium	 0.05" up to 0.1" 	Extensive	<1 foot	Heavy Scale	½" to 1" Deep
Wide	 >0.1"			Severe Scale	Loss of aggregate

Chapter 3.J – Wearing Surfaces

Defect	CS 1	CS 2	CS 3	CS 4
	Good	Fair	Poor	Severe
Wearing Surfaces				
Debonding/Delaminations/ Spalls/Patched Area/Pothole – Wearing Surface (3210)	None.	Delaminated. Spall 1 in. or less deep or less than 6 in. in diameter. Patched area that is sound.	Spalls greater than 1 in. deep or greater than 6 in. in diameter. Patched areas that are unsound or showing distress.	The wearing surface area is no longer effective.
Crack – Wearing Surface (3220)	No cracks. Hairline cracks not requiring sealing, or cracks that have been sealed.	Unsealed cracks of narrow width, or unsealed minor to moderate pattern/map cracking.	Unsealed cracks of medium to wide width, or extensive patterns/map cracking.	
Agency Defined Defects				
Abrasion, Wear, Rutting, or Loss of Friction – Wearing Surface (8911)	None	Minimal loss of surface material in wheel paths. No significant loss of friction has occurred. Asphalt overlay exhibiting minor isolated rutting.	Loss of surface material has become prevalent in the wheel paths. Loss of friction is noticeable. Asphalt overlay has moderate to severe isolated rutting.	Loss of surface material is widespread throughout overlay. Loss of friction is prevalent and potentially dangerous in adverse weather conditions. Asphalt overlay has significant rutting throughout the length of structure.
Deterioration/Distortion – Wearing Surface (8912)	None	Minor corrosion, arrested cracks, or loose fasteners, but functioning as intended. Distortion not requiring mitigation or has been mitigated.	Section loss, cracks not arrested, or missing fasteners. Distortion that requires mitigation that has not been addressed. Condition does not warrant structural review.	Advanced section loss, cracks, or missing fasteners. Loose grating sections that could pose a safety hazard. Distortion that requires mitigation that has not been addressed.

Notes: Refer to Concrete Cracking Table on previous page for description of crack widths.

Condition State 2

Condition State 3

Condition State 4

Debonding/Spall/Patched Area/Potholes (3210)



Cracks, Concrete or Epoxy (3220)



Condition State 2



Condition State 3

Cracks, Asphalt (3220)



Condition State 4



Chapter 3.K – Reinforcing Steel Protective Coatings

K. Reinforcing Steel Protective Systems

Reinforcing Steel Protective Systems	
520 – Concrete Reinforcing Steel Protective System (Other)	SF
8522 – Coated Reinforcing	SF
8523 – Stainless Steel Reinforcing	SF
8524 – Non-metallic Reinforcing	SF

Narrative:

- For Information Purposes Only. Inspector will not code Condition States of these elements; simply the type used in the deck.
- Inspector **shall** select type of Reinforcing Steel Protective System under the deck element in HSIS.
- Reinforcing protective system is selected when coding the deck or slab element and is defaulted to the deck area. Inspector will not be able to change area.
- Existing plans should be verified to select proper reinforcing protective system.
- When type of reinforcing steel in the deck is unknown, the inspector should select black (uncoated) reinforcing steel.
- For hybrid decks (top mat of steel epoxy coated, bottom mat black), epoxy steel shall be selected under the deck type.

Chapter 3.L – Concrete Protective Coatings

L. Concrete Protective Coating

Concrete Protective Coatings	
521 – Concrete Protective Coating	SF

Narrative:

- Element currently not used by WisDOT

Defect	CS 1	CS 2	CS 3	CS 4
	Good	Fair	Poor	Severe
Concrete Protective Coatings				
Effectiveness – Concrete (3540)	Fully effective.	Substantially effective.	Limited effectiveness.	The protective system has failed or is no longer effective.

Chapter 3.M – Strengthening/Repair Systems

M. Strengthening/Repair Systems

Strengthening Systems	
8800 – FRP	EA
8801 – Jacketing	EA
8802 – Culvert Liner	LF
8803 – External Post Tensioning	EA

Narrative:

- **Element 8800** – FRP (Fiber-Reinforced Polymer) will consist of all repairs made to various structural members using FRP. Examples include girder reinforcement and column wraps. The quantity is for each member/element wrapped in FRP.
- **Element 8801** – Jacketing will consist of all jackets found on substructure units. Element shall be used for all materials except FRP. Examples include concrete jacket on timber column, steel jacket on concrete column, steel jacket on timber column, etc.
- **Element 8803** – External Post Tensioning will consist of steel post tensioning members installed as a retrofit after original construction to add strength to a member.
-
- **Defect 1130** - Refer to Concrete Cracking Table on Page 32 for description of crack widths for Defect 1130.

Defect	CS 1	CS 2	CS 3	CS 4
	Good	Fair	Poor	Severe
FRP and Culvert Liner Only				
Deterioration (1220)	None	Initiated breakdown or deterioration.	Significant deterioration or breakdown, but does not warrant a structural review.	The condition warrants a structural review to determine the effect on strength or serviceability of the element or bridge; OR a structural review has been completed and the defects impact strength or serviceability of the element or bridge.
Distortion (1900)	None	Distortion not requiring mitigation or mitigated distortion.	Distortion that requires mitigation that has not been addressed.	
Jacketing and External Post Tensioning Only				
Delaminations/Spalls/Patch Areas/Exposed Rebar (1080)	None	Delaminated. Spalls 1 in. or less deep or less than 6 in. diameter. Reinforcement may be exposed. Corrosion may be present, but without section loss. Patched area that is sound.	Spalls greater than 1 in. deep or greater than 6 in. diameter. Patched area that is unsound or showing distress. Reinforcement present with measurable section loss. Does not warrant structural review.	The condition warrants a structural review to determine the effect on strength or serviceability of the element or bridge; OR a structural review has been completed and the defects impact strength or serviceability of the element or bridge.
Cracking (RC) (1130)	No cracks. Hairline cracks not requiring sealing, or cracks that have been sealed.	Unsealed cracks of narrow width, or unsealed minor to moderate pattern/map cracking. Where efflorescence is present, it's minor with no evidence of rust staining.	Unsealed cracks of medium to wide width, or extensive pattern map cracking. Where efflorescence is present, there is heavy build-up and/or rust staining.	

Chapter 3.M – Strengthening/Repair Systems

Defect	CS 1	CS 2	CS 3	CS 4
	Good	Fair	Poor	Severe
Jacketing and External Post Tensioning Only				
Corrosion (1000)	None	Freckled rust. Corrosion of the steel has initiated.	Section loss is evident or pack rust is present but does not warrant structural review.	The condition warrants a structural review to determine the effect on strength or serviceability of the element or bridge; OR a structural review has been completed and the defects impact strength or serviceability of the element or bridge.
Cracking (Steel) (1010)	None	Crack that has self-arrested or has been arrested with effective arrest holes, doubling plates, or similar.	Identified crack exists that is not arrested but does not warrant structural review.	
Connection (1020)	Connection is in place and functioning as intended.	Loose fasteners or pack rust without distortion is present but the connection is in place and functioning as intended.	Missing bolts, rivets, broken welds, fasteners or pack rust with distortion but does not warrant a structural review.	
Cracking (PSC) (1110)	Width less than 0.004 in. or spacing greater than 3 ft. Without efflorescence.	Width 0.004 – 0.009 in. Where efflorescence is present, it's minor and no evidence of rust staining.	Width greater than 0.009 in. Where efflorescence is present, there is heavy build-up and/or rust staining.	
Abrasion/Wear (PSC/RC) (1190)	No abrasion.	Abrasion has exposed coarse aggregate but the aggregate remains secure in the concrete.	Coarse aggregate is loose or has popped out of the concrete matrix due to abrasion.	

Chapter 4 – Assessments

Chapter 4. Assessments

- **Drainage – Structure Approach (9001):** Record drainage issues at the approaches to the structure resulting from deck and roadway runoff - include slopes/drainage around the ends of the wings and all drainage features within 20 feet of wingtip - flumes, inlets, catch basins, curb/gutter, etc. Typically 1 EA per quadrant. Will not be coded on Unit Bridges.
- **Drainage (9004):** Quantity is the total of all drainage systems located on the deck or along retaining walls. Retaining walls include drainage along the top of the wall and in front of the wall.
- **Median (9007):** If median is longitudinally split, total quantity is 1 EA. Do not double the quantity.
- **Sidewalk (9009):** Use when raised from deck and is greater than 18 inches wide. Raised sidewalk located on a structural approach slab(s) shall be coded as sidewalk assessment 9009. Quantity 1 EA per line of sidewalk including structural approaches when present.
- **Utilities (9011):** Utilities are allowed on bridges with a signed permit by the Maintaining Authority. The utility is required to adjust, repair or restore their attachments if it is found that they are not being maintained properly. The Maintaining Authority should notify the Utility if deficiencies exist and request they be corrected.
- **Slope Protection Assessments (9040-9047):** Slope settlements should be coded under the applicable slope protection assessment, and should not be coded under the element scour defect unless a significant scour event has occurred to wash out the slope paving.
- **Concrete Diaphragm (9168):**
 - Full depth diaphragms above a pier are considered a diaphragm and coded as Assessment 9168.
 - Partial height diaphragms (> half the height of the girder/beam web) are considered diaphragms and coded as Assessment 9168. Concrete protrusions less than half the height of the girder/beam web are considered part of the deck.
 - Full height concrete diaphragms that encase the girder/beam ends and retain fill are considered part of the abutment and should be coded as the applicable abutment element.
- **Lateral Bracing (9169):** Shall be used for the horizontal bracing inside of trapezoidal box girders and for the bracing on the underside of a deck for trusses. Quantity should be 1 EA per tub line, regardless of the number of spans. Includes lower lateral bracing members, not sway bracing or upper lateral/portal bracing on truss bridges. For trusses, quantity is 1 EA per span.
- **Approach Roadway Concrete (Non-Structural) (9322):**
 - For a non-structural approach overlaid with asphalt, the inspector will not code the overlay, but would only code the underlying approach slab.
 - Pavement relief joints will be assessed with Assessment 9322.
- **Roadway Over Structure (9325):** Used when there is more than 9" of fill over the culvert or deck slab. Wearing surface elements are not to be used in conjunction with this assessment.

Assessments	Qty.	Description	Good	Fair	Poor	Severe
Drainage – Structure Approach (9001)	EA	This defines drainage for the approach sections of the structure.	Drainage systems are functioning properly. No slope erosion is evident off the ends of the structure or in the associated ditches.	Minor erosion of slopes around the structure. Drainage systems are partially plugged or have minor deterioration.	Moderate erosion of slopes around the structure. Drainage systems are plugged or have moderate deterioration.	Major erosion of structure slopes not related to slope protection. Drainage systems are plugged and have major deterioration.
Drainage (9004)	EA	This defines drainage systems for the bridge deck, retaining wall, etc.	Drainage systems are functioning properly.	Drainage systems are partially plugged or have minor deterioration.	Drainage systems are plugged or have moderate deterioration.	Drainage systems are plugged and have major deterioration.
Median (9007)	EA	Use for medians. Do not use for curbs in medians with adjacent railing as the definition for these are contained in the railing.	No deterioration of median. Minor cracking.	Superficial spalls and/or narrow cracking.	Moderate deterioration such as medium to wide cracking, spalling, delaminations, etc.	Major deterioration. Reinforcement is exposed and major spalls throughout.

Chapter 4 – Assessments

Assessments	Qty.	Description	Good	Fair	Poor	Severe
Sidewalk (9009)	EA	Use for sidewalks on bridge decks greater than 18" wide. Do not use for curbs, as the definition for these are contained in the railing.	No deterioration of sidewalk. Minor cracking.	Superficial spalls and/or narrow cracking.	Moderate deterioration such as medium to wide cracking, spalling, delaminations, etc.	Major deterioration. Reinforcement is exposed and major spalls throughout.
Aesthetic Treatments (9010)	EA	Defines the condition of the aesthetic coating or treatment on a bridge structure. One each per bridge with aesthetic treatments.	System is in good condition, with no notable issues.	Aesthetic system is in fair condition, with some fading or discoloration. Minor issues.	Aesthetic system is in poor condition, with fading or discoloration.	Aesthetic system is in severe condition and is not functioning as intended.
Utilities (9011)	EA	Defines utilities that are attached to bridge structures. One each per utility system. Includes under deck lighting. Conduit cast in parapet and sidewalk are not included.	Utility is in excellent condition, no problems noted.	Utility is in fair condition. Some minor problems are noted, but they do not affect the serviceability of the utility.	Utility is in poor condition and local failures are possible.	Utility is in severe condition. Failures have occurred.

Assessments	Qty.	Description	Good	Fair	Poor	Severe
Movable Bridge – Counterweight (9020)	EA	Defines the condition of the counterweight system used for movable bridges.	Counterweight is in excellent condition, no problems noted.	Counterweight is in fair condition. Some minor problems are noted, but they do not affect the serviceability of the bridge.	Counterweight is in poor condition and local failures are possible. Serviceability of the bridge could be affected by the items continued deterioration.	Counterweight is in severe condition and is not functioning properly.
Movable Bridge – Cables (9021)	EA	Defines the condition of the cables on a movable bridge.	Cables are in good condition and are properly functioning.	Cables are in fair condition and are properly functioning.	Cables are in poor condition.	Cables are in severe condition, resulting in the lifting mechanism not working properly.
Signs - Object Markers (9030)	EA	Defines the condition of bridge object markers.	Sign is present and is in good condition (there may be superficial damage or deterioration).	Sign is present - sign may have some damage or deterioration (slightly bent or fading), but remains readable.	Sign is present, but is deteriorated to the point that replacement or repair should be considered in next inspection cycle.	Sign is absent, or incorrect, or existing sign is damaged or deteriorated to the extent that repair or replacement is required as soon as possible.
Signs - Narrow Bridge (9031)	EA	Defines the condition of Narrow Bridge Signs on a Narrow Structure.	Sign is present and is in good condition (there may be superficial damage or deterioration).	Sign is present - sign may have some damage or deterioration (slightly bent or fading), but remains readable.	Sign is present, but is deteriorated to the point that replacement or repair should be considered in next inspection cycle.	Sign is absent, or incorrect, or existing sign is damaged or deteriorated to the extent that repair or replacement is required as soon as possible.

Chapter 4 – Assessments

Assessments	Qty.	Description	Good	Fair	Poor	Severe
Signs - One Lane Bridge (9032)	EA	Defines the condition of One Lane Bridge signs on a One Lane Bridge.	Sign is present and is in good condition (there may be superficial damage or deterioration).	Sign is present - sign may have some damage or deterioration (slightly bent or fading), but remains readable.	Sign is present, but is deteriorated to the point that replacement or repair should be considered in next inspection cycle.	Sign is absent, or incorrect, or existing sign is damaged or deteriorated to the extent that repair or replacement is required as soon as possible.
Signs - Vertical Clearance (9033)	EA	Defines all vertical clearance signs (both near bridge and advanced warning).	Sign is present and is in good condition (there may be superficial damage or deterioration).	Sign is present - sign may have some damage or deterioration (slightly bent or fading), but remains readable.	Sign is present, but is deteriorated to the point that replacement or repair should be considered in next inspection cycle.	Sign is absent, or incorrect, or existing sign is damaged or deteriorated to the extent that repair or replacement is required as soon as possible.
Signs - Weight Limit Posting (9034)	EA	Defines all weight limit posting signs (both near bridge and advanced warning). Do not use if bridge is not load posted.	Sign is present and is in good condition (there may be superficial damage or deterioration).	Sign is present - sign may have some damage or deterioration (slightly bent or fading), but remains readable.	Sign is present, but is deteriorated to the point that replacement or repair should be considered in next inspection cycle.	Sign is absent, or incorrect, or existing sign is damaged or deteriorated to the extent that repair or replacement is required as soon as possible.

Assessments	Qty.	Description	Good	Fair	Poor	Severe
Signs – Other (9035)	EA	Can be used to define signage on bridge other than what is listed in specific sign assessment language.	Sign is present and is in good condition (there may be superficial damage or deterioration).	Sign is present - sign may have some damage or deterioration (slightly bent or fading), but remains readable.	Sign is present, but is deteriorated to the point that replacement or repair should be considered in next inspection cycle.	Sign is absent, or incorrect, or existing sign is damaged or deteriorated to the extent that repair or replacement is required as soon as possible.
Bridge Closure System (9036)	EA	This assessment defines the barricades, signs, and warning lights used to close a bridge structure from vehicular and/or pedestrian traffic. Quantity is one each per end of the bridge (2 total).	Signs and barricades are in place, in good condition, and functioning properly.	Signs and barricades are present and functioning as intended. Signs may have some damage or deterioration (slightly bent or fading, etc.), but remain readable. Barricades may have superficial damage, but are performing the intended function.	Signs and barricades are present, but they are deteriorated or compromised to the point that replacement or repair should be considered in next inspection cycle.	Signs or barricades are absent, or incorrectly placed such that they could pose a danger to the traveling public. Repair or replacement is required as soon as possible.
Slope Prot. - Asphaltic (9040)	EA	Defines slopes protected by asphaltic systems.	Slope protection is sound and protecting the embankments adjacent to the abutments.	Minor deterioration. Minor settlement, cracking or spalling may exist.	Moderate deterioration. Moderate settlement, cracking or spalling may exist.	Major deterioration of slope paving. Serious settlement, undermining, cracking, buckling or spalling may exist.

Chapter 4 – Assessments

Assessments	Qty.	Description	Good	Fair	Poor	Severe
Slope Prot. - Bare (9041)	EA	Defines slopes that have no protection systems.	Bare Slope is sound with no erosion present.	Minor erosion present.	Moderate erosion present.	Severe erosion is present.
Slope Prot. - Concrete (9042)	EA	Defines slopes protected by concrete.	Concrete slope protection is sound and protecting the embankments adjacent to the abutments.	Minor deterioration. Minor settlement, cracking or spalling may exist.	Moderate deterioration. Moderate settlement, cracking or spalling may exist.	Major deterioration of slope paving. Serious settlement, undermining, cracking, buckling or spalling may exist.
Slope Prot. - Crushed Aggregate Sprayed w/ Bit. (9043)	EA	Defines slopes protected by crushed aggregate sprayed w/ Bit.	Crushed aggregate is sound and protecting the embankment adjacent to the abutments.	Minor deterioration. Slope may have settled. Loose surface aggregate due to bleaching. Portions may be missing.	Moderate deterioration. Slope has settled. Loose surface aggregate due to bleaching. Portions may be missing.	Major deterioration. Major settlement and/or buckling is evident.
Slope Prot. - Epoxy coated Crushed Agg (9044)	EA	Defines slopes that are protected by Epoxy Coated Aggregate Slope Paving.	Crushed stone is sound and protecting the embankment adjacent to the abutments.	Minor deterioration. Slope may have settled. Loose surface stone due to bleaching. Portions may be missing.	Moderate deterioration. Slope has settled. Loose surface stone due to bleaching. Portions may be missing.	Major deterioration. Major settlement is evident.

Assessments	Qty.	Description	Good	Fair	Poor	Severe
Slope Prot. – Riprap (9045)	EA	Defines slopes protected by riprap.	Riprap is adequate, sound and protecting the embankments adjacent to the abutments.	Minor deterioration. Slope may have settled and portions may be missing. Riprap provides some embankment protection.	Moderate deterioration. Slope may have settled and portions may be missing. Riprap provides little embankment protection.	Major deterioration. Slope has settled and portions are missing. Riprap provides no embankment protection.
Slope Prot. - Select Crushed Material (9046)	EA	Defines slopes protected by select crushed material.	Crushed aggregate is sound and protecting the embankment adjacent to the abutments.	Minor deterioration. Slope may have settled. Portions may be missing.	Moderate deterioration. Slope has settled. Portions may be missing.	Major deterioration. Major settlement is evident.
Slope Prot. – Other (9047)	EA	Defines other slopes not included in the specific slope protection definitions.	Slope is sound with no erosion present.	Minor deterioration, but functioning effectively.	Moderate deterioration and/or erosion.	Slope protection system has failed.
Steel Diaphragm (9167)	EA	Steel diaphragm members between girders.	Good condition. Connections are in place and functioning. No distortion.	Corrosion of the steel has initiated. Loose fasteners without distortion is present but the connection is functioning.	Section loss is evident or pack rust is present. Missing bolts, rivets, broken welds, or fasteners. Distortion is evident.	The system no longer functions as intended.

Chapter 4 – Assessments

Assessments	Qty.	Description	Good	Fair	Poor	Severe
Concrete Diaphragm (9168)	EA	Reinforced concrete diaphragms.	No deterioration. Possible discoloration, efflorescence, or superficial cracking but doesn't affect strength or serviceability.	Minor cracks and spalls may be present but there is no exposed reinforcing or surface evidence of rebar corrosion.	Some delaminations &/or spalls may be present and some reinforcing may be exposed. Possible rebar corrosion but section loss is incidental and doesn't significantly affect strength or serviceability.	Advanced deterioration. Corrosion of reinforcement &/or loss of concrete section is sufficient to warrant analysis to ascertain the impact on the strength &/or serviceability of either the element or the bridge.
Lateral Bracing (9169)	EA	Lateral Bracing Systems Through trusses/arches (underside of deck), deck trusses, and inside of trapezoidal box girders. 1 EA per span for trusses and 1 EA per box girder line.	Good condition. Connections are in place and functioning. No distortion.	Freckled Rust. Corrosion of the steel has initiated. Loose fasteners or pack rust without distortion is present but the connection is functioning.	Section loss is evident or pack rust is present. Missing bolts, rivets, broken welds, or fasteners.	The system no longer functions as intended.
Truss or Tied/Arch Portal Bracing (9170)	EA	Bracing system used above the roadway. Includes portals, lateral and sway bracing. Includes secondary gusset plates. 1 EA per span.	Good condition. Connections are in place and functioning. No distortion.	Corrosion of the steel has initiated. Loose fasteners may be present but the connection is functioning. No impact damage noted.	Section loss is evident or pack rust is present. Missing bolts, rivets, broken welds, or fasteners. Impact damage may be present, but has not distorted primary truss members.	The system no longer functions as intended. Impact damage has distorted primary truss members.

Assessments	Qty.	Description	Good	Fair	Poor	Severe
Timber Diaphragm (9171)	EA	Timber diaphragm members between beams.	Minor timber deficiencies are present. Connections are in place and functioning as intended.	Moderate timber deficiencies present, but secure. Loose fasteners are present but the connection is functioning.	Advance timber deficiencies present, including splitting and minor rot. Missing bolts, rivets, broken welds, or fasteners.	The system is rotted, missing, or no longer functions as intended.
Culvert End Treatment (9248)	EA	This element applies to culvert headwalls, aprons or other end treatments (any material). The quantity is expressed as an "each" item - on a typical culvert, the quantity will be "2" (one for each end). Wingwalls are not covered by this assessment.	Culvert end treatment has little or no deterioration. Timber may have minor splitting. Steel may have minor surface corrosion. Masonry may have minor weathering (mortar joints are sound). Concrete may have minor cracking or scale.	Culvert end treatment has minor to moderate deterioration. Timber may have moderate splitting (minor decay or fire damage). Steel may have moderate surface corrosion (minor section loss). Masonry may have moderate weathering (mortar joints may have minor deterioration). Concrete may have moderate cracking or scaling (there may be minor delamination or spalling). End treatment may have slight undermining, settlement, misalignment, or separation.	Culvert end treatment has extensive deterioration. Timber may have extensive splitting - there may be significant decay or fire damage (slight sagging or crushing). Steel may have extensive corrosion (measurable section loss). Masonry may have extensive weathering (mortar joints may have significant deterioration). Concrete may have extensive cracking or scaling (delamination or spalling may be prevalent). End treatment may have significant undermining, settlement, misalignment, or separation.	Culvert end treatment has severe deterioration, the function or structural capacity of the culvert has been severely impacted - immediate repairs or structural analysis may be required. Timber may have severe splitting or advanced decay (severe sagging or crushing). Steel may have advanced corrosion (severe section loss). Masonry may have severe weathering (mortar joints may have failed). Concrete may have severe cracking, scaling, delamination, or spalling. End treatment may have severe undermining, settlement, misalignment, or separation.

Chapter 4 – Assessments

Assessments	Qty.	Description	Good	Fair	Poor	Severe
Crash Walls/ Web Walls/ Cross Bracing or Struts (9250)	EA	Defines all types of cross bracing systems not defined by other elements. 1 EA per substructure unit.	No deterioration.	Minor deterioration is present but does not affect serviceability of the element.	Moderate deterioration is present but not of sufficient magnitude to affect serviceability of the bridge.	The system no longer functions as intended.
Dolphin or Fender System (9290)	EA	Defines systems used to protect bridge substructure units from vessel collisions.	The dolphin or fender system has little to no deterioration. Minor wear and deterioration may be present but the system is functioning as intended.	The dolphin or fender system shows signs of deterioration or minor collision damage but the protection of the bridge has not been compromised.	The dolphin or fender system has advanced deterioration or significant collision damage that compromises its effectiveness in protecting the bridge.	The dolphin or fender system has failed and provides little to no protection for the bridge.
Approach Roadway - Concrete (Non- Structural) (9322)	EA	This defines approach roadway sections that are concrete but are not designed as a structural slab.	No deterioration or horizontal or vertical movement other than superficial surface cracks.	Minor cracks & spalls. There may be some settlement or heaving which increases traffic impact on bridge. <1/2" settlement.	Cracks may extend through slab, but doesn't act as if it is broken. Major spalls, but they do not affect the structural integrity of the slab. <1" settlement.	Slab is broken or rocks under traffic loads. Settlement >1" and cannot be corrected without increasing the size of the slab. Deterioration is excessive which no longer allows for mudjacking.

Assessments	Qty.	Description	Good	Fair	Poor	Severe
Approach Roadway – Asphalt (9323)	EA	This defines approach roadway sections that are composed of asphalt.	No deterioration or settlement other than superficial cracks.	Minor cracks. May be minor settlement which increases traffic impact on bridge. <1/2" settlement.	Alligator cracks and possible rutting is evident. Settlement may be occurring which increases traffic impact on bridge. <1" settlement.	Major rutting and cracks are evident. >1" settlement which increases traffic impact on the bridge.
Approach Roadway – Gravel (9324)	EA	This defines approach roadway sections that are composed of gravel.	No potholes or depressions near edge of bridge deck. Minimal gravel may have been pushed onto deck. Approaches provide smooth transition to bridge.	Minor potholes or depressions near edge of bridge deck or minor amounts of gravel pushed up on deck. Minor problems that are sufficient to create a noticeable traffic bump.	Moderate potholes or depressions less than 1 inch deep near edge of bridge deck or moderate amounts of gravel pushed up on deck. Minor problems that are sufficient to create a noticeable traffic bump.	Significant potholes or depressions greater than 1 inch deep near edge of bridge deck or significant amounts of gravel pushed onto deck. Problems that are substantial enough to launch vehicular traffic so that vehicles bounce on the bridge creating possible impact damage.
Roadway Over Structure (9325)	EA	This element defines the roadway over a buried culvert or arch where there is more than 9" of fill.	The roadway over structure is smooth and shows no sign of settlement.	The roadway over structure has minor settlement and roadway may be cracked and deteriorated.	The roadway over structure has moderate settlement and roadway may be cracked and deteriorated.	Roadway over structure has significant deterioration and settlement.

Chapter 4 – Assessments

Assessments	Qty.	Description	Good	Fair	Poor	Severe
Decorative Rail (9335)	EA	Non-structural decorative elements or pedestrian railing on top of bridge railing.	Rail has little or no deterioration. Galvanizing or protective coating is sound.	Rail has minor deterioration. Coating may have minor failure - surface rust may be present.	Rail has moderate deterioration. Coating may have moderate failure - surface rust may be prevalent. Components may be slightly bent or misaligned - connections may be slightly loose.	Rail has extensive deterioration. Coating may have extensive failure - there may be section loss. Components may be bent or misaligned - connections may be loose.
Luminaire Bases (9336)	EA	Defines the base unit of Luminaire supports typically located on traffic railing on the bridge.	Good condition, with no problems noted.	Fair condition, with superficial spalls and/or cracking.	Moderate deterioration, with cracking and spalls.	Base has failed. Major deterioration noted.
Protective Screening (9337)	EA	Protective screening or fencing on structures.	Screening or fencing has little or no deterioration. Protective coating is sound.	Screening or fencing has minor deterioration. Coating may have minor failure -. Fence components are properly aligned (all connections are sound).	Screening or fencing has moderate deterioration. Coating may have moderate failure -. Components may be slightly bent or misaligned - connections may be slightly loose. Fabric may have snags or holes (areas may be slightly stretched or deformed).	Screening or fencing has extensive deterioration. Coating may have extensive failure - there may be section loss. Components may be bent or misaligned - connections may be loose. Fabric may have numerous snags or holes (areas may be stretched or deformed).

Assessments	Qty.	Description	Good	Fair	Poor	Severe
Mechanical Ventilation Systems (9710)	EA	Defines ventilation systems attached within the structure.	System is in excellent condition, no problems noted.	Some minor problems are noted, but they do not affect the serviceability of the utility.	Local failures are noted. Connections to the tunnel wall may be heavily deteriorated.	System no longer functions as intended.
Drainage and Pumping Systems (9720)	EA	Defines the system to drain the tunnel or tunnel-like structure if flooded.	System is in excellent condition, no problems noted.	Some minor problems/clogs are noted, but they do not affect the serviceability of the utility.	Local failures are noted. Clogs are noted which restrict draining.	System no longer functions as intended. Clogs no longer allow system to drain water.
Electrical & Lighting Systems (9730)	EA	Defines the series progressive lighting system used to illuminate the tunnel/tunnel-like system. Includes backup generator.	System is in excellent condition, no problems noted.	Various luminaires may be burnt out, but they do not affect the serviceability of the utility.	Several luminaires in succession may be burnt out. Connections to the tunnel wall may be heavily deteriorated.	System not functioning as intended. Sections may be disconnected from the tunnel wall.
Fire Detection & Prevention Systems (9740)	EA	Defines the system used to identify and extinguish fires in tunnels and tunnel-like structures.	System is in excellent condition, no problems noted.	Some minor problems are noted, but they do not affect the serviceability of the utility.	Local failures are noted.	Failures have occurred.

THIS PAGE IS INTENTIONALLY BLANK

Chapter 5. National Bridge Elements

This section describes in detail those elements that are primary structural elements. Primary structural elements are those in the load path. Bracing, struts and diaphragms are not primary structural elements. Diaphragms are considered primary when the bridge girders are curved.

These elements are meant to remain consistent from agency to agency throughout the country. These elements will be reported to FHWA on a yearly basis.

Although Agency Defined Elements (ADE's) are not reported to FHWA, the Department created various ADE's, which will be structural in nature in order to capture those elements' conditions states. These ADE's will be defined in this section and will be noted as an 8000 series number.

A. Decks/Slabs

Deck/Slab Elements

Reinforced Concrete Deck (Element 12) - This element defines all reinforced concrete bridge decks regardless of the wearing surface or protection systems used.

Prestressed Concrete Deck (Element 13) - This element defines all prestressed concrete bridge decks regardless of the wearing surface or protection systems used.

Prestressed Concrete Top Flange (Element 15) - This element defines those bridge beam/girder top flanges that are exposed to traffic. This element defines all prestressed concrete bridge girder top flanges regardless of the wearing surface or protection systems used. These bridge types include tee-beams, bulb-tees, and girders that require traffic to ride on the top flange.

Reinforced Concrete Top Flange (Element 16) - This element defines those bridge beam/girder top flanges that are exposed to traffic. This element defines all reinforced concrete bridge girder top flanges regardless of the wearing surface or protection systems used. These bridge types include tee-beams, bulb-tees, and girders that require traffic to ride on the top flange. Historically Wisconsin has evaluated reinforced concrete deck girders (or tee-beams) utilizing the elements reinforced concrete deck and reinforced concrete open girder/beam and continues to utilize this convention over the use of reinforced concrete top flange.

Steel Deck with Open Grid (Element 28) - This element defines all open grid steel bridge decks with no fill.

Steel Deck with Concrete Filled Grid (Element 29) - This element defines steel bridge decks with concrete fill either in all of the openings or within the wheel tracks or partial depth fill.

Steel Deck with Corrugated/Orthotropic/Etc. (Element 30) - This element defines those bridge decks constructed of corrugated metal filled with Portland cement, asphaltic concrete, or other riding surfaces. Orthotropic steel decks are also included.

Timber Deck (Element 31) - This element defines all timber bridge decks regardless of the wearing surface or protection systems used.

Reinforced Concrete Slab (Element 38) - This element defines all reinforced concrete bridge slabs regardless of the wearing surface or protection systems used.'

Prestressed Concrete Slab (Element 8039) - This element defines all prestressed concrete solid or hollow slabs, as well as inverted T-beams that are used as bridge decks, regardless of wearing surface used.

Timber Slab (Element 54) - This element defines all timber bridge slabs regardless of the wearing surface or protection systems used.

Other Material Deck (Element 60) - This element defines all bridge decks constructed of other materials regardless of the wearing surface or protection systems used.

Other Material Slab (Element 65) - This element defines all bridge slabs constructed of other materials regardless of the wearing surface or protection systems used.

Deck/Slab Commentary

- The function of the deck is to transfer loads to the superstructure. However, on some bridges, the deck and superstructure act as one, referred to as a slab, which distributes the live loads directly to the substructure.
- The primary reinforcing steel runs transversely in a deck where the deck is supported by longitudinal elements (beams and girders).
- The primary reinforcing steel runs longitudinally in a slab where the slab is supported by transverse elements (piers and abutments and in some cases where deck is supported by floor beams).
- All deck or slab elements will be supplemented with one or more associated protection systems or wearing surface elements.
- Deck/Slab surfaces that are not visible for inspection shall be assessed based on the available visible surfaces.
- If both top and bottom surfaces are not visible, the condition shall be assessed based on destructive and nondestructive testing or indicators in the materials covering the surfaces.
- When the top surface of the deck/slab is exposed and no wearing surface is on the deck/slab, sidewalks, Element 8000 – Wearing Surface (Bare) will be coded.
- In “element comment” indicate which method was used to determine the condition state. (i.e.: Audible Inspection, Thermography, Ground Penetrating Radar, Material Sampling, etc.) When other than visual inspection.
- Repair areas are only considered distressed areas if the repair is a short-term maintenance action, such as asphalt patches, and therefore does not restore the structural integrity. Repair areas are considered a rehabilitation if they improve the structural integrity of the slab, and therefore can improve the rating after work has been completed. A properly rehabilitated area should not be considered as a distressed area until it deteriorates.

Deck/Slab Quantity Calculation

- The quantity should include the area of the deck from edge to edge including any median areas, flares, or ramps.
- Where no deck exists the quantity for Element 15 & 16 include the area of the top flange from edge to edge including any median areas and accounting for any flares or ramps. This quantity is for the top flange riding surface only. Girder web and bottom flange to be evaluated by the appropriate girder element.
- The deck/slab evaluation includes bottom surface and sides using the defined condition states.

B. Superstructure

- The basic purpose of the superstructure is to transfer loads from the deck across the span and to the substructure.
- The superstructure supports the deck or riding surface of the bridge, as well as the loads applied to the deck.
- Superstructure elements may be categorized by their function (truss members will transmit mainly axial loads; girders will transmit mainly shear and flexure, etc.).
- Loads may be transmitted through tension, compression, bending, or a combination of these three.
- These elements typically do not include bracing components such as diaphragms, laterals, and cross bracing.
- Prefabricated structures (CON/SPAN or similar) without a floor should be coded with the appropriate arch element. Prefabricated structures with a floor should be coded with the appropriate culvert element. In either case, prefabricated structures that retain fill to support the roadway shall use the appropriate Wall Element instead of Assessment 9248 - Culvert End Treatment. The wall element shall be quantified and evaluated from end of wingwall to end of wingwall regardless of skew or construction joints located along length.

Girders/Beams

Girder/Beam Elements

Steel Closed Web/Box Girder (Element 102) - This element defines all steel box girders or closed web girders, and is for all box girders regardless of protective system.

Prestressed Concrete Closed Web/Box Girder (Element 104) - This element defines all pre-tensioned or post-tensioned concrete closed web girders or box girders, and is for all box girders regardless of protective system.

Reinforced Concrete Closed Web/Box Girder (Element 105) - This element defines all reinforced concrete box girders or closed web girders, and is for all box girders regardless of protective system.

Other Material Closed Web/Box Girder (Element 106) - This element defines all other material box girders or closed web girders, and is for all other material box girders regardless of protective system.

Steel Open Girder/Beam (Element 107) - This element defines all steel open girders, and is for all girders regardless of protective system.

Prestressed Concrete Open Girder/Beam (Element 109) - This element defines pre-tensioned or post-tensioned concrete open web girders, and is for all girders regardless of protective system.

Reinforced Concrete Open Girder/Beam (Element 110) - This element defines mild steel reinforced concrete open web girders, and is for all girders regardless of protective system.

Timber Open Girder/Beam (Element 111) - This element defines all timber open girders, and is for all girders regardless of protection system.

Other Material Open Girder/Beam (Element 112) - This element defines all other material girders, and is for all girders regardless of protection system.

Girder/Beam Commentary

- Girders/beams are horizontal flexural members that are the main or primary support for the deck.
- A linear structural member designed to span from one support (pier/bent/abutment) to another, and transfer loads from the deck to the substructure.
- Girders and beams can be differentiated from one another based on configuration. Girders will typically have a built-up floor system, which will be comprised of floor beams and stringers. Beams will not have these additional floor systems members, but may use diaphragms for lateral stability.
- Condition evaluation for this element includes both web faces and top and bottom faces of each exposed flange.
- If the top flange of the girder/beam is cast into a concrete deck, this face will not be rated unless section loss readings are obtained via NDE methods.
- This element does not take into account the condition of the protective coating.

Girder/Beam Quantity Calculation

- The quantity should include the sum of the lengths of every girder/beam from end to end.
- The quantity will be the size of the defect rounding up to the nearest whole foot. The height/depth of the defect per linear foot of element does not factor into the quantity calculation, but may affect the condition state.
- For multi-celled box girder structures, the quantity will be the full length of the girder times the number of girders, regardless of how many cells are present within a single girder.

Stringers

Stringer Elements

Steel Stringer (Element 113) - This element defines steel members that support the deck in a stringer floor beam system, and is for all stringers regardless of protective system.

Prestressed Concrete Stringer (Element 115) - This element defines pre-tensioned or post-tensioned concrete members that support the deck in a stringer floor beam system, and is for all stringers regardless of protective system.

Reinforced Concrete Stringer (Element 116) - This element defines mild steel reinforced concrete members that support the deck in a stringer floor beam system, and is for all stringers regardless of protective system.

Timber Stringer (Element 117) - This element defines timber members that support the deck in a stringer floor beam system, and is for all stringers regardless of protective system.

Other Material Stringer (Element 118) - This element defines all other material stringers, and is for all stringers regardless of protection system.

Stringer Commentary

- Condition evaluation for this element includes both web faces and top and bottom faces of each exposed flange.
- If the top flange of the stringer is cast into a concrete deck, this face will not be rated unless section loss readings are obtained via NDE methods.
- This element does not take into account the condition of the protective coating.
- Stringers are longitudinal beams spanning between transverse floor beams and support bridge decks.
- Stringers can be continuous or simple configuration. The configuration can be noted by the placement of the stringers with respect to the floor beams.
 - Continuous stringers are placed on top of the floor beam and transfer the load of the deck into the floor beam.
 - Simple span stringers can be gusseted into the side or sit on top of the floor beams and share the load of the deck with the floor beams.

Stringer Quantity Calculation

- The quantity should include the sum of the lengths of every stringer from end to end.
- The quantity will be the size of the defect rounding up to the nearest whole foot. The height/depth of the defect per LF of element does not factor into the quantity calculation, but may affect the condition state.

Trusses/Arches

Truss/Arch Elements

Steel Truss (Element 120) - This element defines all steel truss elements, including all tension and compression members, and through and deck trusses. It is for all trusses regardless of protective system.

Timber Truss (Element 135) - This element defines all timber truss elements, including all tension and compression members for through and deck trusses. It is for all trusses regardless of protective system.

Other Material Truss (Element 136) - This element defines all other material truss elements, including all tension and compression members, and through and deck trusses. It is for all other material trusses regardless of protective system.

Steel Arch (Element 141) - This element defines steel arches regardless of type, and is for all arches regardless of protective system.

Other Material Arch (Element 142) - This element defines other material arches regardless of type, and is for all other material arches regardless of protective system.

Prestressed Concrete Arch (Element 143) - This element defines only pre-tensioned or post-tensioned concrete arches.

Reinforced Concrete Arch (Element 144) - This element defines only mild steel reinforced concrete arches, and is for all arches regardless of protective system.

Masonry Arch (Element 145) - This element defines masonry or stacked stone arches, and is for all arches regardless of protective system.

Timber Arch (Element 146) - This element defines only timber arches, and is for all arches regardless of protective system.

Truss/Arch Commentary

- Trusses are jointed structures made up of individual members primarily carrying axial loads arranged and connected in triangular patterns.
- All bracing above roadway, including vertical sway bracing and portals shall be coded as Assessment 9170 - Truss or Tied/Arch Portal Bracing. The lower lateral bracing will be coded as an Assessment 9169 – Lateral Bracing.
- Arches are curved structure elements primarily in compression that transfers vertical loads through inclined reactions to its end supports.
- Prior to inspection, the inspector should determine the location of each tension and compression member. More scrutiny should be used on tension members, especially in fracture critical situations.
- Typically, trusses/arches will be separated by denoting panel points along the bridge. These are the location where members (verticals and diagonals) meet at the bottom/top chord, starting at Panel Point 0 in line with stationing, or Agency convention. When noting defects, panel points can be used as a reference point for specifying specific locations of defects. For filled arches, the arch quantity shall be measured from spring line to spring line. The length below the spring line is considered substructure.

Truss/Arch Quantity Calculation

- The quantity of a truss should include the sum of all lengths of each truss panel measured longitudinal to the travel way.
- Due to the way quantities are calculated, a vertical's Condition State will typically be quantified as 1LF, regardless of the amount of deterioration. Supplementary notes will be required to specify specific defects in these instances.
 - Example: A vertical on a truss bridge was hit by a truck and is deformed. 1LF would be moved to a higher condition state, but additional commentary will be required to identify the defect.
- Spandrel columns will be rated with the arch, as they are considered integral with the arch.
- A filled arch shall be measured from spring line to spring line. The length below the spring line is considered substructure.
- An open arch shall be quantified by adding the sum of all of the lengths of each arch section measured longitudinally along the travelled way.
- Observed distress in arch diagonals, vertical members (including spandrel columns) and spandrel walls shall be reported as the projected length along the travelled way.

Floor Beams

Floor Beam Elements

Steel Floor Beam (Element 152) - This element defines only steel elements that typically support stringers, and is for all floor beams regardless of protective system.

Prestressed Concrete Floor Beam (Element 154) - This element defines only prestressed elements that typically support stringers, and is for all floor beams regardless of protective system.

Reinforced Concrete Floor Beam (Element 155) - This element defines mild steel reinforced concrete floor beams that typically support stringers, and is for all floor beams regardless of protective system.

Timber Floor Beam (Element 156) - This element defines only timber superstructure elements that typically support stringers, and is for all floor beams regardless of protective system.

Other Material Floor Beam (Element 157) - This element defines other material floor beams that typically support stringers, and is for all floor b

eams regardless of protective system.

Floor Beam Commentary

- Floor beams are primary members located transversely to the general bridge alignment.
- Condition evaluation for this element includes both web faces and top and bottom faces of each exposed flange.
- If the top flange of the floor beam is cast into a concrete deck, this face will not be rated unless section loss readings are obtained via NDE methods.
- This element does not take into account the condition of the protective coating.

Floor Beam Quantity Calculation

- The quantity should include the sum of the lengths of all floor beams measured from end to end.
- The quantity will be the size of the defect rounding up to the nearest whole foot. The height/depth of the defect does not factor into the quantity calculation, but may affect the condition state.

Miscellaneous Superstructure Elements

Miscellaneous Superstructure Elements

Steel Main Cables (Element 147) - This element defines all steel main suspension or cable stay cables not embedded in concrete. The suspender cables in a suspension bridge are evaluated under Element 148. Cable stay systems typically include a sheath that protects the cable bundles, which are grouted within each cable stay. It is for all cable groups regardless of protective systems.

Secondary Steel Cables (Element 148) - This element defines all steel suspender cables not embedded in concrete. It is for all individual or cable groups regardless of protective systems. Hanger cables on tied arch bridges are considered secondary cables.

Steel Pin and Pin & Hanger Assembly or both (Element 161) - This element defines steel pins and pin and hanger assemblies and is for all assemblies regardless of protective system.

Steel Gusset Plate (Element 162) - This member defines only those steel gusset plate(s) connections that are on the main truss/arch panel(s). These connections can be constructed with one or more plates that may be bolted, riveted, or welded. Both sides of a chord are equal to one gusset plate. Gusset plates within a bracing system (i.e. lateral bracing gusset plates) should not be evaluated here. This element is for all gusset plates regardless of protective systems.

Steel Tension Rods/ Post-Tensioned Cables (Element 8165) - Defines rods and/or post tensioned cables that are visible to be inspected. Tensioning rods will typically be located within a member and will not be accessible to the inspector unless the member was post-tensioned during construction.

Timber Spreader Beam (Element 8166) - Defines a transverse timber member used on timber slab bridges to distribute load across the slab evenly. WisDOT reports this element separately due to the effect on load capacity. Timber spreader beams must be tight to the slab to perform properly.

Other Primary Structural Members (Element 8170) - Defines other structural members not defined by previous elements. Differing types of structural bracing that don't fall into any other category could be used for this element as an example.

Miscellaneous Superstructure Commentary

- Timber Spreader Beam (Element 8166) can have a direct effect on load carrying capacity of the structure, making it important to capture as part of the Element Level inspection

Miscellaneous Superstructure Quantity Calculation

- The quantity should include the sum of the length (LF) of the main cables and total number (EA) of secondary cables.
- Element 161
 - Individual pins that link girders to a transverse girder will be counted individually.
 - Pin and hanger assemblies will be counted as each assembly (two pins and two hanger bars equal one assembly)
- Element 162 – Gusset Plate: Gusset plates will be measured as one per panel point, regardless of the number of plates used to comprise the connection.

THIS PAGE IS INTENTIONALLY LEFT BLANK

C. Substructure

- Typically the substructure includes all elements below the bearings.
- Substructure units function as both axially-loaded and bending members. These units resist both vertical and horizontal loads applied from the superstructure and roadway embankment.
- Element 207 – Steel Tower and Element 208 – Timber Trestle are quantified by the sum of the vertical heights of each tower/trestle per linear foot.
- Substructure elements are either quantified as each for piles and columns or linear feet as with piers, caps, abutments and culverts. When quantifying culverts, measure the distance along the length of the culvert (pipe, barrel or cell) and sum all of the lengths of pipes, barrels or cells to establish the total quantity.
- In addition to assessing the elements per the material defects specific to the substructure element, consideration should be given to the effects of scour, undermining and settlement on the various elements.
- Scour is the removal of material from the streambed or embankment as a result of the erosive action of stream flow. It is important for the inspector to recognize that there are four types of scour that can affect a bridge and channel. These are:
 - General scour – occurs whether there is a bridge crossing or not. It includes natural streambed movements and natural river lateral movements over time.
 - Contraction scour – caused by an increase in water flow velocity as a result of channel constriction. Building a bridge over a waterway will often cause this. Contraction scour will cause a lowering of the streambed across the entire channel width. Local scour – occurs around an obstruction within the waterway, such as a bridge pier or abutment. The obstructions cause water turbulence, which stirs up the streambed material and allows it to be removed. Local scour is more severe when substructures do not line up with the flow of the stream or when blunt shapes (squared off pier ends) are used instead of streamlined shapes (round or tapered pier ends).
 - Lateral bank scour – caused by stream meandering, channel widening or man-made channel changes. It affects abutments, wingwalls, and approach embankments.

Columns/Pier Walls

Column/Pier Wall Elements

Steel Column (Element 202) - This element is for all steel columns regardless of protective system.

Other Material Column (Element 203) - This element is for all other material columns regardless of protective system.

Prestressed Concrete Column (Element 204) - This element is for all prestressed concrete columns regardless of protective system.

Reinforced Concrete Column (Element 205) - This element is for all reinforced concrete columns regardless of protective system.

Timber Column (Element 206) - This element is for all timber columns regardless of protective system.

Steel Tower (Element 207) - This element defines steel built up or framed tower supports, and is for all towers regardless of protective system.

Timber Trestle (Element 208) - This element defines framed timber supports, and is for all timber trestles regardless of protective system.

Reinforced Concrete Pier Wall (Element 210) - This element defines reinforced concrete pier walls, and is for all pier walls regardless of protective systems.

Other Material Pier Wall (Element 211) - This element defines those pier walls constructed of other materials. This is for all pier walls regardless of protective systems.

Timber Pier Wall (Element 212) - This element defines those timber pier walls that include pile, timber sheet material, and filler. This is for all pier walls regardless of protective systems.

Masonry Pier Wall (Element 213) - This element defines those pier walls constructed of block or stone. The block or stone may be placed with or without mortar. This is for all pier walls regardless of protective systems.

Column/Pier Wall Commentary

- Columns are vertical members which can carry axial load, horizontal load, and bending and are used as substructure elements.
- Columns may be supported on footings or they may be constructed as drilled shafts.
- Column/Pier footings can be either spread footings or pile supported footings.
- Pier walls transmit the load from the superstructure or pier cap/columns to the footing.

Column/Pier Wall Quantity Calculation

- The columns quantity should include the total number of Columns.
- The pier wall quantity should include the sum of the horizontal lengths measured along the skew angles.
- Steel towers and timber trestles will be quantified by the sum of the vertical heights of each tower/trestle per linear foot.

Abutments/End Bents

Abutment/End Bent Elements

Reinforced Concrete Abutment (Element 215) - This element defines reinforced concrete abutments. This includes the material retaining the embankment and monolithic wingwalls and abutment extensions. This is for all reinforced concrete abutments regardless of protective systems.

Timber Abutment (Element 216) - This element defines timber abutments. This includes the sheet material retaining the embankment, integral wingwalls and abutment extensions. This is for all abutments regardless of protective systems.

Masonry Abutment (Element 217) - This element defines those abutments constructed of block or stone, including integral wingwalls and abutment extensions. The block or stone may be placed with or without mortar. This is for all abutments regardless of protective systems.

Other Material Abutments (Element 218) - This element defines other material abutment systems. This includes the sheet material retaining the embankment, and integral wingwalls and abutment extensions. This is for all abutments regardless of protective systems.

Steel Abutment (Element 219) - This element defines steel abutments. This includes the sheet material retaining the embankment, and monolithic wingwalls and abutment extensions. This is for all abutments regardless of protective systems.

Integral Wingwall (Element 8400) - This element defines the wingwalls integral with the abutment which extend past the bridge seat for parallel wingwalls, or at the skew point when the wingwalls are turned back.

Abutment/End Bent Commentary

- Abutments are at either end of the bridge and transfer loads from the superstructure to foundation and provides lateral support for the roadway approach embankment.
- Integral wingwalls will include all monolithic sections of the wingwall whether parallel to the abutment past the bridge seat, or from the skew point when the wingwalls are turned back.
- Steel and timber wingwalls are considered to be integral wingwalls even with the presence of a joint at the end of the abutment on flared wingwalls. Steel and timber wingwalls are considered monolithic up to the first construction joint from the start of the wing at abutment body. All other wingwalls that are not monolithic with the abutment or past the skewed wingwall stub will be considered retaining walls.

Abutment/End Bent Quantity Calculation

- The quantity should include the sum of the width of the abutments only from edge of bridge seat to edge of bridge seat, or from skew angle to skew angle.
- End Bents are pile supported caps, which support the bearings and superstructure. The end bent cap is quantified in linear feet while the piles are quantified as the number of piles. Only the piles that are visible are quantified. The material that is retaining the embankment material on an end bent is what determines the abutment material type.
- Each integral wingwall inspected will be quantified as one Each.

Piles/Caps/Footings

Pile/Cap/Footing Elements

Reinforced Concrete Pile Cap/Footing (Element 220) - This element defines reinforced concrete pile caps/footings that are visible for inspection. Pile caps/footings exposed from erosion or scour or visible during an underwater inspection are included in this element. The exposure may be intentional or caused by erosion or scour.

Steel Pile (Element 225) - This element defines steel piles that are visible for inspection

Prestressed Concrete Pile (Element 226) - This element defines prestressed concrete piles that are visible for inspection

Reinforced Concrete Pile (Element 227) - This element defines reinforced concrete piles that are visible for inspection.

Timber Pile (Element 228) - This element defines timber piles that are visible for inspection.

Other Material Pile (Element 229) - This element defines other material piles that are visible for inspection.

Steel Pier Cap (Element 231) - This element defines those steel pier caps that support girders and transfer load into piles or columns.

Prestressed Concrete Pier Cap (Element 233) - This element defines those prestressed concrete pier caps that support girders and transfer load into piles or columns.

Reinforced Concrete Pier Cap (Element 234) - This element defines those reinforced concrete pier caps that support girders and transfer load into piles or columns.

Timber Pier Cap (Element 235) - This element defines those timber pier caps that support girders that transfer load into piles or columns.

Other Material Pier Cap (Element 236) - This element defines other material pier caps that support girders that transfer load into piles or columns.

Pile/Cap/Footing Commentary

- Piles are typically precast concrete, timber or steel and are part of a pile bent. A pile bent consists of the pile cap and piles. Piles in a pile bent are not supported by footings.
- Footings are the enlarged, lower portion of a substructure, which distributes the structure load either to the earth through a spread footing or to supporting piles or drilled shafts.
- If an element is visible, it must be quantified accordingly.
- If the inspector finds a footing or portion of footing exposed, they must determine if the footing is a spread footing or pile supported. An exposed spread footing is a much more serious condition and must be addressed immediately. The element must also be coded.
- Piles exposed from erosion or scour, and piles visible during an underwater inspection are included in all pile elements. Only those exposed are to be assessed and quantified.
- All piles and caps should be inspected as the material they are regardless of protection system.
- Cast in Place (CIP) piles with steel shells will be coded under the steel element. If deterioration of the steel shell is noted, the inspector must determine if the concrete inside of the shell is reinforced or not. This will assist of the severity of the shell corrosion (whether or not the steel shell is sacrificial or not).

Pile/Cap/Footing Quantity Calculation

- The quantity for pier caps and pile caps/ footings is the sum of the cap lengths measured along the skew angle.
- The quantity for piles is the sum of the number of piles visible for inspection.
- Non-visible piles are not quantified.

Culverts

Culvert Elements

Steel Culvert (Element 240) - This element defines steel culverts, including arched, round, or elliptical pipes.

Reinforced Concrete Culvert (Element 241) - This element defines reinforced concrete culverts, including box, arched, round, or elliptical shapes.

Timber Culvert (Element 242) - This element defines all timber culverts.

Other Material Culvert (Element 243) - This element defines other material type culverts, including arches, round, or elliptical pipes. These culverts are not included in steel, concrete, or timber material types.

Masonry Culvert (Element 244) - This element defines masonry block or stone culverts.

Prestressed Concrete Culvert (Element 245) - This element defines all prestressed concrete culverts.

Culvert Commentary

- A culvert is primarily a hydraulic structure, must have a floor, and its main purpose is to transport water flow efficiently.
- A rigid culvert's load carrying capacity is primarily provided by the structural strength of the culvert, with little strength developed from the surrounding soil. Rigid culverts typically do not bend or deflect appreciably when loaded
- Flexible culverts have little structural bending strength without proper backfill. Flexible culverts depend on the backfill for support to resist bending and as a result proper interaction between the soil and structure is critical.
- The distortion defect is contingent on a number of factors such as site, wall thickness, fill depth, etc. The inspector shall use such factors to assess the proper condition state.
- Culverts are defined as structures that have a floor.

Culvert Quantity Calculation

- The quantity should include the flow line length of the barrel multiplied by the number of barrels, excluding the aprons and end treatments.
- A culvert that spans longer than 20 feet measured along the centerline of the roadway is considered a bridge for NBI reporting purposes.

D. Bearings

Bearing Elements

Elastomeric Bearing (Element 310) - This element defines only those bridge bearings that are constructed primarily of elastomers, with or without fabric or metal reinforcement.

Movable Bearing (Element 311) - This element defines only those bridge bearings which provide for both rotation and longitudinal movement by means of roller, rocker, or sliding mechanisms.

Fixed Bearing (Element 313) - This element defines only those bridge bearings that provide for rotation only (no longitudinal movement).

Pot Bearing (Element 314) - This element defines those high load bearings with confined elastomer. The bearing may be fixed against horizontal movement, guided to allow sliding in one direction, or floating to allow sliding in any direction.

Disc Bearing (Element 315) - This element defines those high load bearings with a hard plastic disk. This bearing may be fixed against horizontal movement, guided to allow movement in one direction, or floating to allow sliding in any direction.

Other Bearing (Element 316) - This element defines all other material bridge bearings regardless of translation or rotation constraints.

Bearing Commentary

- A bridge bearing is an element which provides an interface between the superstructure and substructure.
- Bridge bearings transmit all primary live loads from superstructure to substructure, permit longitudinal movement of the superstructure due to thermal expansion and contraction, and allow rotation due to dead and live load deflection.

Bearing Quantity Calculation

- The quantity should include the number of each type of bearing.

E. Bridge Rail

Bridge Rail Elements

Metal Bridge Railing (Element 330) - This element defines all types and shapes of metal bridge railing. Steel, aluminum, metal beam, rolled shapes, etc. will all be considered part of this element. Included in this element are the posts of metal, timber or concrete, blocking, and curb.

Reinforced Concrete Bridge Railing (Element 331) - This element defines all types and shapes of reinforced concrete bridge railing. All elements of the railing must be concrete.

Timber Bridge Railing (Element 332) - This element defines all types and shapes of timber bridge railing. Included in this element are the posts of timber, metal or concrete, blocking, and curb.

Other Material Bridge Railing (Element 333) - This element defines all types and shapes of bridge railing except those defined as metal, concrete, timber, or masonry.

Masonry Bridge Railing (Element 334) - This element defines all types and shapes of masonry block or stone bridge railing. All elements of the railing must be masonry block or stone.

Bridge Rail Commentary

- The function of bridge railing is to contain and smoothly redirect errant vehicles on the bridge.
- The number of rows of rail on a bridge is commonly two, one on each side of the traveled way. In some cases there may be more than two rows when the bridge has a center median, or protected pedestrian/bicycle lanes. Refer to the other bridge rail material elements (concrete, timber, masonry, other) for specific defects for assessing the condition of posts, blocking and curbs that may be constructed of materials other than metal.
- Concrete bridge railing will be defined as concrete and masonry $\geq 12"$. If the railing is $< 12"$, then it will be considered curb.
- All railings on top of concrete and masonry bridge railing will be considered an assessment.
- In some instances, a bridge rail may be made up of more than one material (i.e., steel pedestrian rail mounted on a concrete barrier). The most predominant crash approved material should be rated in these instances.
- Curb along the length of the railing will be coded as part of the railing and not with the deck.

Bridge Rail Quantity Calculation

- The quantity should include the number of barriers or railings times the length of the bridge, including any rails on integral wingwalls.
- Railings are measured along the edge from wingtip to wingtip of integral wingwalls.

THIS PAGE IS INTENTIONALLY LEFT BLANK

Chapter 6. Bridge Management Elements/Agency Defined Elements

- This section describes structure elements that agencies collect to support their Bridge Management System (BMS).
- Agency Defined Elements (ADE) described in this section will be defined as an 8000 series number.

A. Joints

Joint Elements

Strip Seal Expansion Joint (Element 300) - This element defines those expansion joint devices which utilize a neoprene type waterproof gland with some type of metal extrusion or other system to anchor the gland.

Pourable Joint Seal (Element 301) - This element defines those joints filled with a pourable seal with or without a backer.

Compression Joint Seal (Element 302) - This element defines only those joints filled with a preformed compression type seal. This joint may or may not have an anchor system to confine the seal.

Modular Joint (Element 303) - This element defines only those joints filled with an assembly mechanism that has a seal.

Open Expansion Joint (Element 304) - This element defines only those joints that are open and not sealed.

Assembly Joint without Seal (Element 305) - This element defines only those assembly joints that are open and not sealed. This includes finger and sliding plate joints.

Other Joint (Element 306) - This element defines only those other joints that are not defined by any other joint element.

B. Structural Approach Slabs

Structural Approach Slab Elements

Prestressed Concrete Structural Approach Slab (Element 320) - This element defines those structural sections, between the abutment and the approach pavement that are constructed of prestressed reinforced concrete.

Reinforced Concrete Structural Approach Slab (Element 321) - This element defines those structural sections, between the abutment and the approach pavement, that are constructed of mild steel reinforced concrete.

Structural Approach Slab Commentary

- Structural concrete approach slab surfaces that are not visible for inspection shall be assessed based on the available visible surface.
- If both top and bottom surfaces are not visible, the condition shall be assessed based on destructive and nondestructive testing or indicators in the materials covering the surfaces.
- Both Elements 320 and 321 are for structural approach slabs only. Non-structural approach slabs will be coded under the applicable Assessment.
- Structural approach slabs will have one end resting on the abutment paving notch, and the other end resting on a grade beam.

Structural Approach Slab Quantity Calculation

- The quantity should include the area of the slab from the adjacent bridge deck joint to the leading roadway, and from edge to edge including any median areas, flares, or ramps present.

C. Protective/Strengthening Systems

Protective/Strengthening System Elements

Steel Protective Coating (Element 515) - The element is for steel elements that have other protective coatings not listed below.

Painted Steel (Element 8516) - Paint systems applied to superstructure or substructure primary structural members.

Weathering Steel (Element 8517) - Protective system for steel.

Galvanization (Element 8518) - Galvanized protective systems.

Duplex Systems (Element 8519) – Protective system comprised of paint coating over galvanized coating.

Concrete Reinforcing Steel Protective System (Element 520) - This element defines other types of protective systems used to protect reinforcing steel in concrete elements from corrosion not listed below.

Coated Reinforcing (Element 8522) - Defines all types of coating systems (epoxy, galvanized, Zbar, etc.) over reinforcing steel. Place note in comments for element if the deck/slab has top mat only protection.

Stainless Steel Reinforcing (Element 8523) - Stainless steel reinforcement used in deck mats.

Non-Metallic Reinforcing (Element 8524) - Defines non-metallic systems (FRP, GFRP, etc.).

Concrete Protective Coating (Element 521) - This element is for concrete elements that have a protective coating applied to them. These coatings include silane/siloxane water proofers, crack sealers such as High Molecular Weight Methacrylate (HMWM), or any top coat barrier that protects concrete from deterioration and reinforcing steel from corrosion.

FRP (Element 8800) - This defines FRP (Fiber Reinforced Polymer) wrapped columns, pier caps, slabs, and beams.

Jacketing (Element 8801) - This defines jackets placed around columns, piles, etc. Assessment shall be used for all materials except FRP.

Culvert Liner (Element 8802) - This defines culverts with liners inserted for structural stability/strengthening.

External Post Tensioning (Element 8803) - This element defines the system used to strengthen structural member, such as a beam, column, cap, or footing by means of external post tensioning.

D. Wearing Surfaces

Wearing Surface Elements

Wearing Surfaces (Other) (Element 510) - This element is for all decks/slabs that have overlays other than those listed below, such as timber running planks.

Wearing Surface (Bare) (Element 8000) - This element defines decks/slabs that do not have a wearing surface and will be coded to capture the top of a deck/slab without a wearing surface.

AC Overlay (Element 8511) – Defines flexible asphaltic overlay.

AC Overlay & Membrane (Element 8512) - Defines flexible asphalt overlays with membranes or PMA systems.

Thin Polymer Overlay (Element 8513) - Defines thin polymer overlays.

Concrete Overlay (Element 8514) - Defines rigid concrete overlays.

Polyester Concrete Overlay (Element 8515) - Defines polyester concrete overlay systems.

Ancillary Structures – Sign/Signal/HML Elements

Chapter 7. Ancillary Structures

Ancillary structures are those assets within the highway right-of-way that are not specifically denoted as bridges defined by the National Bridge Inventory (NBI), but have a structural design. Ancillary structural assets include retaining walls (R), noise walls (N), high mast lights (L), sign and signal structures (S, G), and miscellaneous structures (M).

Elements and assessments under this section do not use stand-alone defects. The defect language is built right into the element/assessment.

Small Bridges (C) structures are handled in the Bridge section of the manual and won't be discussed in this section. Small Bridges (C) are treated the same as a normal bridge, but with a different inspection frequency requirement.

Sign/Signal/HML Elements

8701 – Base/Foundation	Signs, Signals, HML	EA
8702 – Steel Anchor Rods	Signs, Signals, HML	EA
8703 – Base Plate(s) (Aluminum or Steel)	Signs, Signals, HML	EA
8704 – Column Support(s) (Aluminum or Steel)	Signs, Signals, HML	EA
8705 – Truss Chord(s)/Mast Arm(s) (Aluminum or Steel)	Signs, Signals	LF
8706 – Connection – Column to Truss Chord/Arm	Signs, Signals	EA
8707 – Connection – Splices for Columns, Chords, Arms	Signs, Signals	EA
8708 – Overhead Sign Panels	Signs	EA
8709 – Signal Head(s)	Signals	EA
8710 – Connection – Overhead Sign Panel/Signal Heads	Signs, Signals	EA
8711 – Luminaire Arm, Head, and Connections	Signals	EA

Overall Sign/Signal/HML Ratings

Good (CS1): No, or very low deterioration observed in the sign, signal, or HML elements. Defects are minor, and within the normal range for newly constructed or fabricated elements. Highly functioning sign, signal, or HML element that is only beginning to show the first signs of distress or weathering.

Fair (CS2): Overall, the condition is satisfactory. Deficiencies are present in sign, signal, or HML elements, but do not compromise the overall function. Localized alignment issues, corrosion, deterioration, cracking, or missing hardware issues that are minor.

Poor (CS3): Overall condition is poor. Defects are present but does not pose an immediate threat to structural stability or serviceability. Moderate corrosion, cracking, deterioration, missing hardware or alignment issues that are significant but does not warrant a structural review. Repair and/or replacement is needed in the near future.

Severe (CS4): Critical condition. Major structural defects on components that have corrosion, loose bolts/rods, alignment issues, cracking, or damage that warrant structural review. Overhead signs and/or signals are illegible, not visible, damaged or missing.

Base/Foundation (Element 8701) - This element includes reinforced concrete foundations used for High Mast Lighting Structures, Overhead Signs, and Signal Monotubes. If a grout pad is present, it is also evaluated in this element. If Anchor Rod(s) were placed eccentrically, but the configuration has been approved by structural engineers, note that eccentricity in the notes with measurements for off-set.

Steel Anchor Rods (Element 8702) - This element defines anchor rods, anchor nuts, leveling nuts, and washers connecting the column support to the foundation. Quantity is per each rod.

Base Plate(s) (Aluminum or Steel) (Element 8703) - This element defines the base plates, flanges, casting clamps, gusset plates, seam welds, and welds at the connection of the column support to the foundation. Quantity is one each per base plate.

Column Support(s) (Aluminum or Steel) (Element 8704) - This element includes the vertical posts, diagonal members, and circumferential welds for the column support(s) on the structure. Quantity is one each per vertical column.

Truss Chord(s)/Mast Arm(s) (Aluminum or Steel) (Element 8705) - This element defines the chords of a truss system, or mast-arms. It also includes all diagonal members and struts integral to the truss. Total Quantity is length of truss or mast arm span, regardless of number of chords. (i.e. if Truss is 40' long, quantity is 40 LF regardless if 2, 3, or 4 chord truss).

Connection – Column to Truss Chord/Arm (Element 8706) - This element defines the flange and gusset plates connecting the span arms or chords to the column supports. Quantity is one each per connection location.

Connection – Splices for Columns, Chords, Arms (Element 8707) - This element defines the splice(s) used to connect members together. This includes the slip joint connections used in many pole applications. Quantity is one each per connection location.

Overhead Sign Panels (Element 8708) - This defines the overhead sign panel(s) of a sign structure. The rating shall include the legibility as well as condition of the panel(s). Quantity is one each per sign. Please indicate dimension(s) of the signs in notes for this element.

Signal Head(s) (Element 8709) - This defines the signal heads on a structure. Quantity is one each per signal head.

Connection – Overhead Sign Panel/Signal Heads (Element 8710) - This defines the L-brackets, vertical hangers, horizontal braces, U-bolts, sign panel connectors, sign connection clamps, banding, and other structural members that mount the sign panels to the structure. Quantity is one per vertical connection (e.g. Windbeam, Hanger, L-bracket, etc.)

Luminaire Arm, Head, and Connections (Element 8711) - This defines the connection, arm, and luminaire head on some signal and sign structures. Quantity is one each per assembly.

Name	Good	Fair	Poor	Severe
Base/ Foundation (8701)	The element shows no deterioration.	<p>Minor cracks and spalls may be present in the foundation, but only minimal reinforcing steel is exposed. When efflorescence is present, it is minor and no evidence of rust staining. Grout pad (if present) is in good condition.</p> <p>Minor erosion around foundation may be present, but does not affect structural capacity.</p>	<p>Many Spalls are present. Corrosion of reinforcement and/or loss of concrete section is evident though not sufficient to warrant structural analysis. Grout Pad (if present) has moderate cracking, spalls, or delaminations. Erosion may be present that reduces the foundation embedment significantly but does not pose a threat to the stability of the structure.</p>	<p>The condition warrants a structural review to determine the effect on strength or serviceability of the element, or a review has been completed and it has been found that the defects impact strength or serviceability.</p>
Steel Anchor Rods (8702)	The element shows no deterioration.	<p>Minor corrosion of the element is present, but the bolts appear to be properly tensioned and the nuts are fully engaged. Anchor rods may be slightly out of plumb (1:40 or less) without need for remediation, or out of plumb between 1:20 and 1:40 with proper beveled washers, and PE Stamped calculations on file to certify the configuration is ok.</p> <p>Anchor rod standoff exceeds current standards, but is within acceptable limits based on calculations.</p>	<p>Moderate corrosion of the elements may be present, but not enough to warrant structural analysis. Lock washers may be present. Anchor rod standoff exceeds current standards, and there is no analysis on file and rods appear to be performing adequately.</p>	<p>Severe Corrosion is present. Anchor rods are not properly tensioned; nuts may be missing or not fully engaged. Anchor rods are greater than 1:40 out of plumb w/o remediation (Greater than 1:20 requires immediate replacement). Anchor rod standoff exceeds current standards, and rod(s) show signs of bending, movement, buckling, or elongation. The condition warrants a structural review to determine the effect on strength or serviceability of the element, or a review has been completed and it has been found that the defects impact strength or serviceability.</p>

Name	Good	Fair	Poor	Severe
<p>Base Plate(s) (Aluminum or Steel) (8703)</p>	<p>The element shows no deterioration.</p>	<p>Minor corrosion of the element is present. No cracking of the element is observed. Casting clamp, if used, has no more than one horizontal bolt loose.</p>	<p>Moderate corrosion of the element is present. Cracks may be present on the base plate to column support connection weld, but have been arrested or is no longer active and do not affect the capacity of the plate. The base plate may be distorted (dished). Casting clamp, if used, has no more than two horizontal bolts loose.</p>	<p>Severe corrosion is present. Cracks may be present on the base plate to column support connection weld that have not been arrested. Section loss is significant and may affect the ultimate strength or serviceability of the element. Three or more horizontal casting clamp bolts are loose or missing, or cracks exist in the casting clamp assembly. The condition warrants a structural review to determine the effect on strength or serviceability of the element, or a review has been completed and it has been found that the defects impact strength or serviceability.</p>
<p>Column Support(s) (Aluminum or Steel) (8704)</p>	<p>The element shows no deterioration.</p>	<p>Minor corrosion is present. Standing water may be observed inside the post.</p>	<p>Moderate damage or corrosion is present, but does not warrant structural review. Cracks may be present on the pole, but have been arrested or are no longer active.</p>	<p>Heavy damage or corrosion of elements with section loss. Cracks may be present on the pole that have not been arrested. Elements may be misaligned or have severe impact damage that warrants structural analysis to ascertain the impact on strength or serviceability, or a review has been completed and it has been found that the defects impact strength or serviceability.</p>

Name	Good	Fair	Poor	Severe
<p>Truss Chord(s)/ Mast Arm(s) (Aluminum or Steel) (8705)</p>	<p>The element shows no deterioration.</p>	<p>Minor corrosion is present, but with no discernable section loss. Superficial damage to the element may exist.</p>	<p>Moderate damage or corrosion is present, but does not warrant structural review. Cracks may be present, but have been arrested or are no longer active.</p>	<p>Heavy damage or corrosion of elements with section loss. Cracks may be present that are active. Elements may be misaligned or have severe impact damage that warrants structural analysis to ascertain the impact on strength or serviceability, or a review has been completed and it has been found that the defects impact strength or serviceability.</p>
<p>Connection - Column to Truss Chord/Arm (8706)</p>	<p>The element shows no deterioration.</p>	<p>Minor corrosion is present, but with no discernable section loss. Superficial damage to the element may exist, as may minor misalignments. The connection is solid and is performing the intended function with no loss in capacity. Faying surface contact (0.01 in) is >75%.</p>	<p>Moderate damage, corrosion or misalignment is present, but does not warrant structural review. Faying surface contact (0.01 in) is between 50~75%. Connection is performing the intended function with no loss in capacity.</p>	<p>Heavy damage or corrosion of elements with section loss. Cracks may be present that are active. Faying surface contact (0.01 in) is less than 50%. Elements may be misaligned or have severe impact damage that warrants structural analysis to ascertain the impact on strength or serviceability, or a review has been completed and it has been found that the defects impact strength or serviceability.</p>

Chapter 7 – Ancillary Structures – Sign/Signal/HML Elements

Name	Good	Fair	Poor	Severe
Connection - Splices for Columns, Chords, Arms (8707)	The element shows no deterioration.	Minor corrosion is present, but with no discernable section loss. Superficial damage to the element may exist, as may minor misalignments. The connection is solid and is performing the intended function with no loss in capacity. Less than 5% of the connection bolts/fasteners are loose or missing. Faying surface contact (0.01 in) is >75%.	Moderate damage, corrosion or misalignment is present, but does not warrant structural review. Faying surface contact (0.01 in) is between 50~75%. 5~20% of the connection bolts/fasteners may be loose or missing, though the connection is performing the intended function.	Heavy damage or corrosion of elements with section loss. Cracks may be present that are active. Faying surface contact (0.01 in) is less than 50%. Greater than 20% of the connection bolts/fasteners are loose or missing. Elements may be misaligned or have severe impact damage that warrants structural analysis to ascertain the impact on strength or serviceability, or a review has been completed and it has been found that the defects impact strength or serviceability.
Overhead Sign Panels (8708)	The element(s) are present and show no deterioration. The sign is legible and up to current standards.	Minor loss of element legibility due to dulled paint or reflection. Minor deterioration may be present.	Moderate corrosion or damage may exist but not significantly affecting element legibility, nor stability.	Signs are illegible, or there is significant deterioration or damage to the sign panel that needs attention immediately.
Signal Head(s) (8709)	The element(s) are present and show no deterioration.	Minor deterioration and/or damage is present, but signal is still performing the intended function with no apparent loss in visibility.	Moderate deterioration or damage may be present. Signal head orientation is not in correct and should be adjusted. All bulbs appear to be functioning as intended.	Signal bulbs may be burned out, or orientation does not allow for signal to be used by traffic. There is sufficient damage to warrant analysis ASAP by Traffic Engineers.

Name	Good	Fair	Poor	Severe
Connection - Overhead Sign Panel / Signal Heads (8710)	The element(s) are present and show no deterioration.	Minor deterioration and/or minimal loose connections are present.	Moderate deterioration or damage may be present. Multiple connection components may not be fully functioning. Multiple loose/missing sign clips that could significantly affect the strength and/or serviceability.	Connection components may be cracked, sheared or missing. There is sufficient concern to warrant structural analysis to ascertain the impact on strength or serviceability, or a review has been completed and it has been found that the defects impact strength or serviceability.
Luminaire Arm, Head, and Connections (8711)	The element(s) are present and show no deterioration.	Minor deterioration and/or minor loose connections are present.	Moderate damage or corrosion is present, but does not warrant structural review. Cracks may be present, but have been arrested or are no longer active.	Connection components may be cracked, sheared or missing. There is sufficient concern to warrant structural analysis to ascertain the impact on strength or serviceability, or a review has been completed and it has been found that the defects impact strength or serviceability.

THIS PAGE IS INTENTIONALLY LEFT BLANK

Ancillary Structures - Wall Elements

Wall Elements

8600 – Cast in Place Concrete Wall	LF
8601 – Gabion Wall	LF
8602 – Gravity (Block & Rubble) Wall	LF
8603 – MSE Wall	LF
8604 – Post & Panel Wall	LF
8605 – Sheet Pile Wall	LF
8606 – Reinforced Soil Slope	LF
8607 – Secant or Tangent Shaft Walls	LF
8608 – Other Material Wall	LF
8609 – Noise Barrier/Wall – Ground Mounted	LF
8610 – Noise Barrier Wall – Structure Mounted	LF

Overall Wall Ratings

Good (CS1): No, or very low distress observed in the wall elements and assessments. Defects are minor, and within the normal range for newly constructed or fabricated elements. Highly functioning wall that is only beginning to show the first signs of distress or weathering.

Fair (CS2): Overall, the condition is satisfactory. Distress is present in wall elements and/or assessments, but does not compromise the wall function. Localized drainage issues, settlement, staining, washing of fines from backfill material that are minor.

Poor (CS3): Overall condition of the wall is poor. Distress is present, but does not pose an immediate threat to wall stability and closure of facilities adjacent to structure is not necessary. Repair and/or replacement is needed in the near future.

Severe (CS4): Critical condition. Major structural defects, or components have rotation, sliding, settlement, and/or overturning that is close to possible collapse. Wall is no longer serving the intended function, or is unstable and needs repair/replacement as soon as possible. Facilities adjacent to wall may need to be closed.

Narrative:

- Earth retention elements are designed to retain soil and can be made out of steel, concrete, timber, masonry/stone, and other materials. Typical defects associated with earth retention elements include scour and settlement as well as material defects.
- Primary causes of in-service wall failures include poor drainage, corrosion, facing deterioration, inadequate connection details, and latent construction defects.
- A noise barrier is a constructed appurtenance, either alone or integrated with other systems that alter the normal noise travel at a site.
- An inspector will not typically be able to inspect tie-backs or other types of anchorages that are located behind the wall for stabilization. Only the front face, top, and sides of a wall will typically be inspected during a normal inspection.
- Non-integral bridge wingwalls without 'R' numbers are considered retaining walls, and will be coded as part of the bridge inspection. Therefore, retaining wall elements will be used for these. Non-Integral wingwalls with 'R' numbers will not be coded as part of the bridge inspection; a separate ancillary wall inspection will be conducted.
- The quantity for wall elements is the length of the wall in lineal feet. All visible portions of the wall should be considered during inspection, including all coping at the top of the wall.
- When a noise barrier is present on a supporting bridge or retaining wall structure, and an inspection of that supporting structure is being conducted, the inspector shall perform a cursory inspection of the noise barrier as part of the bridge or retaining wall inspection. If any significant distress is observed, the owner of the noise barrier structure should be contacted.
- Tipping/Sliding/Settlement will be coded under the Wall Movement (8902) Defect.
- Material defects will be coded under the Material Deterioration (8903) Defect.
- Vertical or horizontal separation of individual wall components shall be captured with the Masonry or Panel Displacement (1640) Defect, including a comment on the inspection report noting fill spill-through, if present.

Wall Elements

CIP Concrete Wall (Element 8600) - Cast-in-place (CIP) concrete walls are made by placing ready-mix concrete into removable forms that are built around reinforcing steel at the final intended position of the wall. A concrete wall will have to be anchored and can incorporate tie-backs or prestressed soil anchors for stabilization depending on the height of the wall and characteristics of the soil that is being restrained.

Gabion Wall (Element 8601) - Gabion walls are constructed from rock-filled wire mesh baskets. The gabions typically have a heavy wire mesh with a nominal 3-inch opening and are formed into rectangular baskets, normally 1.5 to 3 feet in height.

Gravity (Block & Rubble) Wall (Element 8602) - A gravity wall is a large monolithic structure, which depends entirely on its self-weight and the weight of the soil that rests upon it for stability. The walls are typically constructed of concrete or masonry with very little, if any, steel reinforcement. Concrete gravity walls are typically less than 10 feet tall, and segmented modular block gravity walls are limited by design to an exposed height of 4'-0".

MSE Wall (Element 8603) - A mechanically stabilized earth (MSE) wall is based on the principle of integrating reinforcing into a granular backfill via means such as metal strips or rods, geosynthetic sheets, or wire grids. The reinforcing is tied to precast concrete facing units, which form the vertical face of the wall. The facing units are relatively small and piece together in a geometric pattern. The reinforcing is attached at regular intervals throughout the width and height of the wall.

MSE Walls can be constructed with different materials including precast concrete panel facings (classic vertical faced MSE walls), Modular Block facings (battered segmental retaining walls), and Wire faced walls. The Segmented Modular Block Retaining Wall is the most common of MSE structure in Wisconsin. Although these walls can act as Gravity walls, they are often constructed as MSE walls.

Post & Panel Wall (Element 8604) - Post and Panel Walls are comprised of vertical elements (usually H piles) and concrete panels which extend between the vertical elements. The panels resist lateral soil pressures by spanning horizontally between the posts. The panels are usually constructed of precast reinforced concrete although precast/prestressed concrete and timber are also possibilities

Sheet Pile Wall (Element 8605) - Sheet pile walls are most often temporary, but may be permanent structures as well. The corrosion potential for these walls is high, and site conditions should be taken into account. A steel sheet pile wall can be a maximum of approximately 15 feet high without tiebacks being required.

Reinforced Soil Slope (Element 8606) - Reinforced soil slopes add tensile inclusions with soil to create a composite material. The tensile inclusions are typically geosynthetic reinforcement. Vegetation can be used as the facing of the composite material for slopes less than 45 degrees but more significant armoring may be needed for steeper slopes such as concrete.

Secant or Tangent Shaft Wall (Element 8607) - Secant and Tangent walls are a series of interlocking concrete shafts. Secant shaft walls have primary shafts that are poured first and then secondary shafts are poured that interlock the primary shafts. The tangent shaft walls are constructed similarly except that the secondary shafts only touch the primary shafts without any of the interlocking properties.

Other Wall and Other Material Wall (Element 8608) - This element is intended to be used for any type of earth retention wall that does not fit into any of the previously mentioned elements.

Noise Barrier Elements

Noise Wall Barrier – Ground Mounted (Element 8609) - A noise barrier mounted to foundations in the ground and is a constructed appurtenance, either alone or integrated with other systems that alter the normal noise travel at a site.

Noise Wall Barrier – Structure Mounted (8610) - A noise barrier mounted to a bridge/wall structure and is a constructed appurtenance, either alone or integrated with other systems that alter the normal noise travel at a site.

Defect Type

Wall Movement (LF) – Defect for wall elements that describe the global movement of the wall.

Material Deterioration (LF) - Defect that describes the material flaws, defects, etc. in the overall wall system.

Masonry or Panel Displacement (LF) - Defect that describes blocks, stones, or panels and their movement in relation to the overall wall.

Chapter 7 – Ancillary Structures – Wall Elements

Element	Defect	Good	Fair	Poor	Severe
Cast-in-Place (CIP) Concrete Wall (8600)	Wall Movement	Wall elements are as constructed, and/or show no signs of settlement, bulging, bending, heaving, or distortion/deflection beyond normal prescribed post-construction limits. Wall elements are fully bearing against retained soil/rock units.	Wall movement has started to occur. Wall shows signs of settlement, bulging, bending, heaving, misalignment, distortion, deflection and/or displacement beyond normal prescribed post construction limits (i.e. wall face rotation, basket budging, anchor head displacement, bin displacement). Wall may be strapped or anchored to prevent further movement, or movement has been arrested through countermeasures. Wall elements are mostly bearing against retained soil/rock units.	Wall rotation/sliding/settlement is active and extensive and well beyond normal post-construction limits; sloughing of retained material behind wall is evident. Wall may have been strapped, anchored or stabilized to prevent further movement, but this device has failed. Many or key wall elements are no longer bearing against retained soil/rock units.	Wall has failed.
Cast-in-Place (CIP) Concrete Wall (8600)	Material Deterioration	No spalls, delaminations, abrasions, or patched areas. Cracks, if they exist, have been sealed or are less than 0.012".	Delaminations may be present. Spalls, if present, are 1" or less in depth or less than 6" in diameter. Patched areas that are sound. If rebar is exposed, there is no section loss. Cracks, if they exist, are between 0.012" - 0.05". Where efflorescence is present, it's minor and no evidence of rust staining. Abrasions, if they exist, have exposed course aggregate but the aggregate remains secure in the concrete.	Spalls greater than 1" deep, or greater than 6" in diameter. Patched areas that are unsound. Exposed rebar, if present, has measurable section loss. Cracks, if present, are greater than 0.05" wide. Where efflorescence is present, there is heavy build-up and/or rust staining. If abrasions are present, the course aggregate is loose or has popped out of the concrete matrix. Conditions are not sufficient to warrant structural review.	The condition warrants a structural review to determine the effect on strength or serviceability of the wall or the wall has failed due to deterioration.

Element	Defect	Good	Fair	Poor	Severe
Gabion Wall (8601)	Wall Movement	Wall elements are as constructed, and/or show no signs of settlement, bulging, bending, heaving, or distortion/deflection beyond normal prescribed post-construction limits. Wall elements are fully bearing against retained soil/rock units.	Wall movement has started to occur. Wall shows signs of settlement, bulging, bending, heaving, misalignment, distortion, deflection and/or displacement beyond normal prescribed post construction limits (i.e. wall face rotation, basket budging, etc.). Wall elements are mostly bearing against retained soil/rock units.	Wall rotation/sliding/settlement is active and extensive and well beyond normal post-construction limits; sloughing of retained material behind wall is evident. Wall may have been stabilized to prevent further movement, but this device has failed. Many or key wall elements are no longer bearing against retained soil/rock units.	Wall has failed.
Gabion Wall (8601)	Material Deterioration	No defects noted.	Freckled rust with corrosion of the steel basket initiating. Loose fasteners without distortion are present but the connection is in place and functioning as intended. Stones are split, but no shifting.	Section loss of the steel basket is evident. Broken or missing fasteners have caused localized distortions. Stones are splitting and spalled with some differential movement but does not warrant a structural review.	The condition warrants a structural review to determine the effect on strength or serviceability of the wall or the wall has failed due to deterioration.

Chapter 7 – Ancillary Structures – Wall Elements

Element	Defect	Good	Fair	Poor	Severe
Gravity (Block & Rubble) Wall (8602)	Wall Movement	Wall elements are as constructed, and/or show no signs of settlement, bulging, bending, heaving, or distortion/deflection beyond normal prescribed post-construction limits. Wall elements are fully bearing against retained soil/rock units.	Wall movement has started to occur. Wall shows signs of settlement, bulging, bending, heaving, misalignment, distortion, deflection and/or displacement beyond normal prescribed post construction limits (i.e. wall face rotation, basket budging, anchor head displacement, bin displacement). Wall may be strapped or anchored to prevent further movement, or movement has been arrested through countermeasures. Wall elements are mostly bearing against retained soil/rock units.	Wall rotation/sliding/settlement is active and extensive and well beyond normal post-construction limits; sloughing of retained material behind wall is evident. Wall may have been strapped, anchored or stabilized to prevent further movement, but this device has failed. Many or key wall elements are no longer bearing against retained soil/rock units.	Wall has failed.
Gravity (Block & Rubble) Wall (8602)	Material Deterioration	No defects noted.	If using mortar, cracking or voids in less than 10% of the joints. Block or stone has split or spalled with no shifting. Patched areas are sound.	If using mortar, cracking or voids in 10% or more of the joints. Block or stone has split or spalled with shifting. Patched areas are not sound. Does not require a structural review.	The condition warrants a structural review to determine the effect on strength or serviceability of the wall or the wall has failed due to deterioration.

Element	Defect	Good	Fair	Poor	Severe
Gravity (Block & Rubble) Wall (8602)	Masonry or Panel Displacement	None	Block, stone, or panel has shifted slightly out of alignment.	Block, stone, or panel has shifted significantly out of alignment or is missing but does not warrant a structural review.	The condition warrants a structural review to determine the effect on strength or serviceability of the element, or a review has been completed and it has been found that the defects impact strength or serviceability.
MSE Wall (8603)	Wall Movement	Wall elements are as constructed, and/or show no signs of settlement, bulging, bending, heaving, or distortion/deflection beyond normal prescribed post-construction limits. Wall elements are fully bearing against retained soil/rock units.	Wall movement has started to occur. Wall shows signs of settlement, bulging, bending, heaving, misalignment, distortion, deflection and/or displacement beyond normal prescribed post construction limits (i.e. wall face rotation, basket budging, anchor head displacement, bin displacement). Wall may be strapped or anchored to prevent further movement, or movement has been arrested through countermeasures. Wall elements are mostly bearing against retained soil/rock units.	Wall rotation/sliding/settlement is active and extensive and well beyond normal post-construction limits; sloughing of retained material behind wall is evident. Wall may have been strapped, anchored or stabilized to prevent further movement, but this device has failed. Many or key wall elements are no longer bearing against retained soil/rock units.	Wall has failed.

Chapter 7 – Ancillary Structures – Wall Elements

Element	Defect	Good	Fair	Poor	Severe
MSE Wall (8603)	Material Deterioration	<p>Segmented Modular Block MSE Walls: No Defects noted.</p> <p>Precast Panel Facing MSE Walls: No spalls, delaminations, abrasions, or patched areas.</p> <p>Cracks, if they exist, have been sealed or are less than 0.012".</p>	<p>Segmented Modular Block MSE Walls: If using mortar, cracking or voids in less than 10% of the joints. Block or stone has split or spalled with no shifting. Patched areas are sound.</p> <p>Precast Panel Facing MSE Walls: Delaminations may be present. Spalls, if present, are 1" or less in depth or less than 6" in diameter. Patched areas that are sound. If rebar is exposed, there is no section loss. Cracks, if they exist, are between 0.012" - 0.05". Where efflorescence is present, it's minor and no evidence of rust staining. Abrasions, if they exist, have exposed coarse aggregate but the aggregate remains secure in the concrete.</p>	<p>Segmented Modular Block MSE Walls: If using mortar, cracking or voids in 10% or more of the joints. Block or stone has split or spalled with shifting. Patched areas are not sound. Does not require a structural review.</p> <p>Precast Panel Facing MSE Walls: Spalls greater than 1" deep, or greater than 6" in diameter. Patched areas that are unsound. Exposed rebar, if present, has measurable section loss. Cracks, if present, are greater than 0.05" wide. Where efflorescence is present, there is heavy build-up and/or rust staining. If abrasions are present, the coarse aggregate is loose or has popped out of the concrete matrix. Conditions are not sufficient to warrant structural review.</p>	<p>The condition warrants a structural review to determine the effect on strength or serviceability of the wall, or the wall has failed due to deterioration.</p>

Element	Defect	Good	Fair	Poor	Severe
MSE Wall (8603)	Masonry or Panel Displacement	None. No movement is observed or measured.	Block, stone, or panel has shifted slightly out of alignment.	Block, stone, or panel has shifted significantly out of alignment or is missing but does not warrant a structural review.	The condition warrants a structural review to determine the effect on strength or serviceability of the element, or a review has been completed and it has been found that the defects impact strength or serviceability.
Post & Panel Wall (8604)	Wall Movement	Wall elements are as constructed, and/or show no signs of settlement, bulging, bending, heaving, or distortion/deflection beyond normal prescribed post-construction limits. Wall elements are fully bearing against retained soil/rock units.	Wall movement has started to occur. Wall shows signs of settlement, bulging, bending, heaving, misalignment, distortion, deflection and/or displacement beyond normal prescribed post construction limits (i.e. wall face rotation, basket budging, anchor head displacement, bin displacement). Wall may be strapped or anchored to prevent further movement, or movement has been arrested through countermeasures. Wall elements are mostly bearing against retained soil/rock units.	Wall rotation/sliding/settlement is active and extensive and well beyond normal post-construction limits; sloughing of retained material behind wall is evident. Wall may have been strapped, anchored or stabilized to prevent further movement, but this device has failed. Many or key wall elements are no longer bearing against retained soil/rock units.	Wall has failed.

Chapter 7 – Ancillary Structures – Wall Elements

Element	Defect	Good	Fair	Poor	Severe
<p>Post & Panel Wall (8604)</p>	<p>Material Deterioration</p>	<p>No defects noted.</p>	<p>Steel Posts with Concrete Panels: Delaminations may be present. Spalls, if present, are 1" or less in depth or less than 6" in diameter. Patched areas that are sound. If rebar is exposed, there is no section loss. Cracks, if they exist, are between 0.012" - 0.05". Where efflorescence is present, it's minor and no evidence of rust staining. Abrasions, if they exist, have exposed course aggregate but the aggregate remains secure in the concrete. Freckle rust on the posts. Corrosion of the steel has initiated. Cracking of the steel has self-arrested, or has been arrested with effective holes, doubling plates, or similar. Fasteners may be loose, but are performing the intended function.</p> <p>Steel Posts with Timber Panels: Decay or section loss of the timber affects <10% of the member section. Checks/Cracks penetrate <5% of the timber member thickness. Timber members do not have splits/shakes/delaminations. Section loss of the timber due to abrasion is < 10% of the member thickness. Freckle rust on the steel posts. Corrosion of the steel has initiated. Cracking of the steel has self-arrested, or has been arrested with effective holes, doubling plates, or similar. Fasteners may be loose, but are performing the intended function.</p>	<p>Steel Posts with Concrete Panels: Spalls greater than 1" deep, or greater than 6" in diameter. Patched areas that are unsound. Exposed rebar, if present, has measurable section loss. Cracks, if present, are greater than 0.05" wide. Where efflorescence is present, there is heavy build-up and/or rust staining. If abrasions are present, the course aggregate is loose or has popped out of the concrete matrix. Section loss of the posts is evident. Cracks exist in the steel that have not been arrested. Missing bolts, broken welds, or other fastener damage with some distortion. Conditions are not sufficient to warrant structural review.</p> <p>Steel Posts with Timber Panels: Decay or section loss of the timber affects 10% or more of the member. Checks/cracks penetrate 5%~50% of the member thickness. Timber member has splits/shakes with length less than member depth. Larger cracks/splits/shakes have been arrested with effective repairs. Section loss of the timber member due to abrasion is 10% or more of the member thickness. Section loss of the steel posts is evident. Cracks exist in the steel that have not been arrested. Missing bolts, broken welds, or other fastener damage with some distortion. Conditions are not sufficient to warrant structural review.</p>	<p>The condition warrants a structural review to determine the effect on strength or serviceability of the wall, or the wall has failed due to deterioration.</p>

Element	Defect	Good	Fair	Poor	Severe
Post & Panel Wall (8604)	Masonry or Panel Displacement	None	Block, stone, or panel has shifted slightly out of alignment.	Block, stone, or panel has shifted significantly out of alignment or is missing but does not warrant a structural review.	The condition warrants a structural review to determine the effect on strength or serviceability of the element, or a review has been completed and it has been found that the defects impact strength or serviceability.
Sheet Pile Wall (8605)	Wall Movement	Wall elements are as constructed, and/or show no signs of settlement, bulging, bending, heaving, or distortion/deflection beyond normal prescribed post-construction limits. Wall elements are fully bearing against retained soil/rock units.	Wall movement has started to occur. Wall shows signs of settlement, bulging, bending, heaving, misalignment, distortion, deflection and/or displacement beyond normal prescribed post construction limits (i.e. wall face rotation, basket budging, anchor head displacement, bin displacement). Wall may be strapped or anchored to prevent further movement, or movement has been arrested through countermeasures. Wall elements are mostly bearing against retained soil/rock units.	Wall rotation/sliding/settlement is active and extensive and well beyond normal post-construction limits; sloughing of retained material behind wall is evident. Wall may have been strapped, anchored or stabilized to prevent further movement, but this device has failed. Many or key wall elements are no longer bearing against retained soil/rock units.	Wall has failed.

Chapter 7 – Ancillary Structures – Wall Elements

Element	Defect	Good	Fair	Poor	Severe
Sheet Pile Wall (8605)	Material Deterioration	No defects noted.	Freckle rust on the steel. Corrosion of the steel has initiated. Cracking of the steel has self-arrested, or has been arrested with effective holes, doubling plates, or similar. Fasteners may be loose, but are performing the intended function.	Section loss of the steel posts is evident. Cracks exist in the steel that have not been arrested. Missing bolts, broken welds, or other fastener damage with some distortion. Conditions are not sufficient to warrant structural review.	The condition warrants a structural review to determine the effect on strength or serviceability of the wall, or the wall has failed due to deterioration.
Reinforced Soil Slope (8606)	Wall Movement	Wall elements are as constructed, and/or show no signs of settlement, bulging, bending, heaving, or distortion/deflection beyond normal prescribed post-construction limits. Wall elements are fully bearing against retained soil/rock units.	Wall movement has started to occur. Wall shows signs of settlement, bulging, bending, heaving, misalignment, distortion, deflection and/or displacement beyond normal prescribed post construction limits (i.e. wall face rotation, basket budging, anchor head displacement, bin displacement). Wall may be strapped or anchored to prevent further movement, or movement has been arrested through countermeasures. Wall elements are mostly bearing against retained soil/rock units.	Wall rotation/sliding/settlement is active and extensive and well beyond normal post-construction limits; sloughing of retained material behind wall is evident. Wall may have been strapped, anchored or stabilized to prevent further movement, but this device has failed. Many or key wall elements are no longer bearing against retained soil/rock units.	Wall has failed.

Element	Defect	Good	Fair	Poor	Severe
Reinforced Soil Slope (8606)	Material Deterioration	No defects noted.	The material has deterioration described in the applicable CS2 material defects for section loss and wall integrity.	The material has deterioration described in the applicable CS3 material defects for section loss and wall integrity.	The condition warrants a structural review to determine the effect on strength or serviceability of the wall, or the wall has failed due to deterioration.
Secant or Tangent Shaft Wall (8607)	Wall Movement	Wall elements are as constructed, and/or show no signs of settlement, bulging, bending, heaving, or distortion/deflection beyond normal prescribed post-construction limits. Wall elements are fully bearing against retained soil/rock units.	Wall movement has started to occur. Wall shows signs of settlement, bulging, bending, heaving, misalignment, distortion, deflection and/or displacement beyond normal prescribed post construction limits (i.e. wall face rotation, basket budging, anchor head displacement, bin displacement). Wall may be strapped or anchored to prevent further movement, or movement has been arrested through countermeasures. Wall elements are mostly bearing against retained soil/rock units.	Wall rotation/sliding/settlement is active and extensive and well beyond normal post-construction limits; sloughing of retained material behind wall is evident. Wall may have been strapped, anchored or stabilized to prevent further movement, but this device has failed. Many or key wall elements are no longer bearing against retained soil/rock units.	Wall has failed.

Chapter 7 – Ancillary Structures – Wall Elements

Element	Defect	Good	Fair	Poor	Severe
Secant or Tangent Shaft Wall (8607)	Material Deterioration	<p>No spalls, delaminations, abrasions, or patched areas. Cracks, if they exist, have been sealed or are less than 0.012".</p>	<p>Delaminations may be present. Spalls, if present, are 1" or less in depth or less than 6" in diameter. Patched areas that are sound. If rebar is exposed, there is no section loss. Cracks, if they exist, are between 0.012" - 0.05". Where efflorescence is present, it's minor and no evidence of rust staining. Abrasions, if they exist, have exposed course aggregate but the aggregate remains secure in the concrete.</p>	<p>Spalls greater than 1" deep, or greater than 6" in diameter. Patched areas that are unsound. Exposed rebar, if present, has measurable section loss. Cracks, if present, are greater than 0.05" wide. Where efflorescence is present, there is heavy build-up and/or rust staining. If abrasions are present, the course aggregate is loose or has popped out of the concrete matrix. Conditions are not sufficient to warrant structural review.</p>	<p>The condition warrants a structural review to determine the effect on strength or serviceability of the wall, or the wall has failed due to deterioration.</p>
Other Wall (8608)	Wall Movement	<p>Wall elements are as constructed, and/or show no signs of settlement, bulging, bending, heaving, or distortion/deflection beyond normal prescribed post-construction limits. Wall elements are fully bearing against retained soil/rock units.</p>	<p>Wall movement has started to occur. Wall shows signs of settlement, bulging, bending, heaving, misalignment, distortion, deflection and/or displacement beyond normal prescribed post construction limits (i.e. wall face rotation, basket budging, anchor head displacement, bin displacement). Wall may be strapped or anchored to prevent further movement, or movement has been arrested through countermeasures. Wall elements are mostly bearing against retained soil/rock units.</p>	<p>Wall rotation/sliding/settlement is active and extensive and well beyond normal post-construction limits; sloughing of retained material behind wall is evident. Wall may have been strapped, anchored or stabilized to prevent further movement, but this device has failed. Many or key wall elements are no longer bearing against retained soil/rock units.</p>	<p>Wall has failed.</p>

Element	Defect	Good	Fair	Poor	Severe
Other Wall (8608)	Material Deterioration	No defects noted.	The material has deterioration described in the applicable CS2 material defects for section loss and wall integrity.	The material has deterioration described in the applicable CS3 material defects for section loss and wall integrity.	The condition warrants a structural review to determine the effect on strength or serviceability of the wall, or the wall has failed due to deterioration.
Noise Wall Barrier – Ground Mounted (8609)	Wall Movement	Wall elements are as constructed, and/or show no signs of settlement, bulging, bending, heaving, or distortion/ deflection beyond normal prescribed post-construction limits.	Wall movement has started to occur. Wall shows signs of settlement, bulging, bending, heaving, misalignment, distortion, deflection and/or displacement beyond normal prescribed post construction limits (i.e. wall face rotation, basket budging, anchor head displacement, bin displacement). Wall may be strapped or anchored to prevent further movement, or movement has been arrested through countermeasures.	Wall rotation/sliding/settlement is active and extensive and well beyond normal post-construction limits; sloughing of retained material behind wall is evident. Wall may have been strapped, anchored or stabilized to prevent further movement, but this device has failed.	Wall has failed.

Chapter 7 – Ancillary Structures – Wall Elements

Element	Defect	Good	Fair	Poor	Severe
Noise Wall Barrier – Ground Mounted (8609)	Material Deterioration	No defects noted.	<p>Steel Posts with Concrete Panels: Delaminations may be present. Spalls, if present, are 1" or less in depth or less than 6" in diameter. Patched areas that are sound. If rebar is exposed, there is no section loss. Cracks, if they exist, are between 0.012" - 0.05". Where efflorescence is present, it's minor and no evidence of rust staining. Abrasions, if they exist, have exposed course aggregate but the aggregate remains secure in the concrete. Freckle rust on the posts. Corrosion of the steel has initiated. Cracking of the steel has self-arrested, or has been arrested with effective holes, doubling plates, or similar. Fasteners may be loose, but are performing the intended function.</p> <p>Steel Posts with Timber Panels: Decay or section loss of the timber affects <10% of the member section. Checks/Cracks penetrate <5% of the timber member thickness. Timber members do not have splits/shakes/delaminations. Section loss of the timber due to abrasion is < 10% of the member thickness. Freckle rust on the steel posts. Corrosion of the steel has initiated. Cracking of the steel has self-arrested, or has been arrested with effective holes, doubling plates, or similar. Fasteners may be loose, but are performing the intended function.</p>	<p>Steel Posts with Concrete Panels: Spalls greater than 1" deep, or greater than 6" in diameter. Patched areas that are unsound. Exposed rebar, if present, has measurable section loss. Cracks, if present, are greater than 0.05" wide. Where efflorescence is present, there is heavy build-up and/or rust staining. If abrasions are present, the course aggregate is loose or has popped out of the concrete matrix. Section loss of the posts is evident. Cracks exist in the steel that have not been arrested. Missing bolts, broken welds, or other fastener damage with some distortion. Conditions are not sufficient to warrant structural review.</p> <p>Steel Posts with Timber Panels: Decay or section loss of the timber affects 10% or more of the member. Checks/cracks penetrate 5%~50% of the member thickness. Timber member has splits/shakes with length less than member depth. Larger cracks/splits/shakes have been arrested with effective repairs. Section loss of the timber member due to abrasion is 10% or more of the member thickness. Section loss of the steel posts is evident. Cracks exist in the steel that have not been arrested. Missing bolts, broken welds, or other fastener damage with some distortion. Conditions are not sufficient to warrant structural review.</p>	The condition warrants a structural review to determine the effect on strength or serviceability of the wall or the wall has failed due to deterioration.

Element	Defect	Good	Fair	Poor	Severe
Noise Wall Barrier – Ground Mounted (8609)	Masonry or Panel Displacement	None	Block, stone, or panel has shifted slightly out of alignment.	Block, stone, or panel has shifted significantly out of alignment or is missing but does not warrant a structural review.	The condition warrants a structural review to determine the effect on strength or serviceability of the element, or a review has been completed and it has been found that the defects impact strength or serviceability.
Noise Wall Barrier – Structure Mounted (8610)	Wall Movement	Wall elements are as constructed, and/or show no signs of settlement, bulging, bending, heaving, or distortion/deflection beyond normal prescribed post-construction limits.	Wall movement has started to occur. Wall shows signs of settlement, bulging, bending, heaving, misalignment, distortion, deflection and/or displacement beyond normal prescribed post construction limits (i.e. wall face rotation, basket budging, anchor head displacement, bin displacement). Wall may be strapped or anchored to prevent further movement, or movement has been arrested through countermeasures.	Wall rotation/sliding/settlement is active and extensive and well beyond normal post-construction limits; sloughing of retained material behind wall is evident. Wall may have been strapped, anchored or stabilized to prevent further movement, but this device has failed.	Wall has failed.

Chapter 7 – Ancillary Structures – Wall Elements

Element	Defect	Good	Fair	Poor	Severe
Noise Wall Barrier – Structure Mounted (8610)	Material Deterioration	No defects noted.	<p>Steel Posts with Concrete Panels: Delaminations may be present. Spalls, if present, are 1" or less in depth or less than 6" in diameter. Patched areas that are sound. If rebar is exposed, there is no section loss. Cracks, if they exist, are between 0.012" - 0.05". Where efflorescence is present, it's minor and no evidence of rust staining. Abrasions, if they exist, have exposed course aggregate but the aggregate remains secure in the concrete. Freckle rust on the posts. Corrosion of the steel has initiated. Cracking of the steel has self-arrested, or has been arrested with effective holes, doubling plates, or similar. Fasteners may be loose, but are performing the intended function.</p> <p>Steel Posts with Timber Panels: Decay or section loss of the timber affects <10% of the member section. Checks/Cracks penetrate <5% of the timber member thickness. Timber members do not have splits/shakes/delaminations. Section loss of the timber due to abrasion is < 10% of the member thickness. Freckle rust on the steel posts. Corrosion of the steel has initiated. Cracking of the steel has self-arrested, or has been arrested with effective holes, doubling plates, or similar. Fasteners may be loose, but are performing the intended function.</p>	<p>Steel Posts with Concrete Panels: Spalls greater than 1" deep, or greater than 6" in diameter. Patched areas that are unsound. Exposed rebar, if present, has measurable section loss. Cracks, if present, are greater than 0.05" wide. Where efflorescence is present, there is heavy build-up and/or rust staining. If abrasions are present, the course aggregate is loose or has popped out of the concrete matrix. Section loss of the posts is evident. Cracks exist in the steel that have not been arrested. Missing bolts, broken welds, or other fastener damage with some distortion. Conditions are not sufficient to warrant structural review.</p> <p>Steel Posts with Timber Panels: Decay or section loss of the timber affects 10% or more of the member. Checks/cracks penetrate 5%~50% of the member thickness. Timber member has splits/shakes with length less than member depth. Larger cracks/splits/shakes have been arrested with effective repairs. Section loss of the timber member due to abrasion is 10% or more of the member thickness. Section loss of the steel posts is evident. Cracks exist in the steel that have not been arrested. Missing bolts, broken welds, or other fastener damage with some distortion. Conditions are not sufficient to warrant structural review.</p>	The condition warrants a structural review to determine the effect on strength or serviceability of the wall, or the wall has failed due to deterioration.

Ancillary Assessments

Ancillary Assessments

9200 – Rodent Screen	Signs, Signals, HML	EA
9201 – Electrical, Luminaire Device, and/or Camera	HML	EA
9202 – Miscellaneous Mounted Attachments	Signs, Signals, HML	EA
9204 – Winch and Cables	HML	EA
9205 – Handhole Covers and Caps	Signs, Signals, HML	EA
9206 – Catwalk	Signs	EA
9207 – Crash Protection (Guardrail, Barrier, etc.)	Signs, Signals, HML	EA
9208 – Structure ID Plaque	All	EA
9209 – Protective Coating(s) (Galvanization, Paint, etc.)	Signs, Signals, HML	EA
9338 – Horizontal Copings	Walls	LF
9339 – Features Adjacent to Wall (Roadways, Sidewalks, Retained Material, Slopes, Etc.)	Walls	EA
9340 – Drainage Systems Along Wall	Walls	EA
9341 – Stairwell	Walls	EA

Ancillary Assessments

Rodent Screen (Signs/Signals/HML) (Element 9200) - This assessment defines the presence and condition of the screen used to keep rodents from accessing the underside of the baseplate area.

Electrical, Luminaire Device, and/or Camera (HML Only) (Element 9201) - This assessment defines the visual condition of luminaires and/or cameras in the system on the structure, as well as the visual condition of the electrical boxes. A separate electrical inspection covers the electrical systems in detail.

Miscellaneous Mounted Attachments (Signs/Signal/HML) (Element 9202) - This assessment defines the presence and condition of cameras, walk signals, miscellaneous signs, electrical boxes, traffic control counters, dampeners, etc. mounted to the structure, as well as connections for these items.

Winch and Cables (HML Only) (Element 9204) - This assessment defines the visual condition of the winch and cable system used to hoist and suspend the luminaire in HML structures. This includes the support brackets, housing anchorage, and cable attachments. A separate electrical inspection covers the motor and mechanical system used to raise and lower the luminaire.

Handhole Covers and Caps (Signs/Signals/HML) (Element 9205) - This assessment defines handhole covers and caps for columns, chords, and mast-arms.

Catwalk (Signs Only) (Element 9206) - This assessment defines the walkway gratings, handrails, safety chains, and connections on the structure.

Crash Protection (Guardrail, Barrier, etc.) (Signs/Signals/HML) (Element 9207) - This assessment defines the state of devices used to protect the structure. Evaluate for a distance of no more than 50FT from the structure, or as deemed appropriate by the engineer.

Structure ID Plaque (All types) (Element 9208) - This assessment defines the plaque used to identify the structure.

Protective Coating(s) (Galvanization, Paint, etc.) (Signs/Signals/HML) (Element 9209) - This assessment defines the overall condition of the protective system(s) of the metal component of the structure.

Horizontal Copings (Walls Only) (Element 9338) - The horizontal coping is attached to the top of the wall and provides protection from deterioration caused by water runoff, snow, freeze/thaw, and ice by diverting water away from vertical seams, the top of the wall, and the wall facing.

Features Adjacent to Wall (Roadways, Sidewalks, Retained Material, Slopes, etc.) (Walls Only) (Element 9339) - For retaining walls, the slope behind the wall should be stable and adequately supported by the wall. Any backfill losses, indication of water retention, or other defects may indicate performance issues with the wall and should be noted. Also use for sidewalks, trails, roadways, driveways, or other facilities that are carried by the wall. Only assess if facility has a direct impact on the wall. Assess as an EACH quantity, with one for features above retaining walls, and one for features in front of both retaining walls and noise walls.

Drainage Systems Along Walls (Walls Only) (Element 9340) - This defines the drainage system(s) related to the wall. There will be one EACH for both drainage systems above walls, and one EACH for drainage systems in front of walls.

Stairwell (Walls Only) (Element 9341) - This defines the treads, risers, nosing, and hand rails that make up the stairway within a retaining wall structure. The sides of the stairwell will be evaluated as part of the retaining wall structure.

Name	Good	Fair	Poor	Severe
Rodent Screen (9200)	Rodent screen is present and is in good condition.	Rodent screen is present - it may have some damage or deterioration but it is performing the intended function.	Rodent screen is present - it may have some damage or deterioration and is not performing the intended function.	Rodent screen is absent on structures where it is required, or incorrectly installed where it does not function properly.
Electrical, Luminaire Device, and/or Camera (HML ONLY) (9201)	Components appear to be fully functioning.	Minor damage or misalignment is noted. Light cover latches are broken.	Broken or missing lenses. Bulbs are burnt out or missing. Camera (if present) does not appear to be functioning.	Significant damage or deterioration is visible that threatens separation of component from the pole structure.
Miscellaneous Mounted Attachments (9202)	Components appear to be fully functioning.	The element(s) exist and are performing the intended function. Minor corrosion or damage exists.	Moderate damage or misalignment exists. The elements may be loose and need tightening.	Element is missing, or is significantly damaged and not performing the intended function.
Winch and Cables (9204)	Elements appear to be fully functioning.	Bolts may be loose or missing. Elements may be out of alignment.	Housing may be bent or cracked. Cable anchorages may be loose, damaged or missing. Cables may be kinked, tangled, fraying, or damaged.	The element is damaged or deteriorated to the point that failure is eminent.
Handhole Covers and Caps (9205)	The element(s) are present and show no deterioration.	The element(s) exist and are performing the intended function. Minor corrosion or damage exists.	Moderate corrosion or damage exists. The element may be loose and need tightening.	Element is missing, or is significantly damaged and not performing the intended function.

Chapter 7 – Ancillary Assessments

Name	Good	Fair	Poor	Severe
Catwalk (9206)	The element shows no deterioration.	Minor damage and/or deterioration may be observed. Handrails and locking pins may be misaligned. Safety chains may be deteriorated.	Moderate deterioration and/or damage. Sections of gratings or handrails may be unstable, damaged or missing. Safety chains are missing, or inoperable. Handrails and locking pins may be inoperable.	Significant damage or deterioration is visible that threatens separation of component from the structure. There is sufficient concern to warrant structural analysis to ascertain the impact on strength or serviceability, or a review has been completed and it has been found that the defects impact strength or serviceability.
Crash Protection (Guardrail, Barrier, etc.) (9207)	The element shows no deterioration.	Minor damage or deterioration is noted. Element is still performing its intended function.	Minor damage or deterioration is noted. Element is still performing its intended function.	Significant damage or deterioration is visible. There is sufficient concern to warrant structural analysis to ascertain the impact on strength or serviceability, or a review has been completed and it has been found that the defects impact strength or serviceability.
Structure ID Plaque (9208)	The element is present and shows no deterioration.	The element is present, but has minor deterioration.	The element is present, though may not be installed in the correct location. The element may have moderate deterioration.	The element is missing, illegible, or incorrect.
Protective Coating(s) (Galvanization, Paint, etc.) (9209)	The coating(s) are fully effective.	The coating(s) are substantially effective, though small areas of peeling, dulling, bubbling or cracking of the coating may be present.	The coating(s) have limited effectiveness and need touch-up work.	The coating system has failed, and provides no protection to the underlying metal for a majority of the structure.

Name	Good	Fair	Poor	Severe
Horizontal Copings (9338)	No issues. If cracks exist, they are <1/16" in width or sealed.	Delaminations or spalls 1" or less, or less than 6" diameter. Patches, if they exist, are sound. HL or narrow cracking may be present. Minor efflorescence may exist, but no rust staining. Abrasion, if present, is minor.	Spall greater than 1" deep, or 6" diameter. Patched areas are unsound or showing distress. Medium width cracks. When efflorescence is present, there is heavy build-up and/or rust staining. Abrasion, if it exists, is moderate.	The condition warrants a structural review to determine the effect on strength or serviceability of the wall; or a structural review has been completed and the defects impact the strength and/or serviceability of the wall.
Features Adjacent to Wall (Roadways, Sidewalks, Retained Material, Slopes, Etc.) (9339)	No issues with retained material. The facilities, if they exist, are generally smooth and show no signs of settlement. No slope erosion is evident, nor are any signs of settlement of the slope.	Settlement exists but within tolerable limits with no structural distress observed. The facilities, if they exist, may have minor settlement and/or may be cracked and deteriorated.	Settlement exists that exceeds tolerable limits with no structural distress observed, nor structural review required. The facilities, if they exist, may have moderate deterioration and/or may be cracked and deteriorated.	The condition warrants a structural review to determine the effect on strength or serviceability of the wall; or a structural review has been completed and the defects impact the strength and/or serviceability of the wall.
Drainage Systems Along Wall (9340)	Drainage systems are functioning properly.	Minor erosion of slope. Drainage system is plugged or has minor deterioration.	Moderate erosion of the slope. Drainage system are plugged or have moderate deterioration. Minor slope failures have occurred either removing or adding material from the wall area.	Major erosion of slopes. Drainage system are plugged and have major deterioration. Substantial slope failures have occurred either removing or adding materials to the wall area.
Stairwell (9341)	Good condition without defects and functioning as intended. Stairwell may have superficial or cosmetic cracks, spalls, or stains.	Fair condition with superficial or cosmetic cracks, spalls, stains, or light corrosion; defects are present, but are not a structural concern.	Poor condition with moderate deterioration or defects that may be a structural issue such as settlement, heaving, tipping, misalignment, scaling, heavy corrosion, etc. Early signs of structural defects.	Stairwell has major deterioration or defects that are a structural concern. Evaluate and close stairwell to restrict access, if necessary.

THIS PAGE IS INTENTIONALLY LEFT BLANK

Chapter 8: Critical Findings Procedure

Chapter 8. Critical Findings Procedure

A Critical Findings Policy Memo exists on the WisDOT Inspection website at <http://www1.wisconsin.gov/Pages/doing-bus/eng-consultants/cnslt-rsrcs/strct/maintenance-policy-memos.aspx>. The following information is a summary of that document. For full details consult the Policy Memo. This policy memo on the website may go away in the future once incorporated in the next release of the Structures Inspection Manual.

A Critical Finding is defined as “a bridge or portion thereof, discovered either by bridge inspection or notification by the public, which critically threatens the structural stability of the bridge and/or the public safety, and is of such severity that immediate partial or full closure of the structure is warranted”.

Events/Incidents are classified based on varying levels of severity, as follows:

- 1 – Unsafe – Bridge is closed ASAP; may require bridge replacement or major rehabilitation
- 2 – Severe – Bridge is restricted ASAP; may include partial closures and/or load restrictions

Only classifications of Urgent or Severe are considered Critical Findings. These cases will invoke the following notification process and require the submission of DT 2026 (“Critical Findings Report”) through the HSIS inspection database.

Involved Party	Contacted By
Program Manager	Inspector
Bridge Owner	Program Manager
Regional Program Manager	Program Manager
Statewide Program Manager [Lead]	Program Manager
Regional Operations Manager	Regional Program Manager
State Bridge Rating Engineer	Statewide Program Manager
FHWA Division Bridge Engineer	Statewide Program Manager

- Onset Inspection (inspection in which Critical Finding was discovered) shall be entered with the Critical Finding Activity checked and shall be accompanied by a DT 2026 Form with the “Initial Assessment” section filled out.
- Close-out Inspection (inspection after short-term follow-up actions are completed) shall be entered with the Critical Finding Activity checked and shall be accompanied by a completed DT 2026 Form.
- Critical Findings on Movable Span Structures will require the Inspection TL to also notify to the U.S. Coast Guard at (414) 741-7100 (Coast Guard Sector Lake Michigan) or (314) 269-2500 (Coast Guard Sector Upper Mississippi River) for the East and West sides of the State, respectively.

Chapter 9. NBI Rating System

NBI Deck, Superstructure, Substructure Rating System

The following criteria should be used to rate items 58 (Deck), 59 (Superstructure), and 60 (Substructure).

NBI		Description
N	NA	Not Applicable
9	Good	Excellent condition
8		Very good condition – no problems noted
7		Good condition – some minor problems
6	Fair	Satisfactory condition – structural elements show some minor deterioration
5		Fair condition – all primary structural elements are sound, but may have minor section loss, cracking, spalling, or scour
4	Poor	Poor condition – advanced section loss, deterioration, spalling, or scour
3		Serious condition – loss of section, deterioration, spalling, or scour have seriously affected primary structural components. Local failures are possible. Fatigue cracks in steel or shear cracks in concrete may be present.
2	Severe	Critical condition – advanced deterioration of primary structural elements. Fatigue cracks in steel or shear cracks in concrete may be present or scour may have removed substructure support. Unless closely monitored it may be necessary to close the bridge until corrective action is taken.
1		“Imminent” failure condition – major deterioration or section loss in critical structural components or obvious vertical or horizontal movement affecting structure ability. Bridge is closed to traffic but with corrective action may put back in light service.
0		Failed condition – out of service – beyond corrective action

NBI Commentary

- When a deck has a wearing surface and the bottom side of the deck/flange is not accessible for inspection (e.g. adjacent box beams, decks with stay-in-place forms, etc.), then the deck should be rated on based on the condition of the wearing surface. Non-destructive or partially destructive testing methods can be used to further assess the condition.

Chapter 9 – NBI Rating System

Quick Assessment Chart for NBI Deck Rating vs. Defect Comparison

DECK RATING	CRACKING	SCALING	SPALLING	DELAM.	ELECTRICAL POTENTIAL	CHLORIDE CONTENT (LB/CY)
9	None	None	None	None	0	0
8	Minor Transverse	None	None	None	None > 0.35	None > 2.0
7	Sealable	Light	None but Visible Tire Wear	None	10% > 0.35	10% > 2.0
6	Excessive (open cracks @ 5 foot Max. Spa.)	Medium	< 2%	< 5%	10% -20% > 0.35	10%-20% > 2.0
5	Excessive	Heavy	2% - 5%	5% - 20%	20%-40% > 0.35	20%-40% > 2.0
4	Many Full Depth Failures Present or imminent; leaching			> 20%	Over 60% > 0.35	Over 60% > 2.0
3	Many Full Depth Failures Present or imminent; leaching					
2	Full Depth Failures over Much of Deck					
1	Bridge Closed. Corrective Action May Put Back in Service					
0	Bridge Closed. Replacement necessary					

Note: Values are guidelines only

ELEMENTS NBI

SLAB

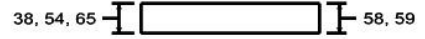

VOIDED SLAB



INVERTED TEE

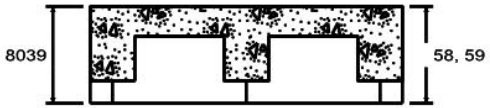

ELEMENTS NBI

REINFORCED CONCRETE TEE-BEAM

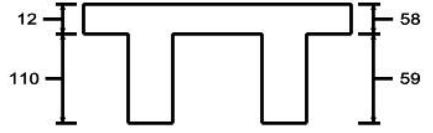

GIRDER

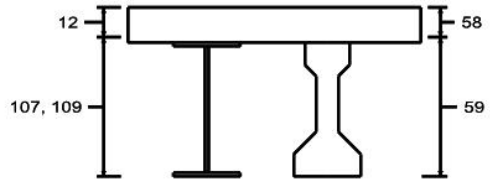

Chapter 9 – NBI Rating System

ELEMENTS

NBI

ADJACENT PRESTRESSED OR REINFORCED CONCRETE UNITS

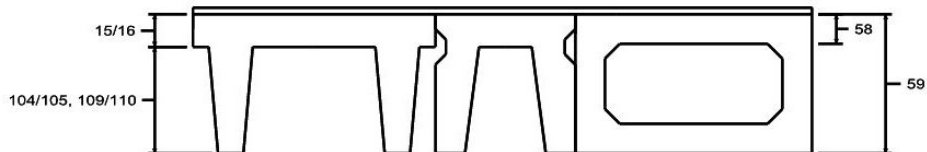

SPREAD BOX GIRDERS

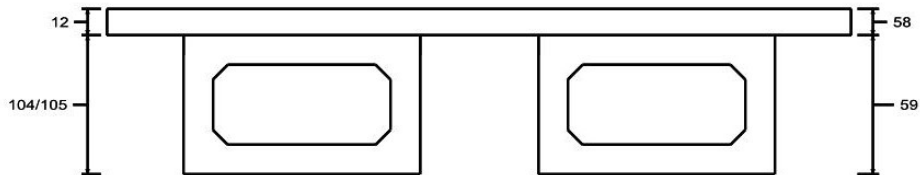

REINFORCED CONCRETE THROUGH GIRDER



CONCRETE BOX GIRDER

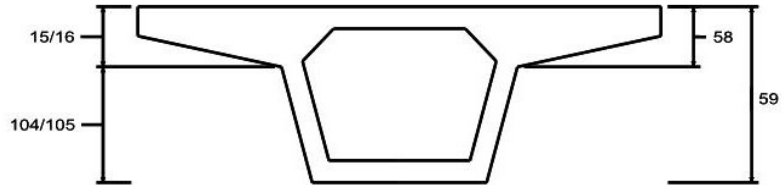

STEEL BOX GIRDER

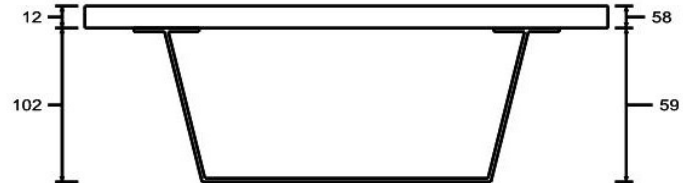

Chapter 9 – NBI Rating System

NBI Culvert Ratings

These criteria should be used to rate item 62 (Culvert). Further detail on culvert rating can be found in the Wisconsin Inspection Structure Manual.

NBI		Description
N	NA	Not Applicable
9	Good	No deficiencies
8		No noticeable or noteworthy deficiencies which affect the condition of the culvert. Insignificant scrape marks caused by drift.
7		Shrinkage cracks, light scaling, and insignificant spalling which does not expose reinforcing steel. Insignificant damage caused by drift with no misalignment and not requiring corrective action. Some minor scouring has occurred near curtain walls, wingwalls, or pipes. Metal culverts have smooth symmetrical curvature with superficial corrosion and not pitting.
6	Fair	Deterioration or initial disintegration, minor chloride contamination, cracking with some leaching, or spalls on concrete or masonry walls and slabs. Local minor scouring at curtain walls, wingwalls, or pipes. Metal culverts have smooth curvature, non-symmetrical shape, significant corrosion and moderate pitting.
5		Moderate to major deterioration or disintegration, extensive cracking and leaching, or spalls on concrete or masonry walls and slabs. Minor settlement or misalignment. Noticeable scouring or erosion at curtain walls, wingwalls or pipes. Metal culverts have significant corrosion or deep pitting.
4	Poor	Large spalls, heavy scaling, wide cracks, considerable efflorescence, or opened construction joint permitting loss of backfill. Considerable settlement or misalignment. Considerable scouring or erosion at curtain walls, wingwalls, or pipes. Metal culverts have significant distortion and deflection throughout, extensive corrosion or deep pitting.
3		Any condition which is described in Code 4 but which is excessive in scope. Severe movement or differential settlement of the segments, or loss of fill. Holes may exist in walls or slabs. Integral wingwalls nearly severed from culvert. Severe scour or erosion at curtain walls, wingwalls, or pipes. Metal culverts have extreme distortion and deflection in one section, extensive corrosion, or deep pitting with scattered perforations.
2	Severe	Integral wingwalls collapsed, severe settlement of roadway due to loss of fill. Section of Culvert may have failed and can no longer support embankment. Complete undermining at curtain walls and pipes. Corrective action required to maintain traffic. Metal culverts have extreme distortion and deflection throughout with extensive perforations due to corrosion.
1		Bridge closed. Corrective action may put back in light service.
0		Bridge closed. Replacement necessary

NBI Channel and Channel Protection

This item describes the physical conditions associated with the flow of water through the bridge such as stream stability and condition of the channel, riprap, slope protection, or stream control devices including spur dikes. The following codes should be used as a guide in evaluating the condition of the channel and channel protection. Further detail on channel condition rating can be found in the WisDOT Structure Inspection Manual.

NBI		Description
N	NA	Not applicable. Use when bridge is not over waterway.
9	Good	There are no noticeable or noteworthy deficiencies which affect the condition of the channel.
8		Banks protected or well vegetated. River control devices (spur dikes, embankment protection are not required or in stable condition).
7		Bank protection is in need of minor repairs. River control devices such as spur dikes and embankment protection have a little minor damage. Banks and/or channel have minor amounts of drift.
6	Fair	Bank is beginning to slump. River control devices and embankment protection have widespread minor damage. There is minor streambed movement evident. Debris is restricting the waterway slightly.
5		Bank protection is being eroded. River control devices and/or embankment have major damage. Trees and brush restrict the channel.
4	Poor	Bank and embankment protection is severely undermined. River control devices have severe damage. Large deposits of debris are in the waterway.
3		Bank protection has failed. River control devices have been destroyed. Streambed aggregation, degradation or lateral movement has changed the waterway to now threaten the bridge and/or approach roadway.
2	Severe	The waterway has changed to the extent the bridge is near a state of collapse.
1		Bridge is closed because of channel failure. Corrective may put back in light service.
0		Bridge is closed because of channel failure. Replacement necessary.

NBI Waterway Adequacy

Waterway adequacy is an appraisal of the existing bridge opening to handle the water flowing through the given opening. Rate the frequency of overtopping the bridge and/or the approach roadway. The following coding should be used as a guide in appraising this item.

Functional Classifications

Principal Arterials, Interstates, Freeways, or Expressways			
Other Principal and Minor Arterials and Major Collectors			
Minor Collectors, Locals			
Code			Description
N	N	N	Bridge is not over waterway.
9	9	9	Bridge deck and roadway approaches above floodwater elevations (high water). Chance of overtopping is remote.
8	8	8	Bridge deck above roadway approaches. Slight chance of overtopping bridge deck.
6	6	7	Slight chance of overtopping bridge deck and roadway approaches.
4	5	6	Bridge deck above roadway approaches. Occasional overtopping of roadway approaches with insignificant traffic delays.
3	4	5	Bridge deck above roadway approaches. Occasional overtopping of roadway approaches with significant traffic delays.
2	3	4	Occasional overtopping of bridge deck and roadway approaches with significant traffic delays.
2	2	3	Frequent overtopping of bridge deck and roadway approaches with significant traffic delays.
2	2	2	Occasional or frequent overtopping of bridge deck and roadway approaches with severe traffic delays.
0	0	0	Bridge Closed.

NBI Approach Roadway Alignment

Code the rating based on the adequacy of the approach roadway alignment. This item identifies those bridges which do not function properly or adequately due to the alignment of the approaches. It is not intended that the approach roadway alignment be compared to current standards but rather to the existing highway alignment. This concept differs from other appraisal evaluations. The establishment of set criteria to be used at all bridge sites is not appropriate for this item. The basic criteria are how the alignment of the roadway approaches to the bridge relate to the general highway alignment for the section of highway the bridge is on.

The approach roadway alignment will be rated intolerable (a code of 3) only if the horizontal or vertical curvature requires a substantial reduction in the vehicle operating speed from that on the highway section. A very minor speed reduction will be rated a 6, and when a speed reduction is not required, the appraisal code will be an 8.

For example, if the highway section requires a substantial speed reduction due to vertical or horizontal alignment, and the roadway approach to the bridge requires only a very minor additional speed reduction at the bridge, the appropriate code would be a 6. This concept shall be used at each bridge site.

Speed reductions necessary because of structure width and not alignment shall not be considered in evaluating this item.

(72) Approach Roadway Alignment Appraisal	
NBI Rating	Description
8	Good – No speed reduction required
6	Fair – Horizontal or Vertical curvature requires a very minor speed reduction
3	Intolerable – Horizontal or Vertical curvature requires a substantial reduction in vehicle operating speed

THIS PAGE IS INTENTIONALLY LEFT BLANK

Chapter 10 – Field Abbreviations





Chapter 10. Field Abbreviations

Term	Abbreviation	Comment
Abutment	ABUT	N ABUT = north abutment
Adjacent	ADJ	
Aluminum	ALUM	
Anchor	ANCH	
Approach	APPR	W APPR = west approach
Asphalt	ASPH	
Bearing	BRG	BRG1 = bearing #1
Beam Guard	BG	
Barrel	BRL	
Bottom	BOT	
Between	BTWN	
Column	C	C2 = column #2
Centerline	C/L	
Compression	COMP	
Concrete	CONC	
Connection	CONN	
Crack	CRK	CRKS = cracks; CRKD = cracked; CRKNG = cracking
Drip Edge	DE	
Delamination	DELAM	

Term	Abbreviation	Comment
Deterioration	DETER	
Diagonal	DIAG	
Diaphragm	DIAPH	
Diameter	DIA or ϕ	
Downstream	D/S	
East	E	
Efflorescence	EFFL	
Elevation	ELEV	
Exposed	EXP	
Exterior	EXT	
Extrusion	EXTR	
Floor beam	FB	FB4 = floor beam #4
Flange	FLG	
Freeze-thaw	F/T	referring to freeze-thaw damage
Fiber Reinforced Polymer	FRP	
Girder	G	G4 = girder #4
Ground Penetrating Radar	GPR	
Geosynthetic Reinforced Soil	GRS	

Term	Abbreviation	Comment
Hairline	H/L	H/L CRK = hairline crack
Horizontal	HOR	
Heavy	HVY	
Interior	INT	
Infrared scan	IR	
Joint	JT	
Loss of Section	LOS	
Mechanically Stabilized Earth	MSE	
North	N	
Northeast	NE	
Narrow	NRW	
Northwest	NW	
Pier	P	P2 = pier #2
Pre-stress	P/S	
Post tension	P/T	
Pier cap	PC	
Plate	PL	
Panel point	PP	
Parapet	PPT	
Pack rust	PR	

Term	Abbreviation	Comment
Polymer Modified Asphalt	PMA	
Quadrant	QUAD	
South	S	
Southeast	SE	
Shoulder	SHLDR	
Spall	SPL	
Span	SP	SP3 = span #3
Stringer	ST	ST1 = stringer #1
Stiffener	STIFF	
Southwest	SW	
Top	T	
Transverse	TRANS	
Typical	TYP	
Upstream	U/S	
Vertical	VERT	
Waterline	W/L	
West	W	
With	W/	

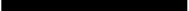
Concrete Cracks	
Crack Widths	
Hairline	<0.012" 
Narrow	0.012" up to 0.05"  
Medium	0.05" up to 0.1"  
Wide	>0.1" 