

**FULL SPAN SADDLE CONNECTION**

PREFERRED OPTION

- 3/4" GALVANIZED A325 OR A449 HEAVY HEX BOLT, NUT AND WASHER SNUG TIGHT ONLY, DO NOT OVER TIGHTEN
- "PD" = CHORD "OD" / 2 + 3/4"
- "PS" = CHORD "OD" + 1/16"

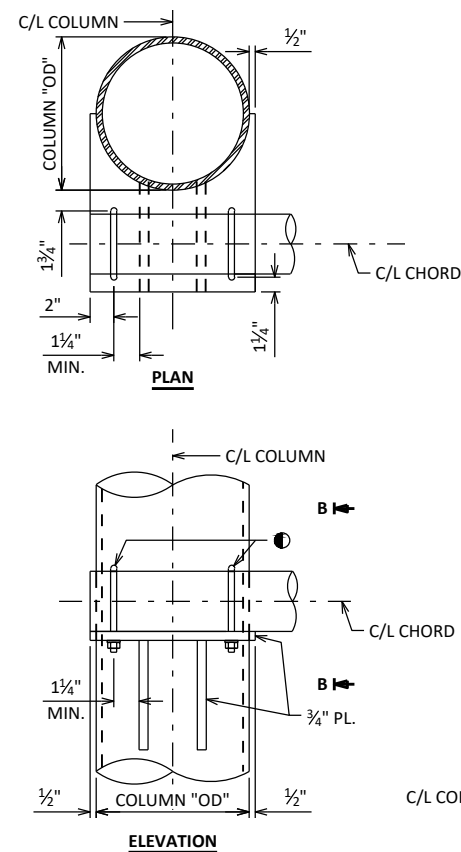

**FULL SPAN STIFFENED BEARING CONNECTION**

ALTERNATE 1

- MIN. (2) 1/2" MIN. GALVANIZED OR STAINLESS U-BOLT, LOCK NUT AND WASHER

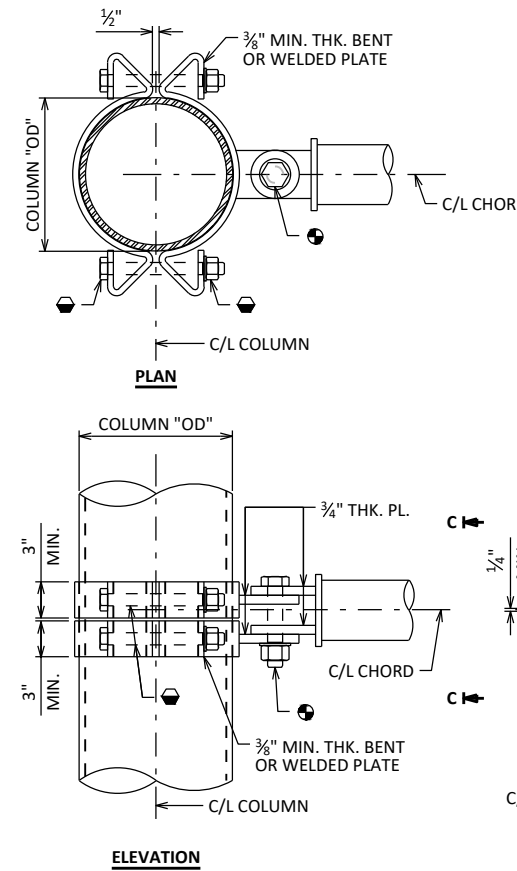

**FULL SPAN CLAMP CONNECTION**

ALTERNATE 2 - TAPERED COLUMNS ONLY

- 1 1/4" GALVANIZED A325 HEAVY HEX BOLT, NUT AND WASHER
- 1" GALVANIZED A325 HEAVY HEX BOLT, NUT AND WASHER

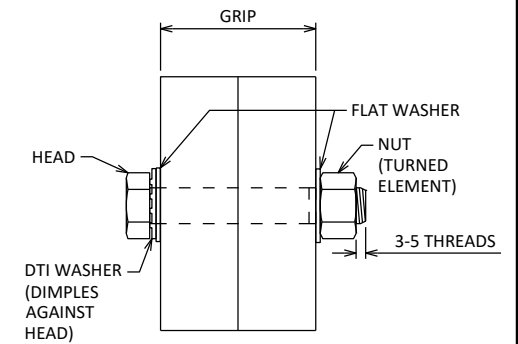

**RECOMMENDED BOLT DETAIL WITH DTI WASHER**

NUT IS TURNED ELEMENT

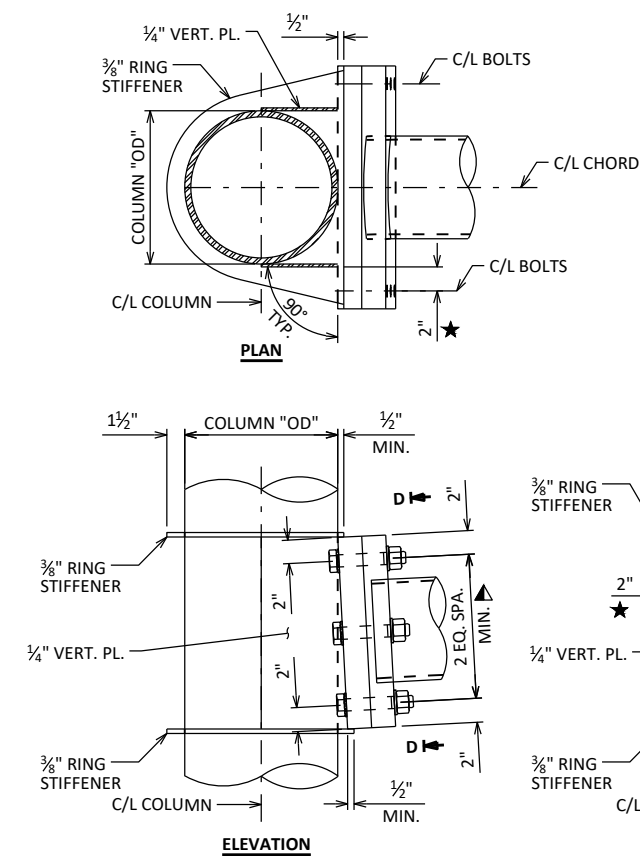

**CANTILEVER POST TO CHORD CONNECTION**

- MIN. (6) 1" GALVANIZED A325 HEAVY HEX BOLT, NUT, DTI WASHER AND WASHER
- MIN. DIMENSIONS MEASURED FROM EXT. FACE OF VERTICAL PLATE.

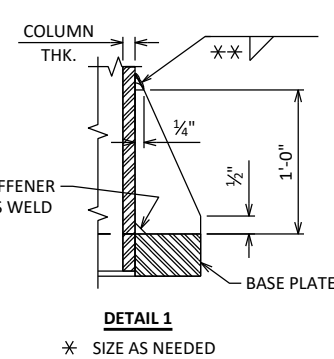

**DETAIL 1**

\* SIZE AS NEEDED

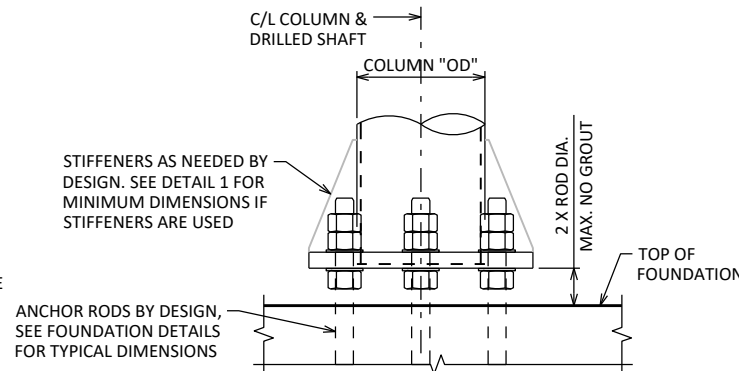

**PREFERRED BASE PLATE CONNECTION**

LOOKING AT F.F. OF STRUCTURE. ALTERNATE BASE PLATE DESIGNS ALLOWED.

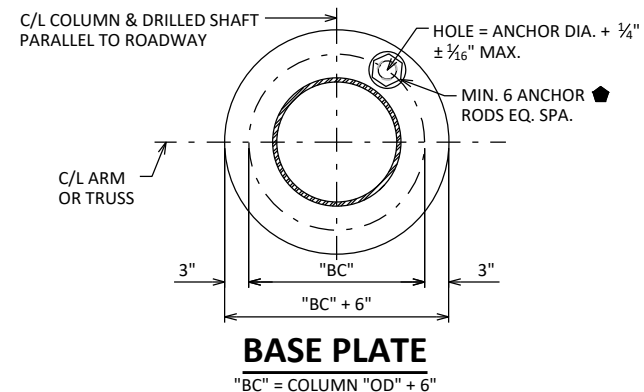

**BASE PLATE**

"BC" = COLUMN "OD" + 6"

- ANCHOR SIZE AND ORIENTATION TO BE VERIFIED WITH SHOP DRAWINGS.

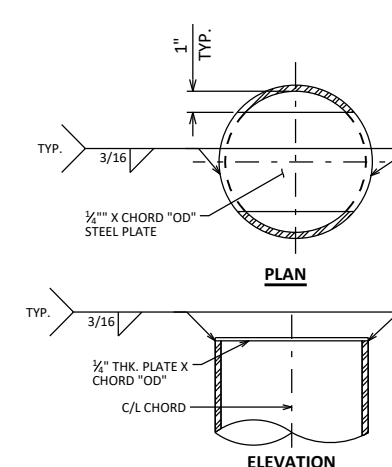

**CHORD CAP DETAIL**

CANTILEVERS ONLY

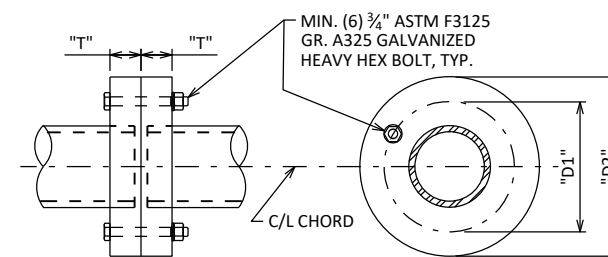

**CHORD SPLICE DETAIL**

"D1" = COLUMN "OD" + (1.5 x DB)  
 "D2" = COLUMN "OD" + (3 x DB)  
 "T" = (BY DESIGN)  
 DB = BOLT DIAMETER (BY DESIGN)

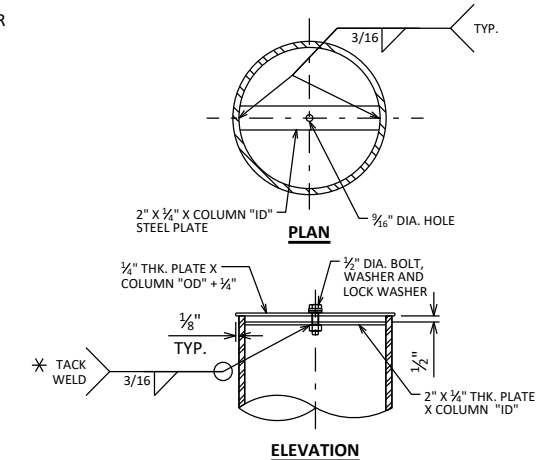

**TOWER CAP DETAIL**

- PLACE TACK WELD EVERY OTHER FLAT TO SECURE NUT. ALTERNATE: USE 1/2" THK. PL. AND DRILL AND TAP HOLE FOR BOLT.

**NOTES:**

MINIMUM VALUES SHOWN. ALL CONNECTIONS ARE TO BE DESIGNED FOR ACTUAL STRUCTURAL LOADS.

NO.	DATE	REVISION	BY
STATE OF WISCONSIN DEPARTMENT OF TRANSPORTATION STRUCTURES DESIGN SECTION			
<b>UPDATED: JAN. 2023</b>			
DRAWN BY BOS		PLANS CK'D BOS	
<b>MONOTUBE &amp; 2-CHORD TRUSS CONNECTIONS 1</b>		SHEET 1	

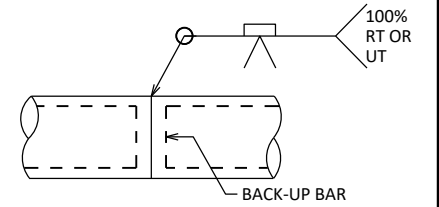

**CHORD SPLICE**

SEPARATE OPTIONAL SPLICE FROM GUSSET PLATES BY 6" MIN.

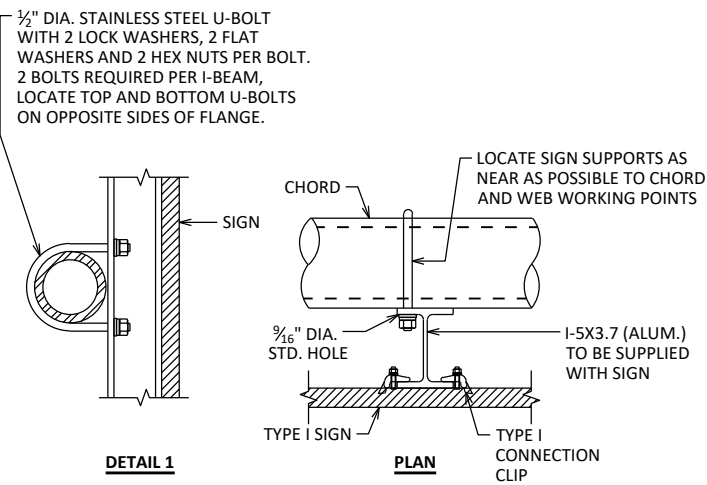

**2-CHORD TRUSS SIGN CONNECTION**

TYPE I SIGN PANEL SHOWN. SEE SIGN PLATE MANUAL A4-7A AND A4-7B FOR DETAILS. ALUMINUM I-5X3.7 I-BEAMS ARE TO BE SUPPLIED WITH SIGN PANEL, HARDWARE TO BE SUPPLIED BY THE CONTRACTOR.

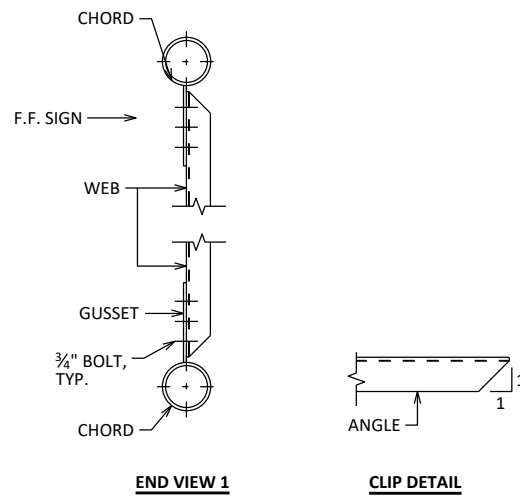

**TRUSS CONNECTION DETAILS**

MEMBER ORIENTATION FOR BOLTED CONNECTIONS SHOWN, WELDED CONNECTIONS SIMILAR

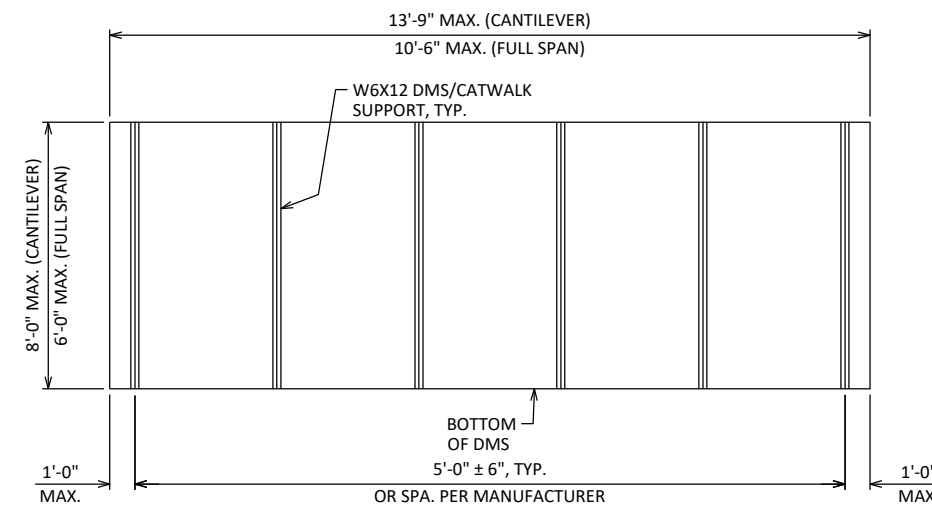

**DMS MOUNTING POST DETAIL**

POST SPACING MAY BE ADJUSTED AS REQUIRED IF SPACING CONFLICTS WITH GUSSET PLATES OF TRUSS WITHIN TOLERANCES NOTED.

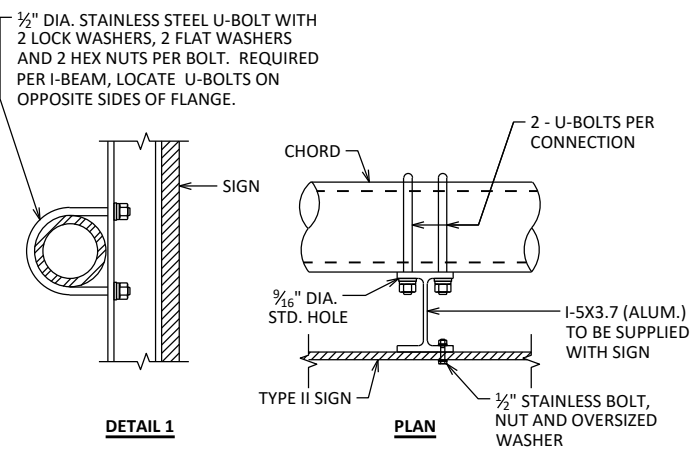

**MONOTUBE SIGN CONNECTION**

TYPE II SIGN PANEL SHOWN. SEE SIGN PLATE MANUAL A4-7A AND A4-7B FOR DETAILS. ALUMINUM I-5X3.7 I-BEAMS ARE TO BE SUPPLIED WITH SIGN PANEL, HARDWARE TO BE SUPPLIED BY THE CONTRACTOR.

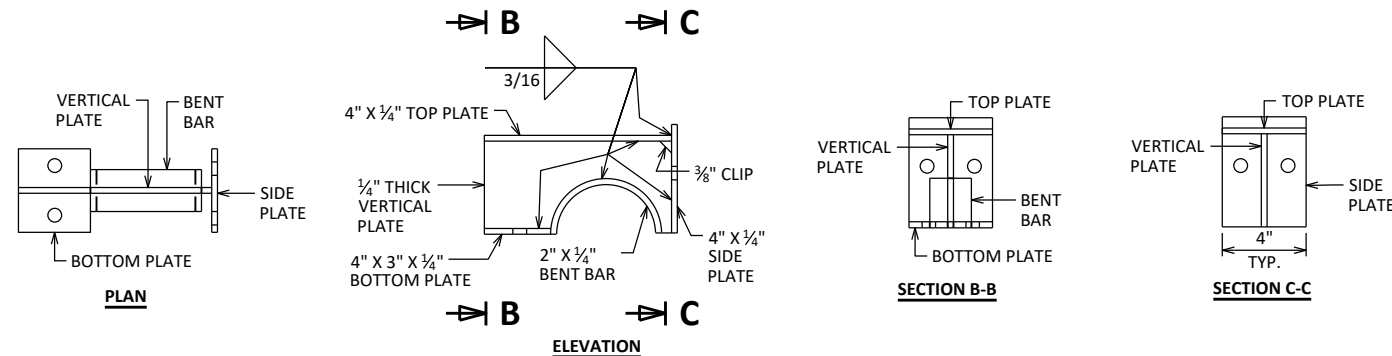

**DMS WELDED PLATE CONNECTION DETAILS**

TOP HALF OF BRACKET SHOWN, BOTTOM HALF SIMILAR.

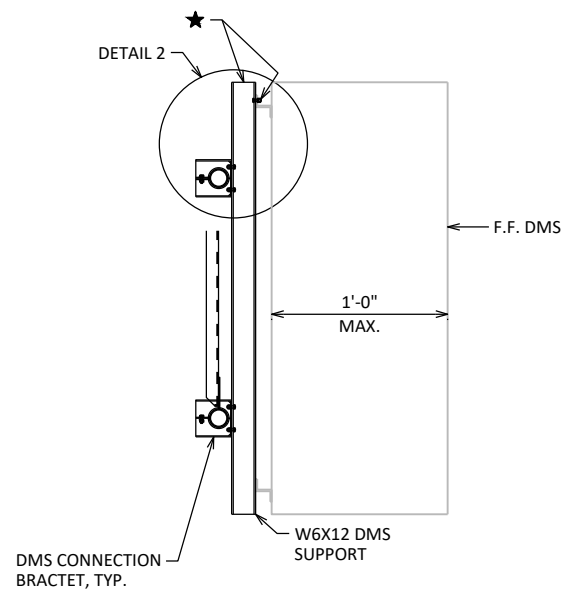

**SECTION THRU TRUSS - DMS**

FOR DMS/CATWALK CONNECTIONS

★ W6X12 SUPPORTS AND HARDWARE ARE TO BE SUPPLIED BY THE CONTRACTOR. 1/2" STAINLESS BOLT, NUT, WASHER AND LOCK WASHER REQUIRED, 4 PER W6X12

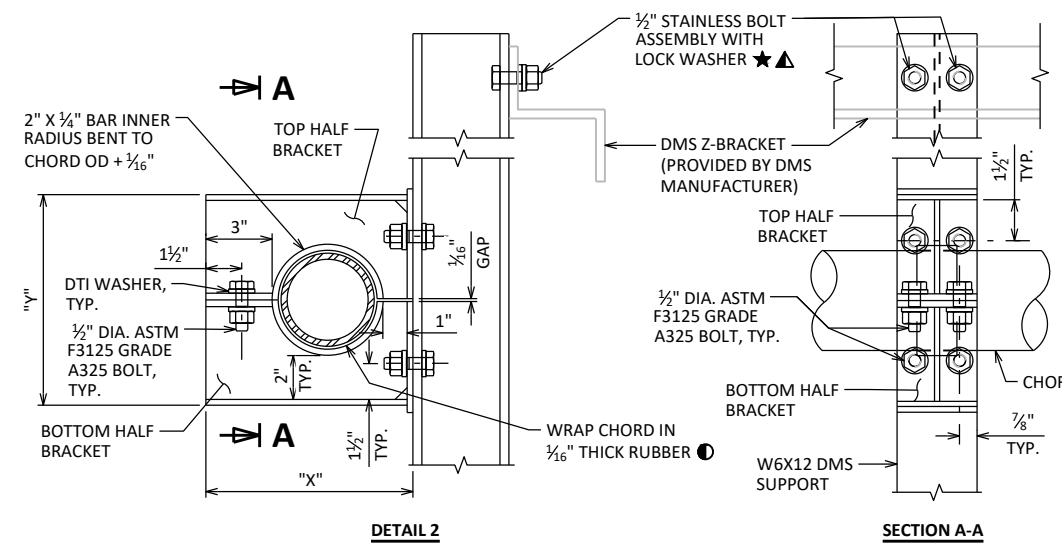

CHORD "OD"	"X"	"Y"
"OD"	"OD" + 4 3/16"	"OD" + 5 1/16"

**TYPICAL DMS CONNECTION**

- NEOPRENE, GRADE 45±5, OTHERWISE MEETING THE REQUIREMENTS OF STD. SPEC. 506.2.6.1
- ▲ IF DMS CONNECTION BRACKET IS USED WITH A TYPE II SIGN PANEL, THE BOLT HOLE MUST BE GALVANIZED AND A STAINLESS WASHER USED BETWEEN THE I-BEAM AND SIGN PANEL.

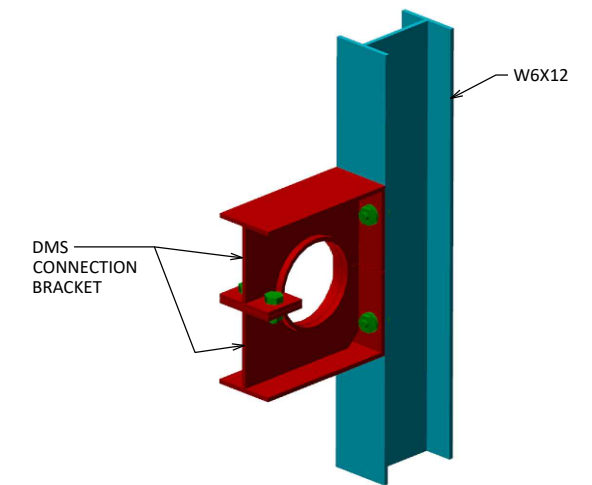

**3-D VIEW OF DMS CONNECTION**

CHORD NOT SHOW FOR CLARITY

NO.	DATE	REVISION	BY
STATE OF WISCONSIN DEPARTMENT OF TRANSPORTATION STRUCTURES DESIGN SECTION			
<b>UPDATED: JAN. 2023</b>			
DRAWN BY BOS		PLANS CK'D BOS	
<b>MONOTUBE &amp; 2-CHORD TRUSS CONNECTIONS 2</b>		SHEET II	

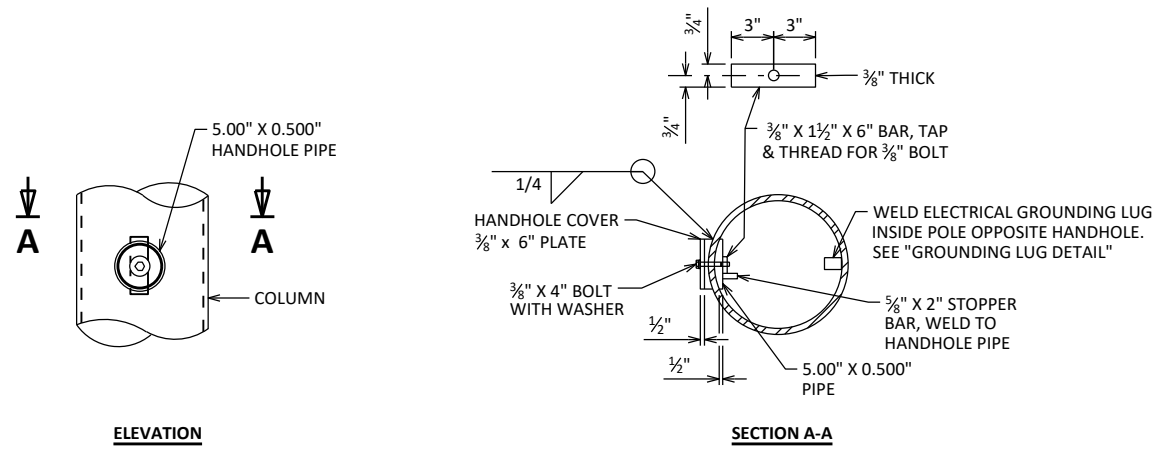

**HANDHOLE DETAILS**

HANDHOLES SHALL BE LOCATED IN ONE COLUMN OF THE SIGN BRIDGE STRUCTURE IF ELECTRICALLY OPERATED DEVICES ARE INSTALLED ON/IN THE STRUCTURE. COLUMNS WITH HANDHOLES SHALL BE NEAR THE ELECTRICAL SERVICE. THE CONTRACTOR SHALL VERIFY THE LOCATION OF THE ELECTRICAL SERVICE ENTRANCE WITH THE REGION TRAFFIC SECTION PRIOR TO FABRICATION OF THE SIGN BRIDGE COLUMNS AND MEMBERS. CONDUIT (AS REQ'D.) SHALL BE LOCATED, PLACED AND SIZED AS SHOWN ON THE ELECTRICAL PLAN DETAIL SHEETS.

UNLESS OTHERWISE NOTED, ALL HANDHOLE ELEMENTS TO BE GALVANIZED PER THE WISDOT STANDARD SPECIFICATIONS.

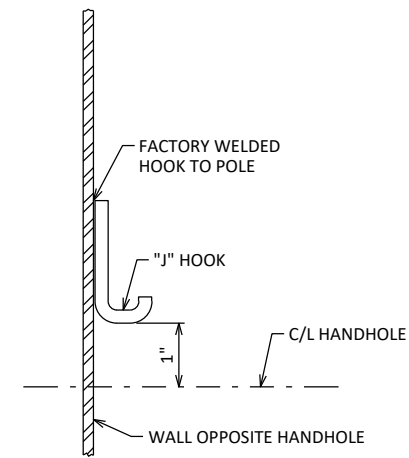

**TYPICAL "J" HOOK LOCATION**

THE "J" HOOK SHALL BE FACTORY WELDED TO THE INSIDE OF THE COLUMN CONTAINING ELECTRICAL WIRING. THE "J" HOOK SHALL BE ATTACHED ABOVE THE CENTERLINE OF THE UPPER HANDHOLE AND MOUNTED DIRECTLY OPPOSITE THE HANDHOLE AS SHOWN IN THE DRAWING.

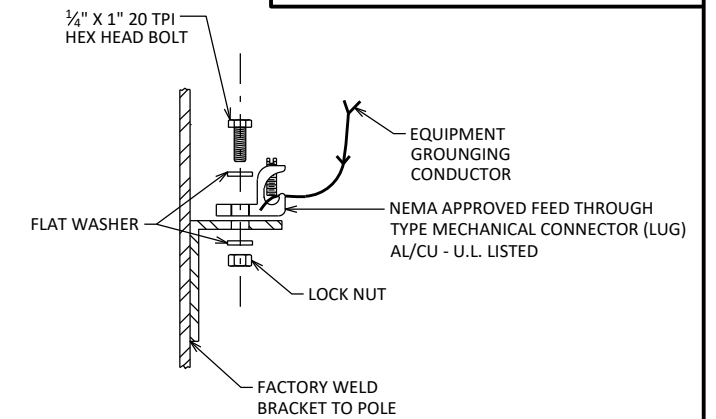

**GROUNDING LUG DETAIL**

NUT, BOLT AND WASHERS SHALL BE STAINLESS STEEL

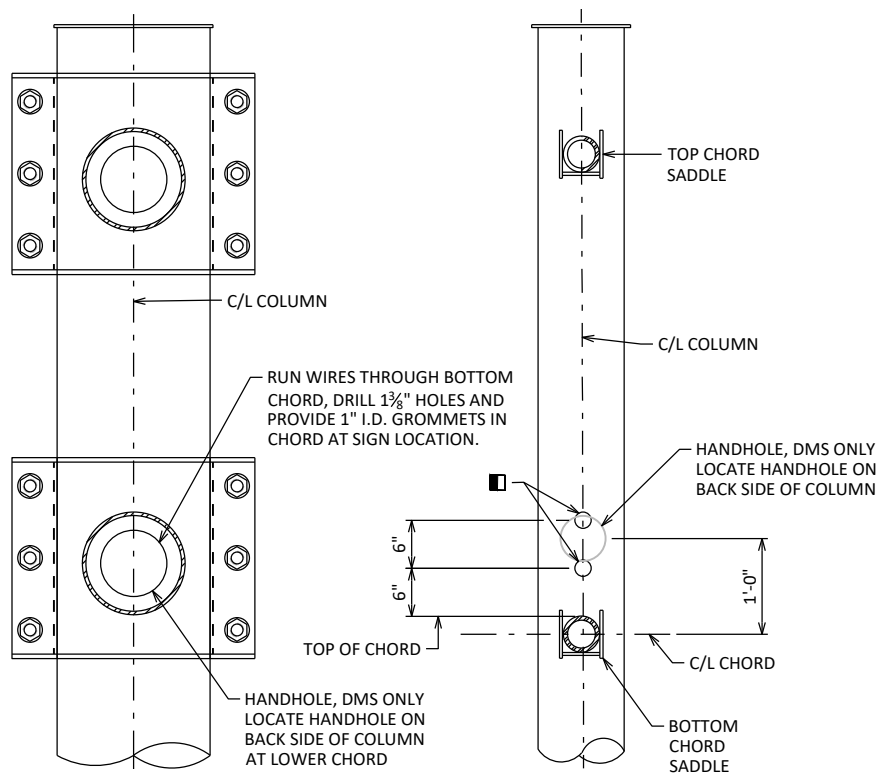

**CONDUIT HOLE LOCATIONS**

2" HOLE WITH STANDARD PIPE THREADS, USE THREADED CONDUIT PLUG FOR UNUSED HOLES

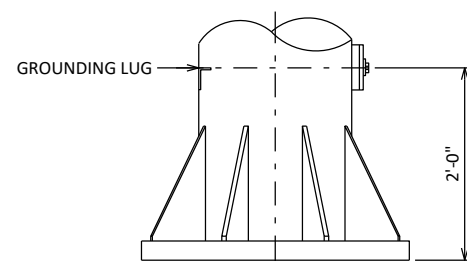

**GROUNDING LUG LOCATION**

LOOKING AT THE F.F. OF STRUCTURE

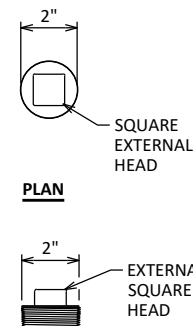

**CONDUIT PLUG DETAILS**

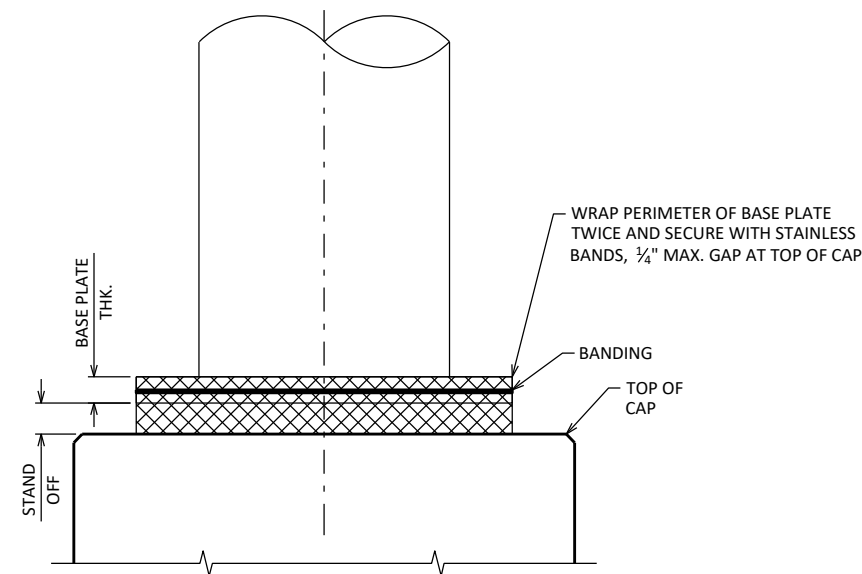

**RODENT SCREEN**

ONLY REQ'D WHEN ELECTRICAL DEVICES ARE PRESENT ANCHOR RODS NOT SHOWN

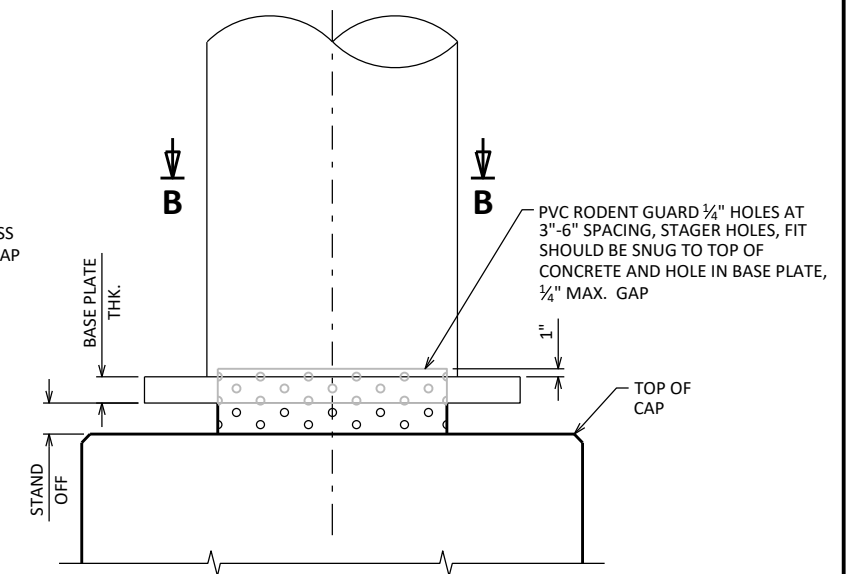

**RODENT SCREEN - ALTERNATE**

ONLY REQ'D WHEN ELECTRICAL DEVICES ARE PRESENT ANCHOR RODS NOT SHOWN

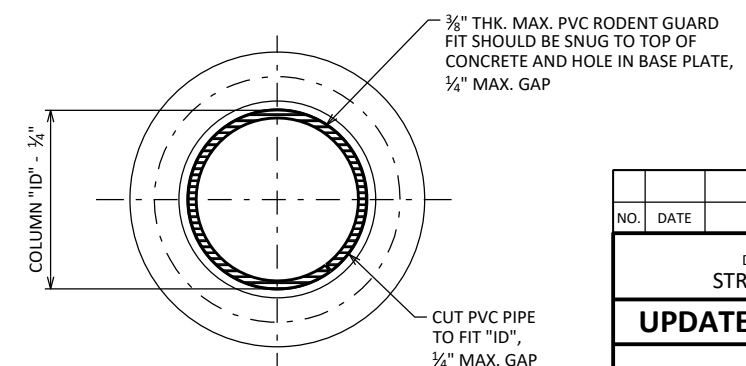

**SECTION B-B**

NO.	DATE	REVISION	BY
STATE OF WISCONSIN DEPARTMENT OF TRANSPORTATION STRUCTURES DESIGN SECTION			
<b>UPDATED: JAN. 2023</b>			
DRAWN BY BOS		PLANS CK'D BOS	
<b>MONOTUBE &amp; 2-CHORD TRUSS ELECTRICAL DETAILS</b>			SHEET III

NOTE: THE FIRST OR FIRST TWO DIGITS OF THE BAR MARK SIGNIFIES THE BAR SIZE.

**BILL OF BARS**

**STANDARD TYPE MFI**

BAR MARK	COAT	NO. REQ'D.	LENGTH	BENT	BAR SERIES	LOCATION
A801		6	11'-8"			DRILLED SHAFT - VERTICAL
A402		13	5'-10"	X		DRILLED SHAFT - HORIZONTAL

**STANDARD TYPE MFII**

BAR MARK	COAT	NO. REQ'D.	LENGTH	BENT	BAR SERIES	LOCATION
A801		10	12'-8"			DRILLED SHAFT - VERTICAL
A402		14	9'-4"	X		DRILLED SHAFT - HORIZONTAL

**STANDARD TYPES MCI/MCII/TFI**

BAR MARK	COAT	NO. REQ'D.	LENGTH	BENT	BAR SERIES	LOCATION
A901		10	16'-8"			DRILLED SHAFT - VERTICAL
A402		18	9'-4"	X		DRILLED SHAFT - HORIZONTAL

**STANDARD TYPE TCI**

BAR MARK	COAT	NO. REQ'D.	LENGTH	BENT	BAR SERIES	LOCATION
A901		14	17'-8"			DRILLED SHAFT - VERTICAL
A402		19	10'-10"	X		DRILLED SHAFT - HORIZONTAL

**STANDARD TYPE TFII**

BAR MARK	COAT	NO. REQ'D.	LENGTH	BENT	BAR SERIES	LOCATION
A1001		14	19'-8"			DRILLED SHAFT - VERTICAL
A402		21	10'-10"	X		DRILLED SHAFT - HORIZONTAL

**STANDARD TYPES MCIII/TCII/TFIII**

BAR MARK	COAT	NO. REQ'D.	LENGTH	BENT	BAR SERIES	LOCATION
A1001		14	17'-8"			DRILLED SHAFT - VERTICAL
A402		19	12'-5"	X		DRILLED SHAFT - HORIZONTAL

**STANDARD TYPES MCIV/TFIV**

BAR MARK	COAT	NO. REQ'D.	LENGTH	BENT	BAR SERIES	LOCATION
A1001		14	22'-8"			DRILLED SHAFT - VERTICAL
A402		24	12'-5"	X		DRILLED SHAFT - HORIZONTAL

**STANDARD TYPE TCIII**

BAR MARK	COAT	NO. REQ'D.	LENGTH	BENT	BAR SERIES	LOCATION
A1001		14	22'-8"			DRILLED SHAFT - VERTICAL
A402		24	14'-0"	X		DRILLED SHAFT - HORIZONTAL

**STANDARD TYPE TCIV**

BAR MARK	COAT	NO. REQ'D.	LENGTH	BENT	BAR SERIES	LOCATION
A1001		14	27'-8"			DRILLED SHAFT - VERTICAL
A402		29	14'-0"	X		DRILLED SHAFT - HORIZONTAL

\*\*\* VALUES IN BAR TABLES ARE FOR A SINGLE FOUNDATION ONLY. MULTIPLY BY 2 FOR FULL SPAN STRUCTURES.

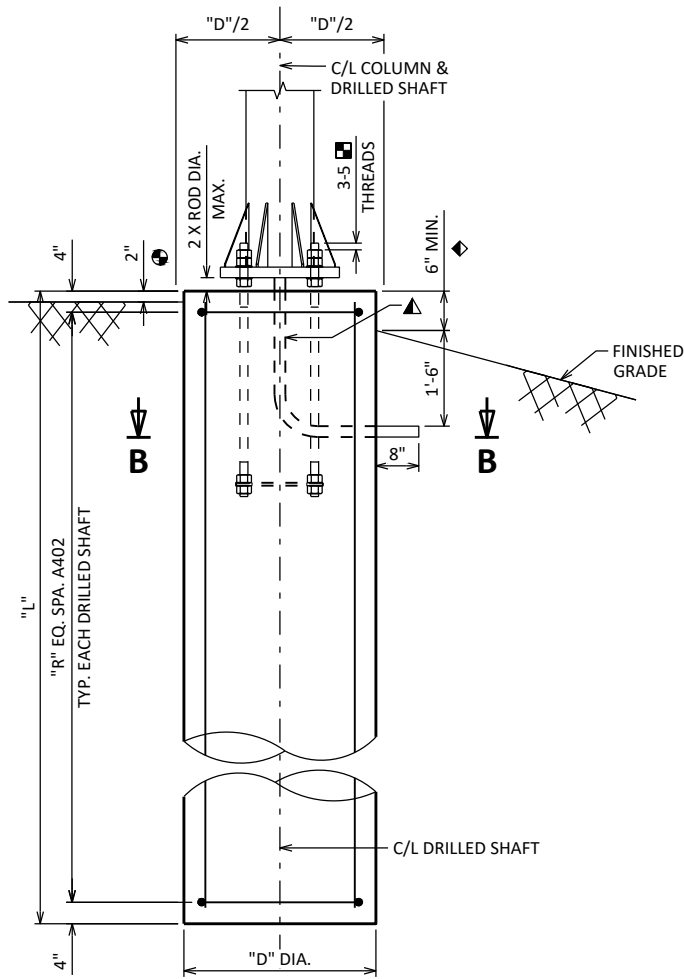

**ELEVATION**

• TYPICAL FOR DRILLED SHAFT FOOTINGS INSTALLED ADJACENT TO SIDEWALKS OR BEHIND CURB AND GUTTER ON LOW SPEED ROADS. TOP OF SHAFT SHALL BE FLUSH IF SURROUNDED BY CONCRETE AND 2" ABOVE FINISHED GRADE FOR ALL OTHER SURFACES.

♦ TYPICAL FOR EACH DRILLED SHAFT FOOTING INSTALLED ADJACENT TO ROADWAY FACILITIES OR ON SIDE SLOPES WITHIN CLEAR ZONE. BARRIER OR BEAMGUARD MAY BE REQUIRED.

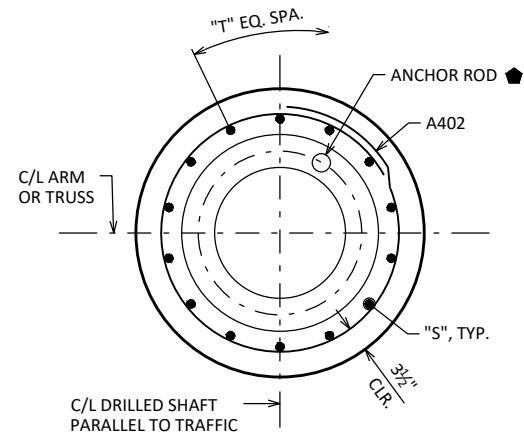

**SECTION B-B**

TYPICAL FOR EACH DRILLED SHAFT FOOTING

**FOUNDATION DIMENSION DATA**

STANDARD DESIGN TYPE	FOUNDATION DIMENSIONS					
	"D"	"L"	"R"	"S"	"T"	"BC" MAX.
MFI	2'-0"	12'-0"	12	A801	6	1'-0"
MFII	2'-6"	13'-0"	13	A801	10	1'-5"
MCI/MCII/TFI	2'-6"	17'-0"	17	A801	10	1'-5"
TCI	3'-0"	18'-0"	18	A801	14	1'-10"
TFII	3'-0"	20'-0"	20	A801	14	1'-10"
MCIII/TCII/TFIII	3'-6"	18'-0"	18	A901	14	2'-4"
MCIV/TFIV	3'-6"	23'-0"	23	A901	14	2'-4"
TCIII	4'-0"	23'-0"	23	A1001	14	2'-10"
TCIV	4'-0"	28'-0"	28	A1001	14	2'-10"

**ESTIMATED QUANTITIES - FOUNDATION**

STANDARD DESIGN TYPE	CONCRETE MASONRY (CY)	STEEL REINFORCEMENT HS (LBS)	FOUNDATION DRILLING (DIA.) (LF)				
			24"	30"	36"	42"	48"
MFI	2	240	12	---	---	---	---
MFII	3	410	88	13	---	---	---
MCI/MCII/TFI	4	540	---	17	---	---	---
TCI	5	780	---	---	18	---	---
TFII	6	860	---	---	20	---	---
MCIII/TCII/TFIII	7	970	---	---	---	18	---
MCIV/TFIV	9	1,250	---	---	---	23	---
TCIII	11	1,560	---	---	---	---	23
TCIV	13	1,900	---	---	---	---	28

\*\*\* QUANTITIES ARE FOR INFORMATION ONLY AND ARE BASED ON A SINGLE DRILLED SHAFT. MULTIPLY BY 2 FOR FULL SPAN STRUCTURES.

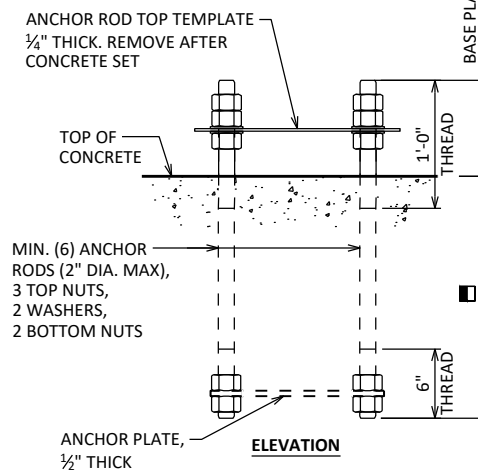

**ANCHOR ROD ASSEMBLY DETAILS**

■ ANCHOR RODS PER ASSEMBLY TO BE DESIGNED BY CONTRACTOR AND SHOWN ON SHOP DRAWINGS. SHOW DIAMETER, NUMBER, ORIENTATION AND EMBEDMENT OF ANCHOR RODS.

CENTER ANCHOR ROD ASSEMBLY AND ENSURE ASSEMBLY IS PLUMB. MAINTAIN ANCHOR ROD PROJECTION ABOVE TOP OF CONCRETE AS DETAILED. ANCHOR ROD ASSEMBLY SHALL BE RIGIDLY SECURED IN POSITION DURING AND AFTER CONCRETE PLACEMENT. DO NOT WELD THE ANCHORS.

ANCHOR DIAMETER	MAX. STICK OUT "X"
1"	5"
1 1/4"	6"
1 1/2"	7"
1 3/4"	8"
2"	9"

• ADD BASE PLATE THICKNESS TO VALUE SHOWN FOR MAX. STICK OUT DIMENSION. CONTRACTOR TO COORDINATE WITH FABRICATOR FOR PROPER ANCHOR PLACEMENT.

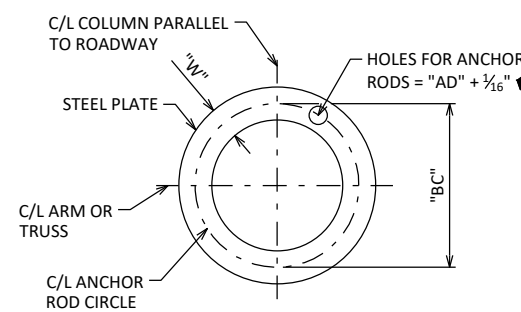

**ANCHOR PLATE & TOP TEMPLATE**

• ANCHOR SIZE AND POSITION TO BE VERIFIED WITH SHOP DRAWINGS.

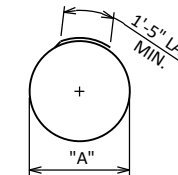

**A402**

**LEGEND**

■ ANCHOR ROD STICK OUT IN FINAL CONDITION. EXCESSIVE STICK OUT BEYOND DIMENSION SHOWN TO BE CUT OFF AFTER PLACING STRUCTURE. ANCHORS TO BE ULTRASONIC TESTED TO DETERMINE EMBEDDED LENGTH MEETS REQUIREMENTS PRIOR TO CUTTING. NOTE REMAINING LENGTH ON AS-BUILT.

▲ 2 - 2" DIA. NON-METALLIC CONDUITS. INSTALL ONLY WITH DMS. EXTEND CONDUITS AS SHOWN AND CAP OR SEAL EACH END WITH A SUITABLE REMOVABLE PLUG. PLACE CONDUITS UNDER COLUMN ADJACENT TO DMS. CONDUITS INCIDENTAL TO THE FOUNDATION BID ITEMS.

NO.	DATE	REVISION	BY
STATE OF WISCONSIN DEPARTMENT OF TRANSPORTATION STRUCTURES DESIGN SECTION			
<b>UPDATED: JUNE 2023</b>			
DRAWN BY		BOS	PLANS CK'D BOS
<b>MONOTUBE &amp; 2-CHORD TRUSS FOUNDATIONS</b>			SHEET IV