

BROKEN RIB
 FORMLINER THICKNESS = $3" \pm 1/2"$
 WIDTH = $2" \pm 1/2"$
 MAX. RELIEF = $2" \pm 1/2"$

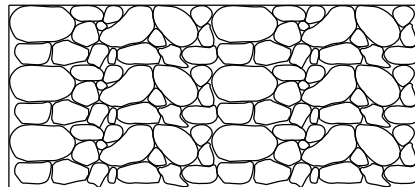

FIELD STONE - RANDOM
 FORMLINER THICKNESS = $3/2"$
 SIZES BETWEEN 6" & 24"
 MAX. RELIEF = $2/2"$

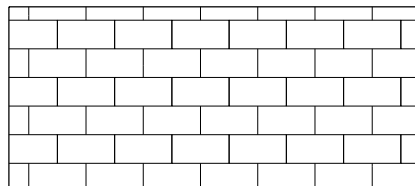

RECTANGULAR BRICK
 FORMLINER THICKNESS = 2"
 SIZE = VARIES
 MAX. RELIEF = 1"

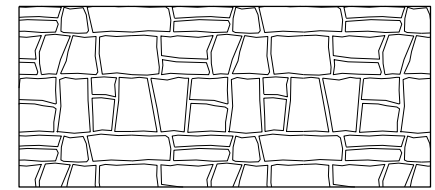

RUSTIC ASHLAR
 FORMLINER THICKNESS = 3"
 SIZE = 8" TO 32"
 MAX. RELIEF = 2"

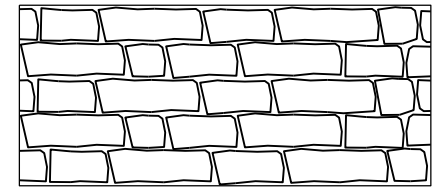

RECTANGULAR CUT STONE
 FORMLINER THICKNESS = 4" TO $5/2"$
 COURSE HEIGHT = $\pm 2"$
 MAX. RELIEF = 3" TO $4/2"$

WARNING
 FORMLINER SHOWN ON THIS STANDARD IS A
 NON-PARTICIPATING ITEM (CSS).

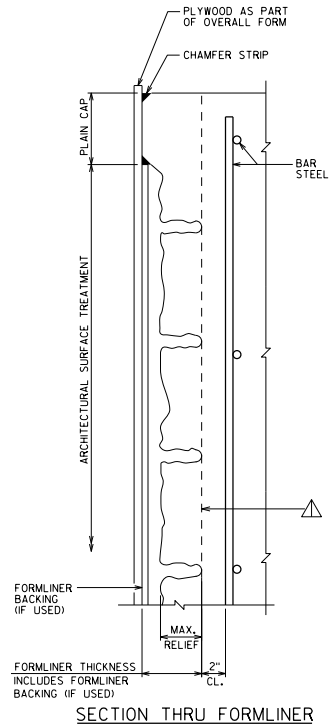

△ STRUCTURAL CONCRETE CAN ONLY BE ASSUMED TO THIS LINE. PROVIDE ADDITIONAL STRUCTURE SIZE AS NECESSARY TO MAINTAIN MINIMUM FULL STRUCTURAL CONCRETE DIMENSIONS AS INDICATED ON THE STANDARDS.

RETAINING WALL NOTES

FORMLINER COURSING ON RETAINING WALLS SHALL BE LEVEL

ABUTMENT NOTES

FORMLINER COURSING ON ABUTMENTS AND WINGS SHALL BE LEVEL.

THE FORMLINER COURSING ON THE WINGS SHALL BE VERTICALLY ALIGNED WITH THE FORMLINER COURSING ON THE FRONT OF THE ABUTMENT.

THE FORMLINER PATTERN SHALL BE CONTINUOUS ACROSS CONSTRUCTION JOINTS.

WRAPAROUND/MATCH FORMLINER PATTERN AT CORNERS.

PIER NOTES

FORMLINER COURSING ON PIERS SHALL BE LEVEL.

THE FORMLINER COURSING ON ALL FACES OF EACH COLUMN SHALL BE VERTICALLY ALIGNED.

SPACE ADJACENT PORTIONS OF FORMLINER ON SLOPED FACE SO THAT COURSING IS ALIGNED VERTICALLY WITH COURSING ON VERTICAL FACE.

THE FORMLINER PATTERN SHALL BE CONTINUOUS ACROSS CONSTRUCTION JOINTS.

WRAPAROUND/MATCH FORMLINER PATTERN AT CORNERS.

PARAPET NOTES

FORMLINER COURSING ON PARAPETS SHALL BE PARALLEL TO TOP OF PARAPET.

FORMLINER DETAILS	
	BUREAU OF STRUCTURES
APPROVED: <i>Laura Shadewald</i>	DATE: 7-16

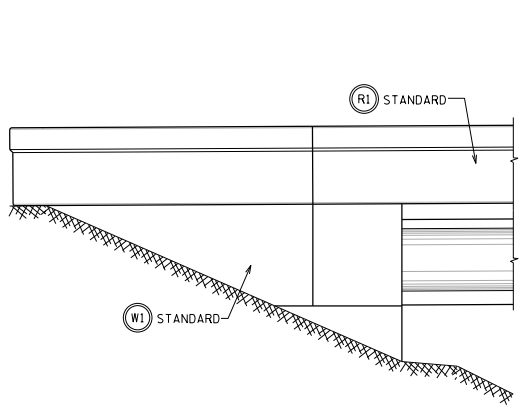

TYPE I

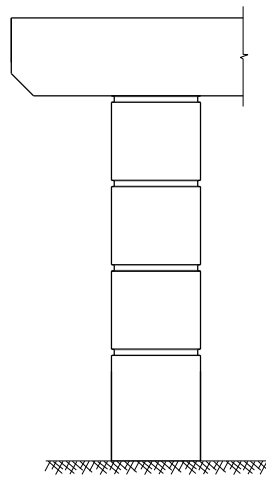

P1 SINGLE RUSTICATION LINES

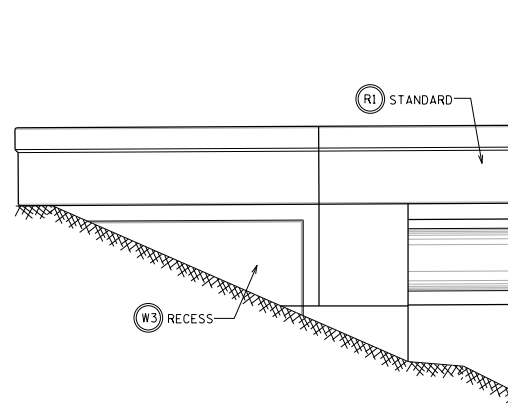

TYPE III

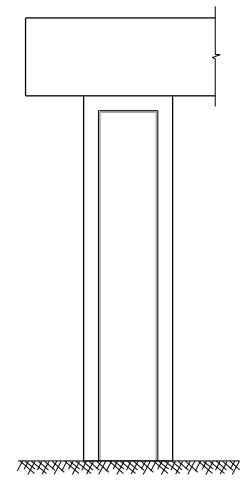

P3 RECESSED PANEL

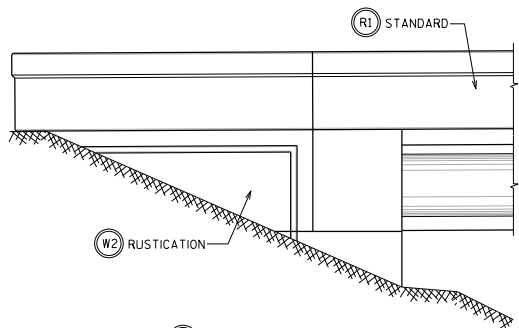

TYPE II

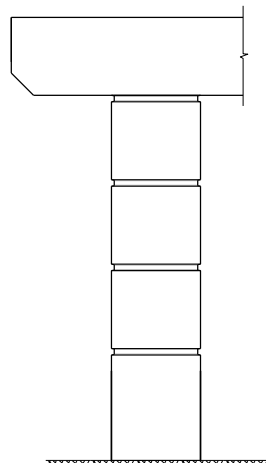

P1 SINGLE RUSTICATION LINES

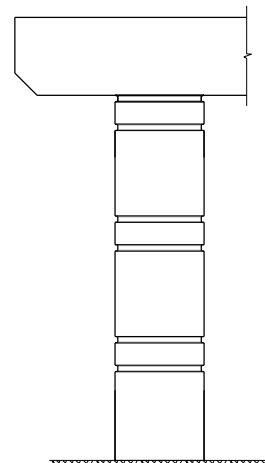

P2 DOUBLE RUSTICATION LINES

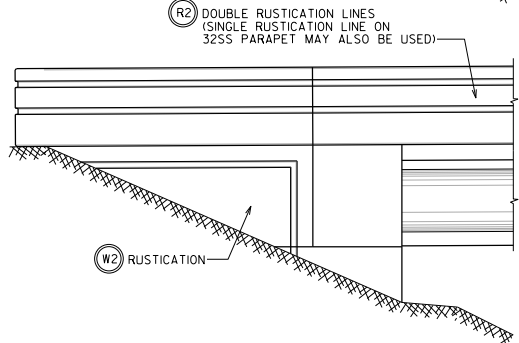

DESIGNER NOTES

THE THREE TYPES SHOWN ARE PREFERRED AESTHETIC CONCEPTS FOR WISDOT PROJECTS, WHEN USED WITHOUT STAINING, COSTS ARE INCIDENTAL TO "CONCRETE MASONRY BRIDGES" AND NOT SUBJECT TO CSS FUNDING.

ONLY THE CHOICE OF PARAPET, WING AND PIER DETAILS SHOWN FOR A GIVEN TYPE SHOULD BE USED FOR THAT TYPE.

WINGS PARALLEL TO CENTERLINE OF ABUTMENT (ELEPHANT EAR) ARE TO BE PLAIN (TYPE I).

SEE STANDARDS 4.04 AND 4.05 FOR ADDITIONAL DETAILS.

SEE BRIDGE MANUAL SECTION 4.9 FOR LOCATION OF USE AND RENDERINGS.

AESTHETIC CONCEPTS WITHOUT PEDESTRIAN ACCOMMODATIONS	
	BUREAU OF STRUCTURES
APPROVED: <i>Laura Shadewald</i>	DATE: 7-22

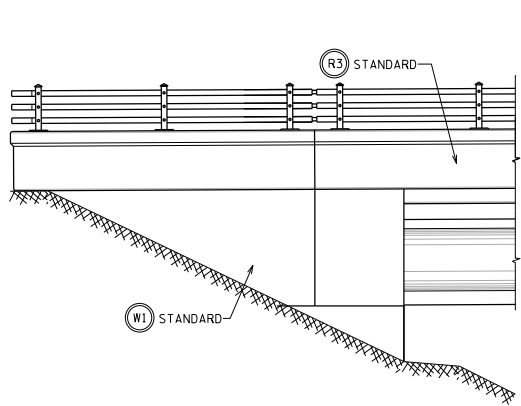

TYPE I

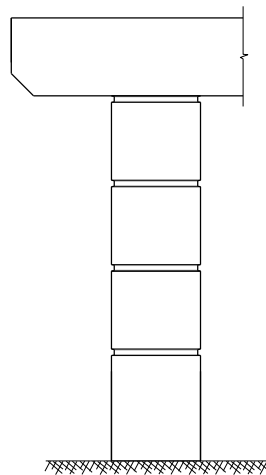

(P1) SINGLE RUSTICATION LINES

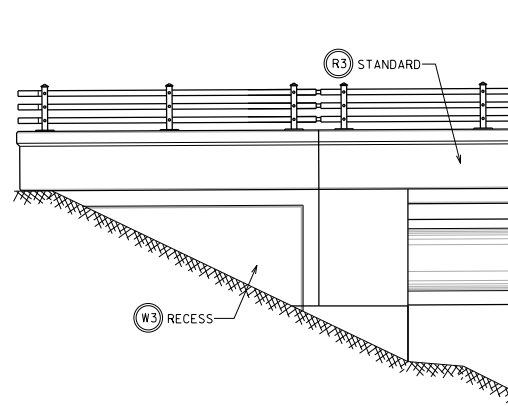

TYPE III

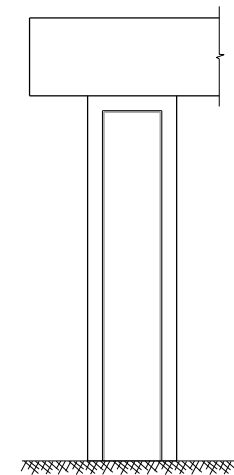

(P3) RECESSED PANEL

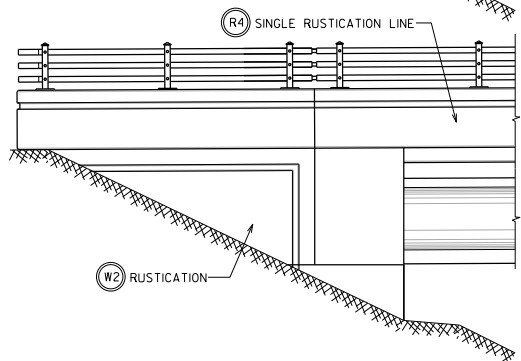
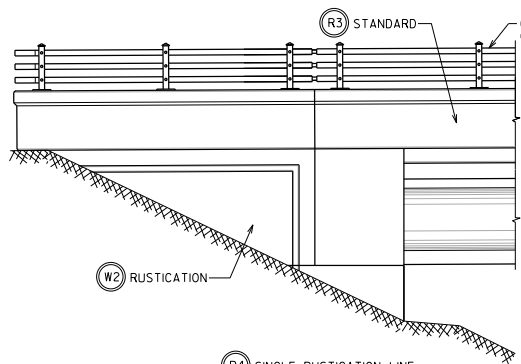

TYPE II

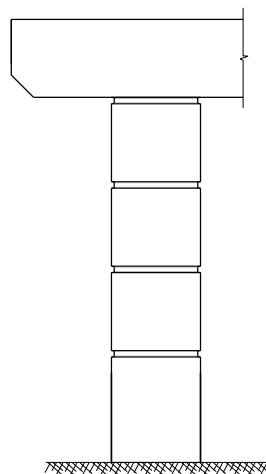

(P1) SINGLE RUSTICATION LINES

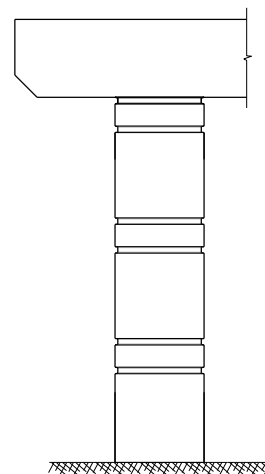

(P2) DOUBLE RUSTICATION LINES

COMBINATION RAILING TYPE '3T'
(SEE 'DESIGNER NOTES')

DESIGNER NOTES

THE THREE TYPES SHOWN ARE PREFERRED AESTHETIC CONCEPTS FOR WISDOT PROJECTS. WHEN USED WITHOUT STAINING, COSTS ARE INCIDENTAL TO "CONCRETE MASONRY BRIDGES" AND NOT SUBJECT TO CSS FUNDING.

ONLY THE CHOICE OF PARAPET, WING AND PIER DETAILS SHOWN FOR A GIVEN TYPE SHOULD BE USED FOR THAT TYPE.

WINGS PARALLEL TO CENTERLINE OF ABUTMENT (ELEPHANT EAR) ARE TO BE PLAIN (TYPE I).

IN LIEU OF THE 'COMBINATION RAILING TYPE '3T'' SHOWN, CHAIN LINK FENCING MAY BE USED. SEE STANDARD 4.04 FOR DETAILS.

SEE STANDARDS 4.04 AND 4.05 FOR ADDITIONAL DETAILS.

SEE BRIDGE MANUAL SECTION 4.9 FOR LOCATION OF USE AND RENDERINGS.

AESTHETIC CONCEPTS WITH PEDESTRIAN ACCOMMODATIONS



APPROVED: *Laura Shadewald* DATE: 7-22

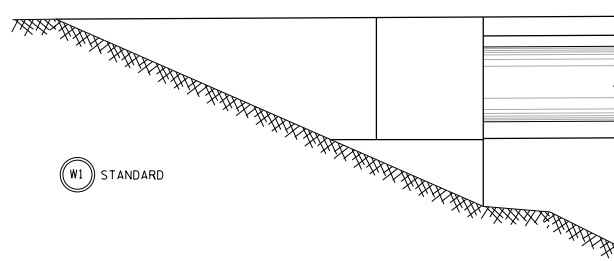

W1 STANDARD

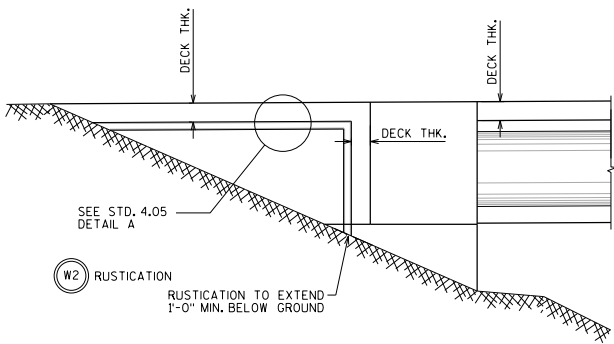

W2 RUSTICATION
RUSTICATION TO EXTEND
1'-0" MIN. BELOW GROUND

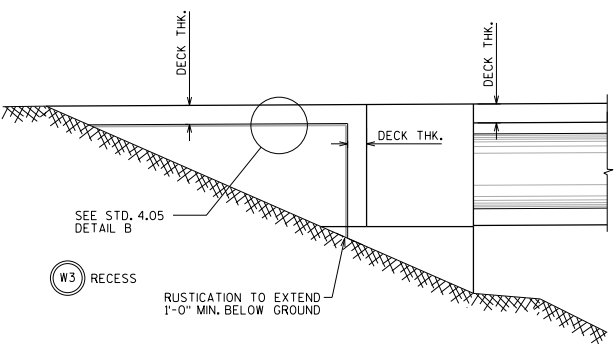

W3 RECESS
RUSTICATION TO EXTEND
1'-0" MIN. BELOW GROUND

WING OPTIONS

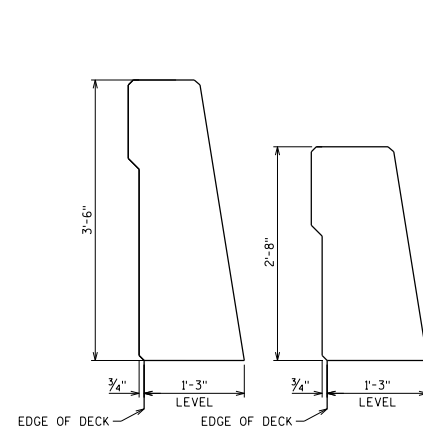

R1 STANDARD
SEE STD. 30.32 'SINGLE SLOPE
PARAPET 42SS' OR STD. 30.30
'SINGLE SLOPE PARAPET 32SS' FOR
DETAILS

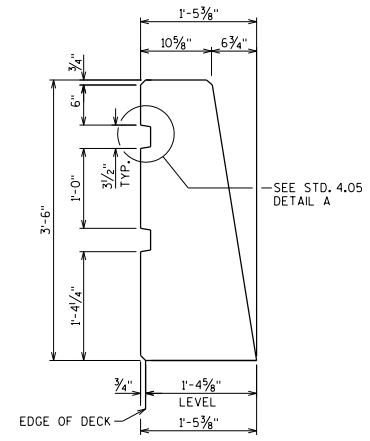

R2 DOUBLE RUSTICATION LINES
MODIFIED 'SINGLE SLOPE PARAPET 42SS'
(AREA = 4.01 SF, WEIGHT = 602 LB/FT.)

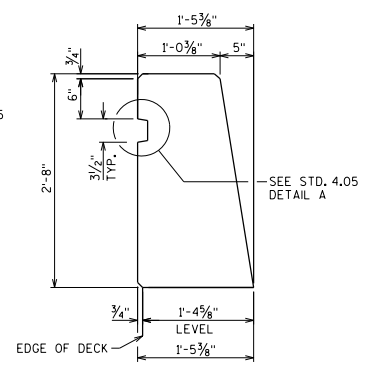

R2 SINGLE RUSTICATION LINES
MODIFIED 'SINGLE SLOPE PARAPET 32SS'
(AREA = 3.25 SF, WEIGHT = 488 LB/FT.)

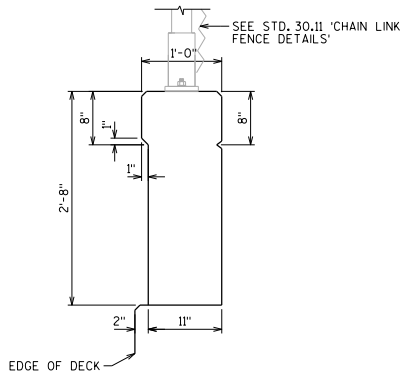

R3 STANDARD
SEE STD. 30.07 'VERTICAL FACE PARAPET 'A'
FOR DETAILS

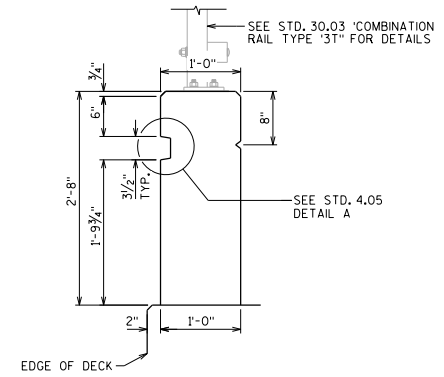

R4 SINGLE RUSTICATION LINES
MODIFIED 'VERTICAL FACE PARAPET 'A'
(AREA = 2.63 SF, WEIGHT = 395 LB/FT.)
SEE STD. 30.07 'VERTICAL FACE PARAPET 'A'
FOR DETAILS

PARAPET OPTIONS

DESIGNER NOTES
WINGS PARALLEL TO CENTERLINE OF ABUTMENT
(ELEPHANT EAR) ARE TO BE PLAIN (TYPE I).

WING & PARAPET AESTHETIC DETAILS	
	BUREAU OF STRUCTURES
APPROVED: <i>Laura Shadewald</i>	DATE: 1-19

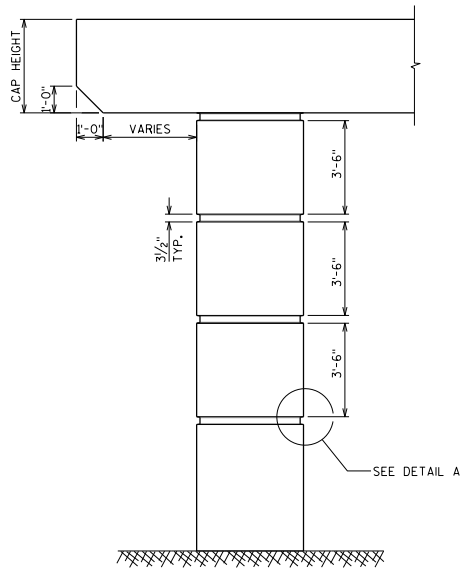

(P1) SINGLE RUSTICATION LINES

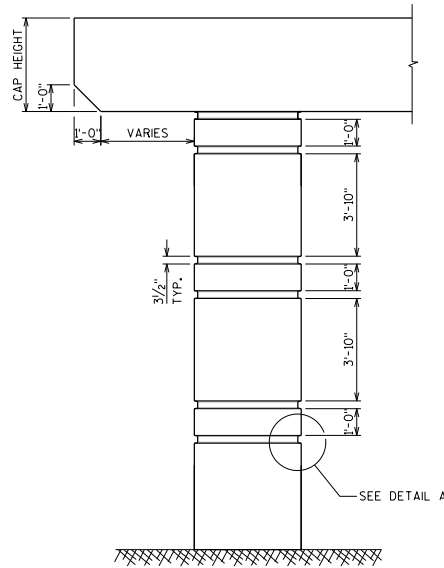

(P2) DOUBLE RUSTICATION LINES

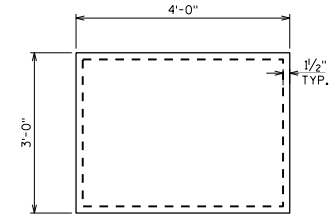

SECTION THRU COLUMN
SINGLE RUSTICATION LINES AND
DOUBLE RUSTICATION LINES

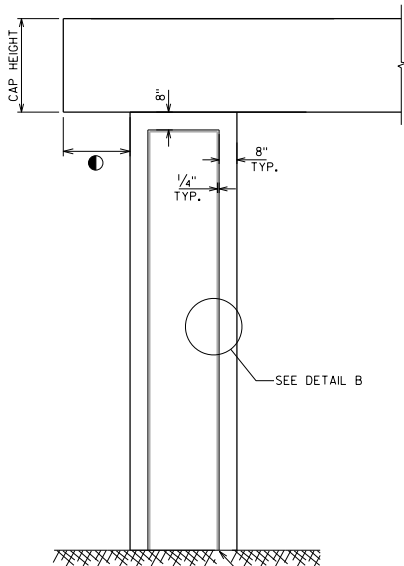

(P3) RECESSED PANEL

● DIM. = APPROXIMATELY 3/4 CAP HEIGHT

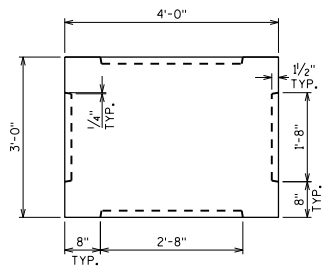

SECTION THRU COLUMN
RECESSED PANEL

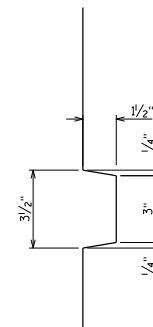

DETAIL A

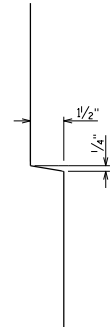

DETAIL B

MULTI-COLUMNED PIER
AESTHETIC DETAILS



BUREAU OF
STRUCTURES

APPROVED: *Laura Shadewald*

DATE:
7-15