

DESIGNER NOTES

LAP LENGTHS FOR HORIZONTAL BARS SHALL BE BASED ON A "CLASS C" TOP TENSION LAP SPLICE.

WING BARS AND DOWEL BARS SHALL BE EPOXY COATED.

PILING SPACING IN ABUTMENT BODY SHALL BE 8'-0" MAX. FOR ALL TYPES OF PILING. THE MAX. PILE SPACING FROM THE END OF THE ABUT. BODY TO THE FIRST PILE SHALL BE THE MINIMUM OF ONE-HALF PILE SPACE OR 2'-6".

TOTAL LENGTH OF [A] BARS SHALL BE ≥ TO WING LENGTH.

CONCRETE POURED UNDER WATER WILL BE ALLOWED AND SHALL BE DONE IN ACCORDANCE WITH SECTION 502.3.5.3 STANDARD SPECIFICATIONS.

THE SEMI-EXPANSION SEAT SHALL BE USED WHEN REQUIRED AS STATED IN CHAPTER 12, FIGURE 12.7-1 OF THE BRIDGE MANUAL OR WHENEVER A WING PILE IS REQUIRED.

THE FIXED SEAT CANNOT BE USED WHEN A WING PILE IS REQUIRED (SEE STD. 12.02 FOR CRITERIA).

WHEN THE BOTTOM OF GIRDER SLOPES MORE THAN 1%, SLOPE THE BEAM SEAT BASED ON ADDING THESE TWO VALUES:

- LONGITUDINAL GRADE OF GIRDER (PERCENT)
- CAMBER EFFECT = $4RC/L \times 100$ (PERCENT), WHERE:
RC = RESIDUAL CAMBER (INCHES)
L = GIRDER LENGTH (INCHES)

(SEE STANDARD 13.01 FOR SLOPED SEAT DETAILS)

ABUTMENT DETAILED WITHOUT STRUCTURAL APPROACH SLAB, SEE STD. 12.10 THRU 12.13 FOR STRUCTURAL APPROACH DETAILS.

USE THIS SHEET FOR BEAM SEAT DETAILS (WITH OR WITHOUT A STRUCTURAL APPROACH SLAB).

USE 3/4" THICK FILLER FOR SLAB STRUCTURES.

LEGEND

- ◆ #5 BARS (COATED) AT 1'-0" (2'-0" LONG). THESE BARS MAY BE PLACED AFTER CONCRETE IS POURED BUT BEFORE INITIAL SET HAS TAKEN PLACE.
- ◇ WHEN THIS DIMENSION > 4" THIS ADDITIONAL REINFORCEMENT SHALL BE ADDED. MAX. SPA. OF HORIZ. #4 BARS = 1'-0".
- USE 1'-3" FOR SLAB SPANS AND FOR GIRDER SPANS WITH NO PAVING NOTCH. USE 1'-6" FOR GIRDER SPANS WITH NO PAVING NOTCH, BUT WHERE 36"W, 45"W, 54"W, 70"W, 72"W OR 82"W GIRDERS ARE USED, AND SKEW > 25°. USE 1'-3" FOR SLAB SPANS WITH A PAVING NOTCH, BUT NO STRUCTURAL APPROACH SLAB. USE 1'-11" FOR GIRDER SPANS WITH A PAVING NOTCH, BUT NO STRUCTURAL APPROACH SLAB. USE 1'-7" FOR SLAB SPANS WITH A STRUCTURAL APPROACH SLAB. (STD. 12.10) USE 2'-3" FOR GIRDER SPANS WITH A STRUCTURAL APPROACH SLAB. (STD. 12.10)
- DIMENSION IS FROM BOTTOM OF ABUTMENT TO LOW BEAM SEAT OR LOW SIDE OF SLAB TYPE SUPERSTRUCTURE.
- ▽ 18" RUBBERIZED MEMBRANE WATERPROOFING. SEAL ALL HORIZONTAL AND VERTICAL JOINTS ON BACKFACE.
- ▲ KEYED CONST. JOINT FORMED BY BEVELED 2" x 6".
- * * * WINGWALL WIDTH SHALL BE 1'-6" WHEN TYPE "M" RAILING, VERTICAL FACE PARAPET "TX", OR SINGLE SLOPE PARAPET "5655" IS USED. "5655" SHOULD NOT BE USED ON A SIDEWALK. WINGWALL WIDTH SHALL BE 1'-4" WHEN PARAPET "A" ON A RAISED SIDEWALK IS USED. WINGWALL WIDTH SHALL BE 1'-9" WHEN TYPE "NY3" OR "NY4" RAILING IS USED. (USE 2'-0" WIDTH WHEN "NY4" IS USED ON A SIDEWALK).
- USE #5 BARS AT 6" SPA. IN OUTSIDE THIRDS OF BODY LENGTH WHEN THE WING LENGTH > 20'-0" AND WING HEIGHT > 10'-0".
- ☆ WHEN BODY SECTION IS > 50'-0" LONG PROVIDE VERTICAL CONSTRUCTION JOINT. RUN BAR STEEL THRU JOINT AND SEAL JOINT WITH 18" RUBBERIZED MEMBRANE WATERPROOFING. SEE STD. 12.09 FOR ALTERNATE CONSTRUCTION JOINT.
- SHOW ALL BARS FOR CLARITY.
- NO SLOPE FOR HEAVY RIPRAP. SEE STANDARD 12.08 FOR DETAILS.

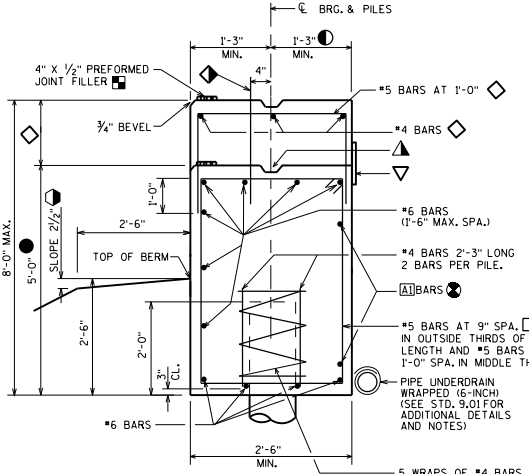

TYPE A1 WITH FIXED SEAT

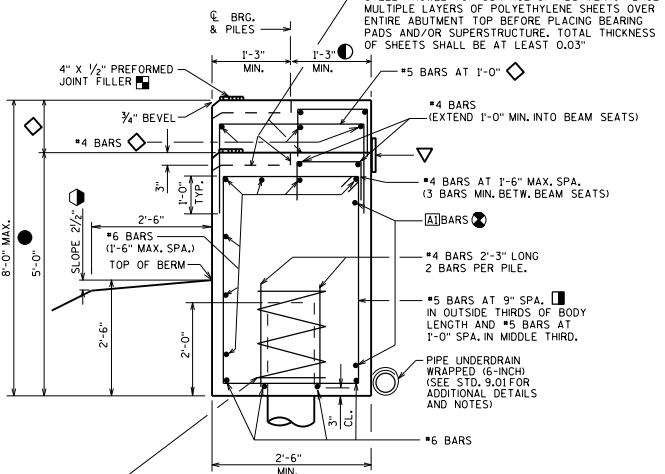

TYPE A1 WITH SEMI-EXPANSION SEAT

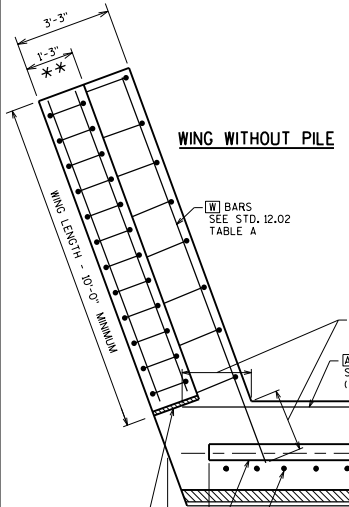

WING WITHOUT PILE

BAR SIZE	DISTANCE*
#5	1'-9"
#6	2'-1"
#7	2'-9"
#8	3'-8"
#9	4'-7"
#10	5'-10"

* OR EQUIVALENT STD. HOOK USE STRAIGHT BARS WHEN POSSIBLE

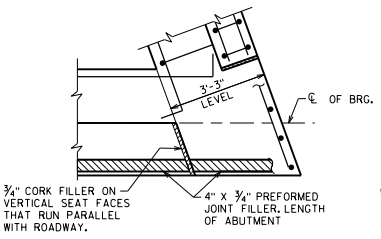

SLAB SPAN WITH SEMI-EXPANSION SEAT

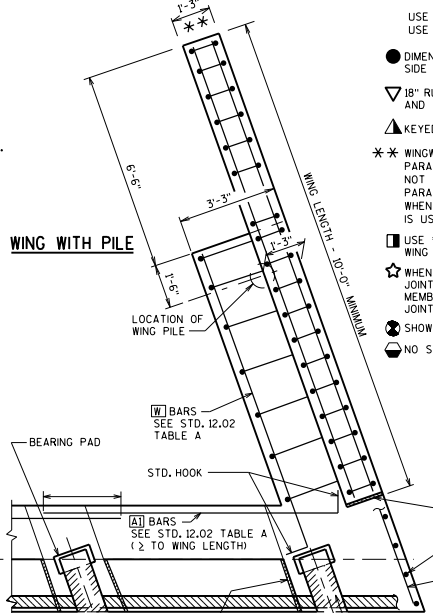

WING WITH PILE

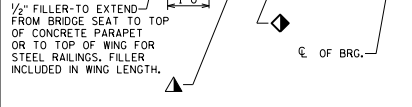

SLAB SPAN WITH FIXED SEAT

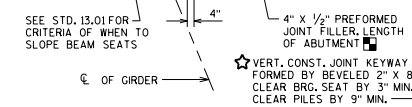

GIRDER SPAN WITH FIXED SEAT

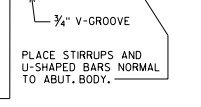

SLAB SPAN WITH SEMI-EXPANSION SEAT

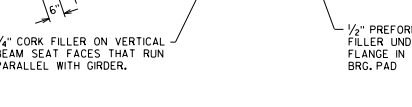

GIRDER SPAN WITH SEMI-EXPANSION SEAT

ABUTMENT TYPE A1 (INTEGRAL ABUTMENT)



APPROVED: *Laura Shadewald* DATE: 7-23