

SECTION THRU APPROACH SLAB

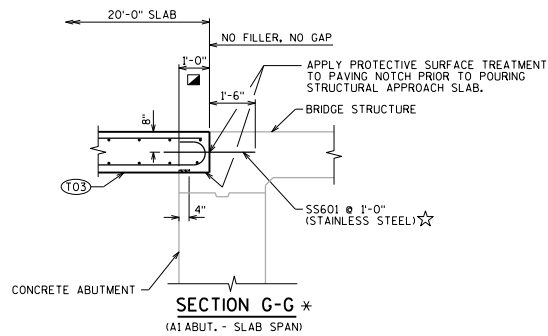

LEGEND

- (T02) STEEL TROWEL TOP SURFACE OF FOOTING AND PLACE MULTIPLE LAYERS (0.03" MIN. TOTAL THK.) OF POLYETHYLENE SHEETS OVER THE ENTIRE TOP OF FOOTING.
- (T03) PLACE MULTIPLE LAYERS (0.03" MIN. TOTAL THK.) OF POLYETHYLENE SHEETS OVER THE ENTIRE TOP OF SUBGRADE BENEATH SLAB.
- MEASURED NORMAL TO ABUTMENT
- FOLLOW FDM 14-10-25 REQUIREMENTS FOR ROADWAY APPROACH PAVEMENT.
- * SECTION REPRESENTATIVE OF SIMILAR LOCATION AS SHOWN ON STANDARD 12.10 FOR DIFFERENT APPLICATION.
- ☆ THE BID ITEM FOR SS901 AND SS601 BARS SHALL BE STANDARD SPECIAL PROVISION "BAR STEEL REINFORCEMENT HS STAINLESS STRUCTURES".
- ▽ R501 BARS TO BE TIED TO STRUCTURAL APPROACH SLAB STEEL AND ABUT. STEEL BEFORE STRUCTURAL APPROACH SLAB IS POURED.

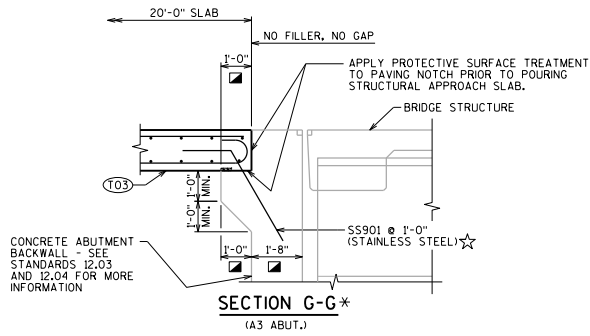
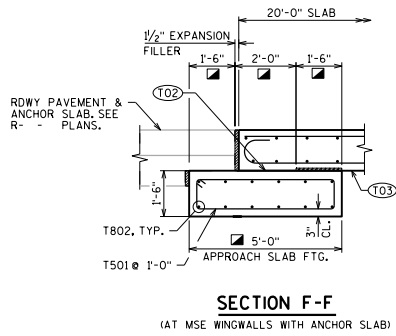
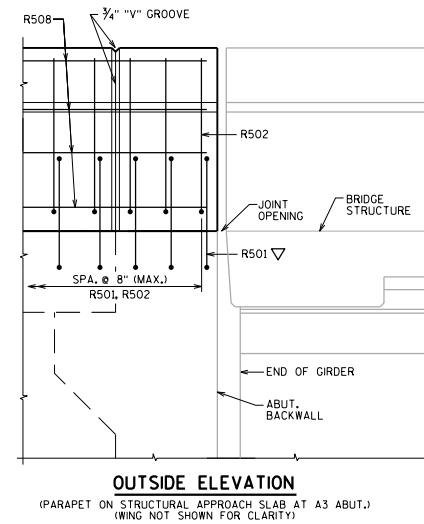
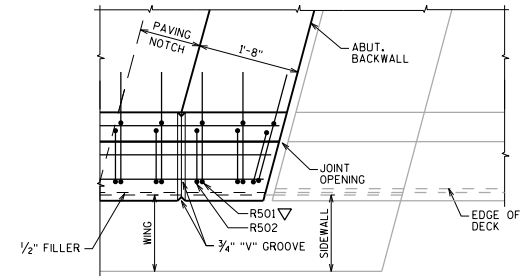

DESIGNER NOTES

SEE CHAPTER 30 FOR PARAPETS ON STRUCTURAL APPROACH SLAB DETAILS.
SECTIONS A-A THRU G-G ARE FROM STANDARD 12.10

STRUCTURAL APPROACH SLAB DETAILS 2	
	BUREAU OF STRUCTURES
APPROVED: <i>Laura Shadewald</i>	DATE: 7-19