

**NOTES**

- TYPE 1 [ AT PIER ... CONCRETE POURED UNDERWATER WILL BE ALLOWED AND SHALL BE DONE IN ACCORDANCE WITH STANDARD SPEC 502.3.5.3. CONCRETE POURED UNDERWATER SHALL NOT EXCEED 10.0 FEET IN DEPTH, UNLESS APPROVED OTHERWISE.
- TYPE 2 [ AT PIER ... COFFERDAM REQUIRED. CONCRETE POURED UNDERWATER WILL BE ALLOWED AND SHALL BE DONE IN ACCORDANCE WITH STANDARD SPEC 502.3.5.3. CONCRETE POURED UNDERWATER SHALL NOT EXCEED 10.0 FEET IN DEPTH, UNLESS APPROVED OTHERWISE.
- TYPE 3 [ AT PIER ... COFFERDAM AND COFFERDAM DEWATERING REQUIRED. COFFERDAM SHALL BE DEWATERED PRIOR TO PLACING PIER CONCRETE.

**DESIGNER NOTES**

SEE BRIDGE MANUAL SECTION 13.2.3 AND STANDARD 13.09 FOR GUIDANCE ON PIER TYPES, DETAILS, AND APPLICABLE BID ITEMS.

SEE BRIDGE MANUAL SECTION 13.11.5 FOR GUIDANCE ON COFFERDAMS.

CONSTRUCTION JOINTS ARE NOT REQUIRED, REGARDLESS OF LENGTH OF PILE ENCASED PIER.

SEE STANDARD 13.01 FOR ADDITIONAL, APPLICABLE DESIGNER NOTES

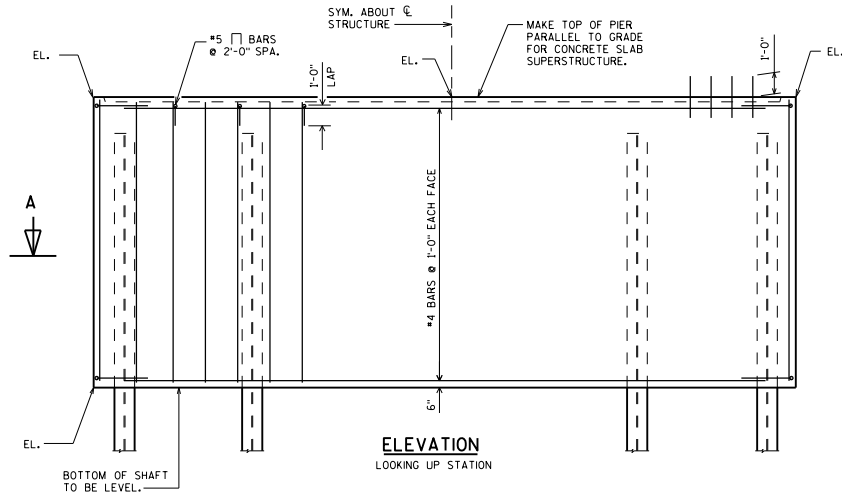

**ELEVATION**  
LOOKING UP STATION

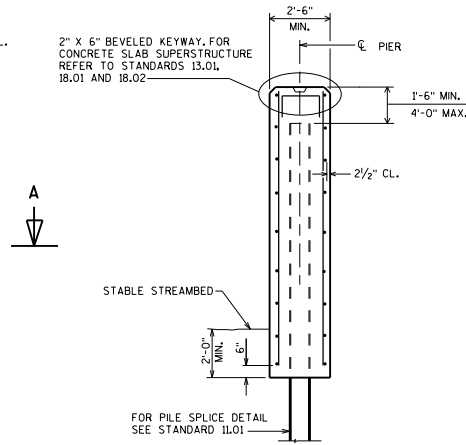

**END VIEW**

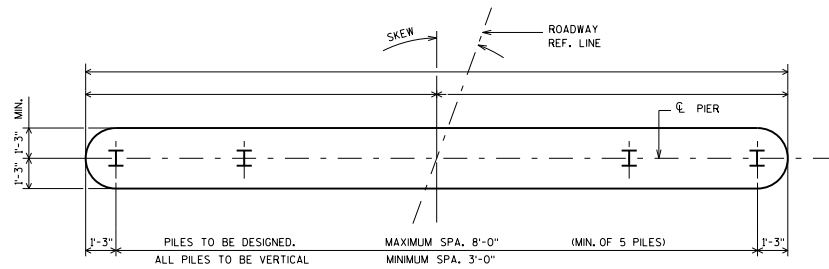

**PLAN**

STEEL PILING SHOWN, CAST IN PLACE CONC. PILING LAYOUT SIMILAR.

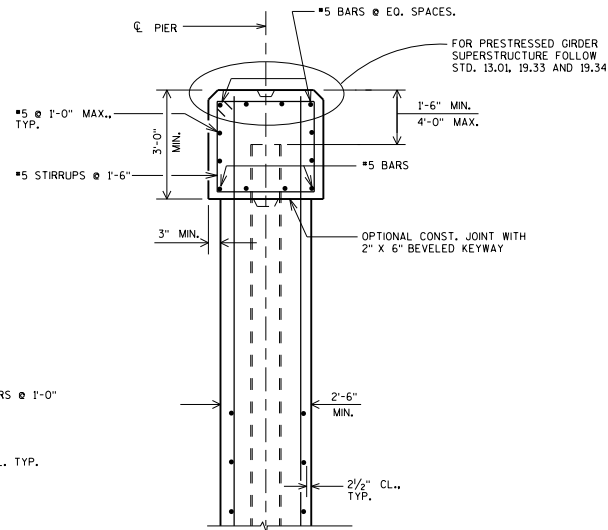

**CAP TYPE DETAIL**

USE WHEN ECONOMICAL FOR GIRDERS ON LARGE SKEWS

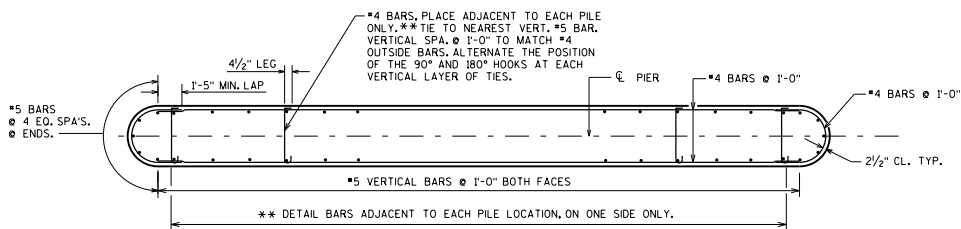

**SECTION A-A**

**PILE ENCASED PIER**



APPROVED: *Laura Shadewald* DATE: 7-19