

**PART TRANSVERSE SECTION AT ABUTMENT
TYPE A1 DIAPHRAGM WITH A RAISED SIDEWALK**

(HORIZ. BARS SHOWN ARE THE FF BARS.
DECK REINFORCEMENT NOT SHOWN FOR CLARITY.)

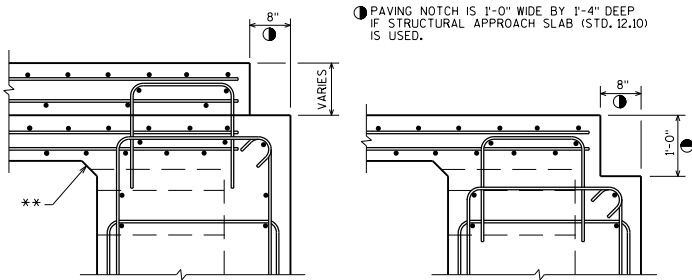

SECTION A-A

** 3" X 3" BEVEL ENDS AT EDGE OF BRIDGE DECK

SECTION B-B

- SEE STANDARDS 19.33, 19.34, 19.35 FOR REINFORCEMENT DETAILS
- DETAILS SHOWN ARE FOR GIRDER STRUCTURES. SIMILAR REINFORCEMENT FOR SLAB STRUCTURES SHALL BE USED WITH A REMINDER THAT THE TRANSVERSE AND LONGITUDINAL REINFORCEMENT LAYERS ARE REVERSED.

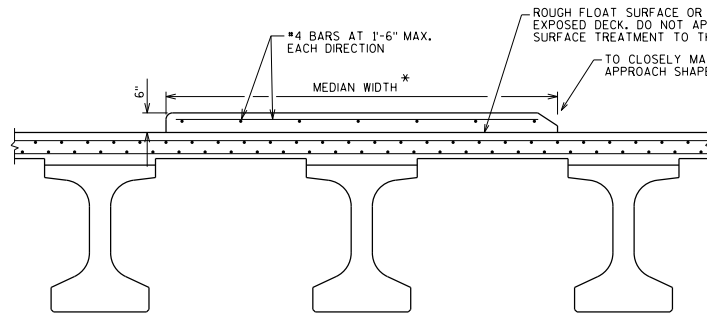

CROSS SECTION THRU UNANCHORED MEDIAN

* (ANCHORAGE TO DECK NOT REQUIRED FOR WIDTHS > 3'-0", EXCEPT ALL MEDIAN SECTIONS ON TOP OF PAVING BLOCK MUST BE ANCHORED)

NOTE: CLEAN ALL LOOSE MATERIAL ON THE DECK AT THE MEDIAN LOCATION PRIOR TO MEDIAN PLACEMENT USING HIGH PRESSURE WATER OR AIR, ENSURING ALL FREE-STANDING WATER IS REMOVED PRIOR TO MEDIAN PLACEMENT. NEAT CEMENT IS REQUIRED AS PER 509.3.9.2 OF THE STANDARD SPECIFICATIONS UNLESS THE MEDIAN IS POURED WITHIN 45 DAYS OF COMPLETING THE DECK POUR.

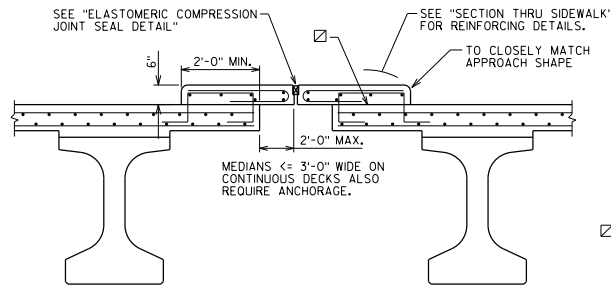

CROSS SECTION THRU MEDIAN WITH A JOINT

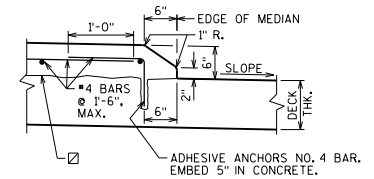

ANCHORED MEDIAN CURB DETAIL

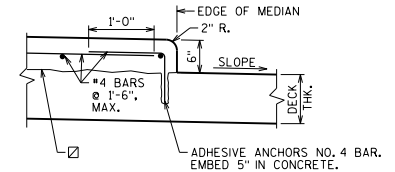

ANCHORED MEDIAN CURB DETAIL

☑ CONST. JOINT-STRIKE OFF AS SHOWN AND LEAVE ROUGH, FOR DECK POUR, MATCH BRIDGE X-SLOPE.

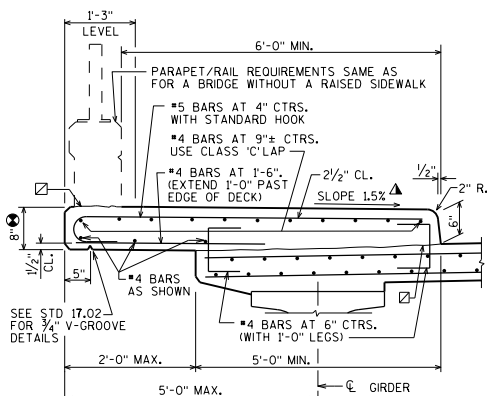

SECTION THRU SIDEWALK

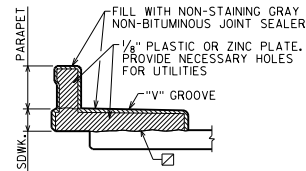

DEFLECTION JOINT DETAIL

SHOW DEFLECTION JOINT IN PARAPET OR SIDEWALK USING THE FOLLOWING CRITERIA:

1. GIRDER STRUCTURES AND SLAB STRUCTURES WITH A RAISED SIDEWALK SHOULD HAVE A DEFLECTION JOINT IN THE SIDEWALK AND PARAPET OVER THE PIER. FOR SKEWS GREATER THAN 20°, DETAIL THE JOINT NORMAL TO THE SIDEWALK AND PARAPET WITH THE JOINT APPROX. CENTERED OVER THE PIER.

IF THERE IS A LIGHT STANDARD AT THE PIER, PLACE A DEFLECTION JOINT APPROX. 4'-0" EACH SIDE OF PIER, WITH NONE DIRECTLY OVER THE PIER.

2. GIRDER STRUCTURES AND SLAB STRUCTURES WITHOUT SIDEWALKS SHOULD HAVE NO DEFLECTION JOINTS IN THE PARAPETS.

NOTES

WHEN PARAPETS ARE POURED CONTINUOUSLY FROM END TO END, THEY SHALL BE SEPARATED AT THE DEFLECTION JOINTS BY A PIECE OF 1/8" ZINC OR PLASTIC PLATE CUT AS SHOWN IN THE "DEFLECTION JOINT DETAIL". IF CONSTRUCTION JOINTS IN PARAPETS ARE USED AT THE DEFLECTION JOINTS, ONE SIDE OF JOINT SHALL BE COATED WITH AN APPROVED LIQUID BOND BREAKER AND PLATE SEPARATORS MAY BE OMITTED.

☑ CONST. JOINT-STRIKE OFF AS SHOWN AND LEAVE ROUGH, FOR DECK POUR, MATCH BRIDGE X-SLOPE.

● 8" MIN. SIDEWALK THICKNESS ALSO REQ'D AT EDGE OF DECK/SLAB.

▲ ±0.5% CONSTRUCTION TOLERANCE IN SIDEWALK CROSS SLOPE. THE SIDEWALK CROSS SLOPE SHALL NOT EXCEED 2% WITHOUT PRIOR APPROVAL FROM THE ENGINEER.

DESIGNER NOTES

FOR EXTREME SIDEWALK WIDTHS AND/OR SUPERELEVATIONS THE DECK MAY BE LEVEL BENEATH THE SIDEWALK (MAINTAIN CONSTANT DECK THICKNESS) TO REDUCE EXCESSIVE SIDEWALK THICKNESS.

FOR DEAD LOAD PURPOSES, THE SUPERSTRUCTURE DESIGN SHALL ACCOUNT FOR A MAXIMUM 2% SIDEWALK CROSS SLOPE.

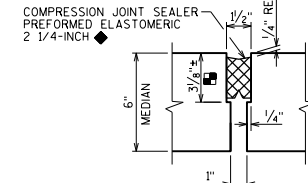

ELASTOMERIC COMPRESSION SEAL DETAIL

■ VARIES BASED ON JOINT MANUFACTURER
◆ MANUFACTURER SHALL LABEL TOP OF SEAL

MEDIAN AND RAISED SIDEWALK DETAILS



APPROVED: *Laura Shadewald*

DATE: 1-22

SEE STD. 24.11 FOR DECK JOINT DETAIL FOR LONGITUDINAL AND TRANSVERSE JOINTS.