

PRESTRESSED GIRDER WITH SEMI-EXPANSION SEAT

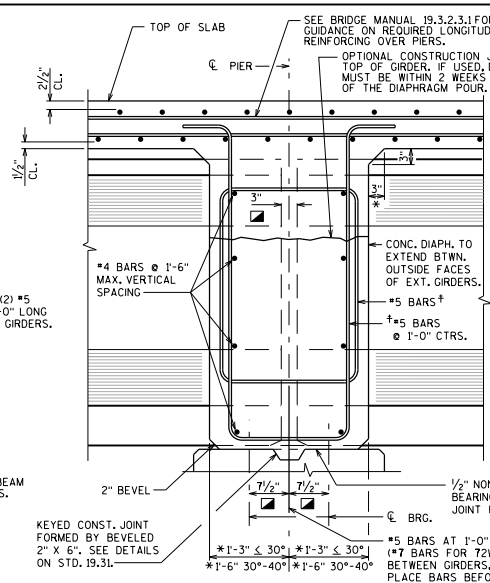

DIAPHRAGM AT 1/2" ELASTOMERIC BEARING

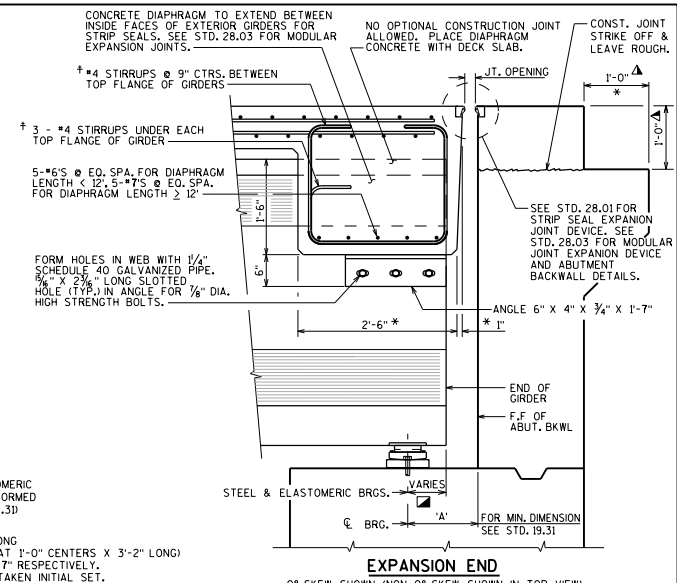

LEGEND

- ▣ DIMENSION IS TAKEN PARALLEL TO ϕ GIRDER.
- * DIMENSION IS TAKEN NORMAL TO ϕ SUBSTRUCTURE UNITS.
- △ PAVING NOTCH IS 1'-0" WIDE BY 1'-4" DEEP IF STRUCTURAL APPROACH SLAB (STD. 12.10) IS USED, SHOW NO. 9 STAINLESS STEEL BAR (STD. 12.12) FOR STRUCTURAL APPROACH SLAB ON THE SECTION THRU ABUT. OR ABUT. DIAPH.
- † BARS PLACED PARALLEL TO GIRDERS. SPACING PERPENDICULAR TO ϕ GIRDERS.

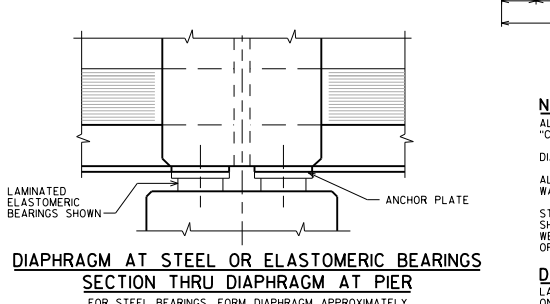
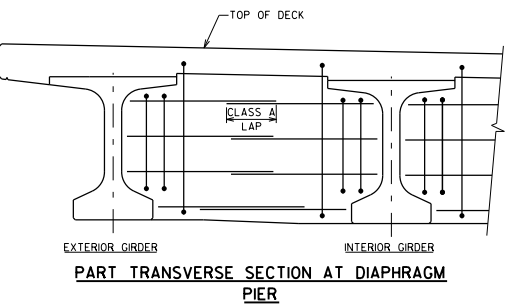
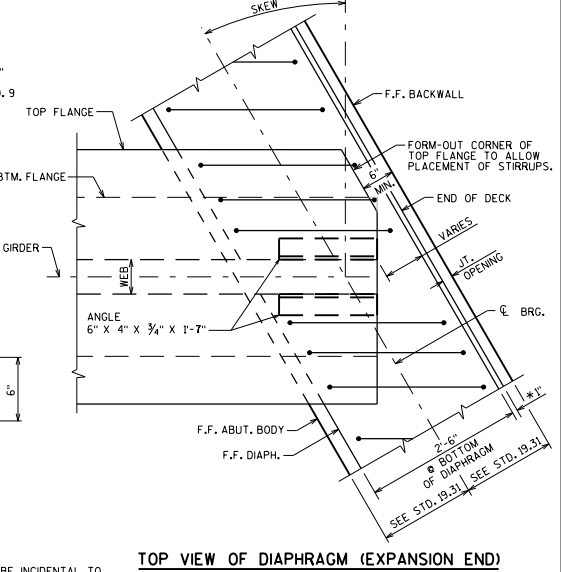
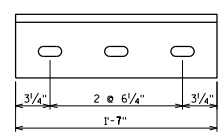
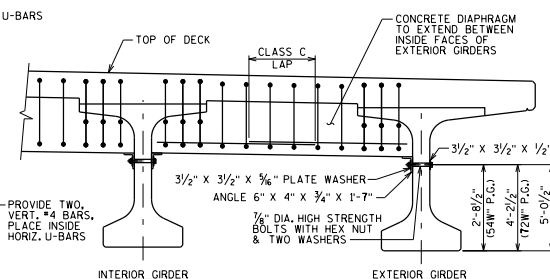
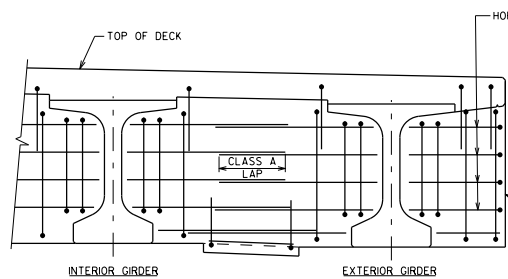

NOTES

- ALL DIAPHRAGM SUPPORT HARDWARE SHALL BE INCIDENTAL TO "CONCRETE MASONRY BRIDGES".
- DIAPHRAGM SUPPORT ANGLES SHALL BE ASTM A709 GRADE 36.
- ALL DIAPHRAGM SUPPORT HARDWARE INCLUDING BOLTS, NUTS AND WASHERS SHALL BE GALVANIZED AFTER FABRICATION.
- STEEL DIAPHRAGM SUPPORT ANGLE TO CONCRETE WEB CONNECTION SHALL BE SNUG-TIGHT PLUS 1/4 TURN, HIGH STRENGTH BOLTS FOR WEB CONNECTION SHALL MEET THE REQUIREMENTS FOR ASTM A325 OR ASTM A449.

DESIGNER NOTES

- LAP LENGTHS FOR DIAPHRAGM REINFORCEMENT SHALL BE BASED ON A CLASS "C" TENSION LAP SPLICE, UNLESS OTHERWISE NOTED.

PRESTRESSED 54" & 72" & 82" GIRDER SLAB & SUPERSTRUCTURE DETAILS

BUREAU OF STRUCTURES

APPROVED: *Laura Shadewald*

DATE: 1-19