

3'-0" SECTIONS

REBAR DIMENSION

SECT. DEPTH	SECT. NO.	"A"	"B"	"C"
1'-0"	1	7 1/2"	7 1/2"	6"
1'-5"	2	9"	1'-1"	10"
1'-9"	3	1'-3"	1'-5"	1'-2"
2'-3"	4	1'-3"	1'-11"	1'-8"
2'-9"	5	1'-3"	2'-5"	2'-2"
3'-6"	6	1'-3"	3'-2"	2'-11"

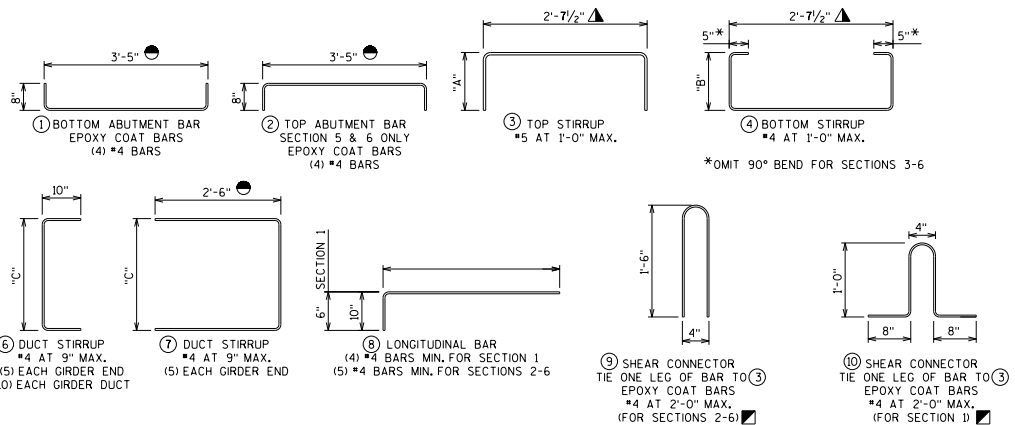

NOTES

THE CONCRETE MIX FOR THE PRESTRESSED BOX GIRDERS SHALL CONFORM TO SECTION 503.2.2 OF THE STANDARD SPECIFICATIONS.

AN APPROVED CONCRETE SEALER SHALL BE APPLIED TO THE BOTTOM OF THE GIRDERS AND THE EXTERIOR FACE OF EXTERIOR GIRDERS. DO NOT APPLY CONCRETE SEALER OR EPOXY TO THE SHEAR KEY OR THE TOP OF GIRDERS.

STRANDS SHALL BE FLUSH WITH END OF GIRDER, FOR CONCRETE ABUTMENTS END OF STRANDS SHALL BE COATED WITH NON-BITUMINOUS JOINT SEALER. FOR GRS ABUTMENTS, COAT THE GIRDER ENDS, EXPOSED STRAND ENDS, AND ALL NON-BONDING SURFACES WITHIN 2 FEET OF THE GIRDER ENDS WITH A NON-PIGMENTED EPOXY CONFORMING TO AASHTO M-235 TYPE III, GRADE 2, CLASS B OR C. THE EPOXY SHALL BE APPLIED AT LEAST 3 DAYS AFTER MOIST CURING HAS CEASED AND PRIOR TO THE APPLICATION OF THE SEALER.

VOIDS SHALL BE VENTED AND DRAINED BY CASTING (2)-1" DIA. TUBES AT EACH END OF VOID SEGMENT. LOCATE TUBES AT BOTTOM EDGES OF THE CORNER FILLETS, AVOID STRAND LOCATIONS.

FOUR WAY SLING MUST BE USED TO ENGAGE ALL 4 LIFTING DEVICES ON BOTH ENDS OF UNITS.

POST-TENSIONING OF THE TRANSVERSE TENDONS SHALL NOT BEGIN UNTIL THE GROUT BETWEEN THE PRECAST BOX GIRDERS HAS BEEN ALLOWED TO CURE FOR 48 HOURS AND GROUT HAS REACHED A COMPRESSIVE STRENGTH OF 3,000 PSI.

SEAL WASHER SHALL BE SPONGE NEOPRENE GASKET 3/4" MIN. THICK. STRESS POCKETS SHALL BE FILLED WITH CHLORIDE FREE NON-SHRINK GROUT AFTER POST-TENSIONING.

TRANSITION BETWEEN CHANGING SLOPES OF POST-TENSIONING DUCTS SHALL BE PROVIDED BY EITHER A CIRCULAR OR PARABOLIC CURVE WITH A MINIMUM LENGTH OF 3'-0".

DESIGNER NOTES

USE OF PRESTRESSED BOX GIRDERS IS SUBJECT TO PRIOR-APPROVAL BY THE BUREAU OF STRUCTURES. SEE 19.3.2.3.2 IN THE BRIDGE MANUAL FOR ADDITIONAL GUIDANCE.

THE MAXIMUM RECOMMENDED SKEW ANGLE OF THE STRUCTURE SHALL BE 30°.

BEAM SEATS SHALL BE SLOPED ALONG THE SUBSTRUCTURE UNITS TO ACCOUNT FOR THE CROSS SLOPE OR SUPERELEVATION ON THE DECK.

SLOPE BEAM SEATS PARALLEL TO GRADE LINE IF GRADE AT BRG. > 1%, PLACE ELEVATIONS ON PLANS TO MEET THESE REQUIREMENTS.

STRANDS TO BE DESIGNED, MAXIMUM NUMBER OF STRANDS AND STRAND ARRANGEMENTS ARE SHOWN, STRANDS NOT TO BE DRAPED.

MULTI-SPAN STRUCTURES REQUIRE ANCHOR DOWELS AT THE PIERS, WHICH MAY REDUCE THE MAXIMUM NUMBER OF STRANDS AVAILABLE BY 2. (CURRENTLY NOT USED)

CONTACT THE BUREAU OF STRUCTURES FOR THE MOST CURRENT PRESTRESSED BOX GIRDER SPECIAL PROVISION.

SEE STANDARD 19.51 FOR SHEAR KEY RECESS DETAIL.

MATERIAL PROPERTIES

- CONCRETE MASONRY BRIDGES $f_c = 4,000$ PSI
- BAR STEEL REINFORCEMENT, GRADE 60 $f_y = 60,000$ PSI
- PRESTRESSED BOX GIRDERS, CONCRETE MASONRY $f_c = 5,000$ PSI
- STRANDS - 0.5" OR 0.6" DIA. ULTIMATE TENSILE STRENGTH $f_t = 270,000$ PSI

PRE-TENSION

- $f_t = 270,000$ P.S.I
- $f_s = 0.75 \times 270,000 = 202,500$ P.S.I for low relaxation strands
- PI PER 0.5" DIA. STRAND = $0.1531 \times 202,500 = 31.00$ KIPS
- PI PER 0.6" DIA. STRAND = $0.217 \times 202,500 = 43.94$ KIPS

LEGEND

- DIMENSION GIVEN FOR A POST-TENSIONING DUCT 1'-10" FROM END OF PRESTRESSED BOX GIRDER.
- ▲ DIMENSION GIVEN FOR STIRRUPS PERPENDICULAR TO THE PRESTRESSED BOX GIRDER LENGTH. ADJUST THE DIMENSION FOR STIRRUPS AT SKEWED PRESTRESSED BOX GIRDER ENDS.
- ⊗ SHOW SPACING FOR THESE STRANDS ONLY IF REQUIRED BY DESIGN.
- SUBSTITUTE (1) BAR ON EXTERIOR EDGE OF EXTERIOR GIRDERS. SEE STANDARD 19.56.

3'-0" PRESTRESSED BOX GIRDER SECTIONS

BUREAU OF STRUCTURES

APPROVED: *Laura Shadewald* DATE: 7-18