

TYPICAL SECTION THRU JOINT AT STEEL GIRDER

NORMAL TO \bar{C} SUBSTRUCTURE

* POUR CONC. ABOVE THIS JOINT AFTER SUPERSTRUCTURE IS IN PLACE. STRIKE OFF AND LEAVE ROUGH.

■ PAVING NOTCH IS 1'-0" WIDE BY 1'-4" DEEP IF STRUCTURAL APPROACH SLAB (STD. 12.12) IS USED.

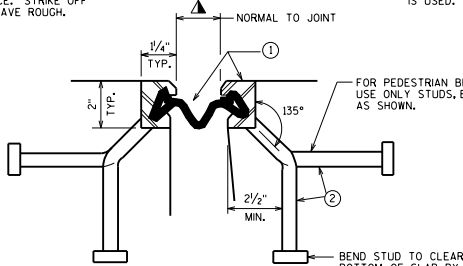

SECTION THRU JOINT

EXTERIOR GIRDER TO EDGE OF DECK, AND AT PARAPETS, MEDIANS AND SIDEWALKS

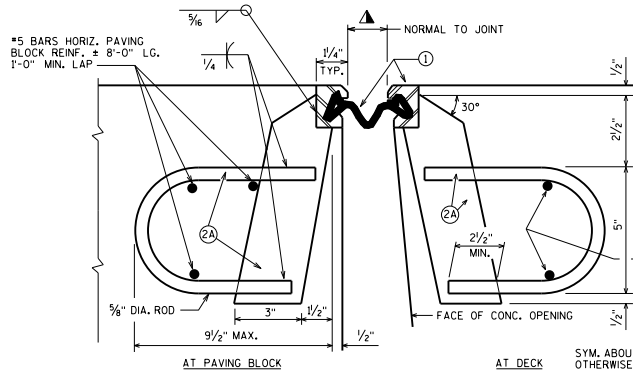

SECTION THRU JOINT

ROADWAY TRAFFIC AREA BETWEEN EXTERIOR GIRDERS.

SYM. ABOUT \bar{C} JOINT UNLESS OTHERWISE SHOWN OR NOTED

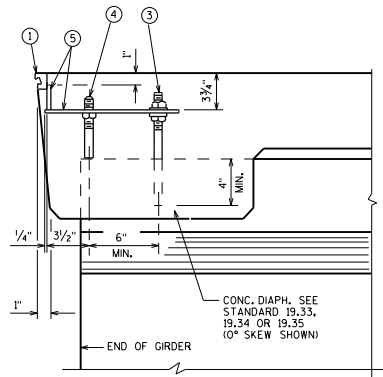

PART SECTION THRU JOINT AT PRESTRESSED GIRDERS

NORMAL TO \bar{C} SUBSTRUCTURE

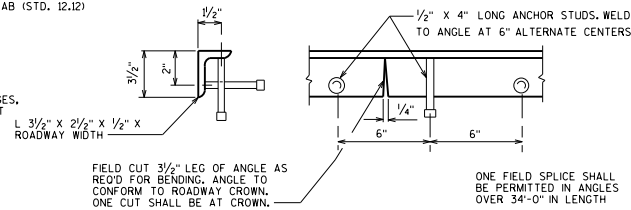

PROTECTION ANGLE ARMOR

SANDBLAST PROTECTION ANGLE AFTER FABRICATION PER NOTES. AFTER BLAST CLEANING, THE PROTECTION ANGLE SHALL BE HOT DIPPED GALVANIZED.

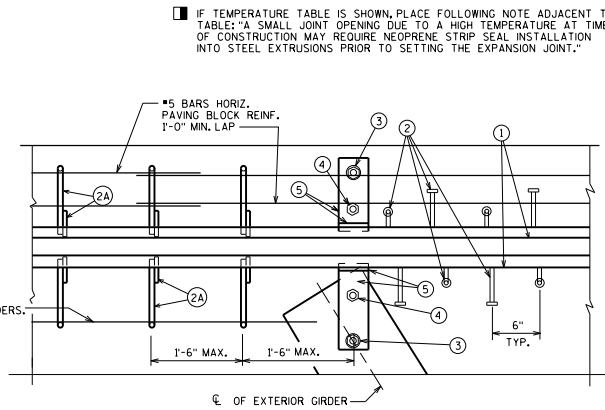

PART PLAN

LEGEND

- ▲ ① NEOPRENE STRIP SEAL (1-INCH) AND STEEL EXTRUSIONS. SET JOINT OPENING AT 1 1/2" WHEN EXPANSION LENGTH < 230'-0". WHEN EXPANSION LENGTH > 230'-0", PREPARE A TEMPERATURE TABLE SHOWING JOINT OPENINGS FROM 5°F TO 85°F IN 10°F INCREMENTS. ACCOUNT FOR PRESTRESSED GIRDER SHRINKAGE DUE TO CREEP WHEN DETERMINING THIS TABLE. JOINT OPENINGS GIVEN NORMAL TO JOINT. ■
- ② STUDS 3/4" DIA. X 6 3/4" LONG AT 6" ALTERNATE CENTERS. WELD TO EXTRUSIONS AND BEND AS SHOWN AFTER WELDING.
- ②A 1/2" THICK ANCHOR PLATE WITH 3/4" DIA. ROD (OR ALTERNATE STRIP SEAL ANCHOR). WELD ROD TO ANCHOR PLATE, WELD ANCHOR PLATE TO NO. 1 AT 1'-6" CENTERS BETWEEN GIRDERS.
- ③ 3/4" DIA. THREADED ROD WITH 2 NUTS AND PLATE WASHERS. FOR PRESTRESSED GIRDERS, GROUT THREADED ROD INTO FIELD DRILLED HOLES ON \bar{C} OF GIRDER. FOR STEEL GIRDERS, WELD THREADED ROD TO TOP FLANGE OR ATTACH BY BOLTING THRU FLANGE. ON ABUTMENT SIDE, GROUT THREADED ROD INTO FIELD DRILLED HOLES IN ABUTMENT BACKWALL AS SHOWN.
- ④ 3/4" DIA. THREADED ROD WITH NUT. TACK WELD NUT TO NO. 5.
- ⑤ FABRICATE SUPPORT FROM 3" X 1/2" BAR AS SHOWN OR EQUIVALENT. ONE PER GIRDER PER SIDE. SHOP OR FIELD WELD TO NO. 1. IF FIELD WELDED, COVER WELDED AREAS WITH EPOXY-COATING MATERIAL. PROVIDE 1/2" DIA. HOLE FOR NO. 3 AND 1" DIA. HOLE FOR NO. 4.
- ⑥ GALVANIZED PLATE 3/4" X 10" X 12'-2" LONG FOR SKEWS TO 45° AND 3'-0" LONG FOR SKEWS > 45° WITH HOLES FOR NO. 7. FOR SINGLE SLOPE PARAPET. FOR SLOPED FACE PARAPET, SEE STANDARD 28.07.
- ⑦ 3/4" DIA. X 1 1/2" STAINLESS STEEL SOCKET FLAT HEAD SCREWS WITH ANTI-SEIZE LUBRICANT. PLACE IN COUNTERSUNK HOLE. RECESS 1/16" BELOW PLATE SURFACE.
- ⑧ 3/4" DIA. X 4" GALVANIZED HEX HEAD BOLT, BEND 45°.
- ⑨ 3/4" DIA. X 2 1/4" GALVANIZED THREADED COUPLING.
- ⑩ SIDEWALK COVER PLATE 3/2" X 12'-0" WIDE FOR SKEWS TO 45° AND 3'-0" WIDE FOR SKEWS > 45° X LIMITS SHOWN. BEND DOWN FACE OF SIDEWALK WITH HOLES FOR NO. 7. GALVANIZE PLATE AFTER SLIP-RESISTANT SURFACE IS APPLIED.
- ⑪ 1" X 5" SLOTTED COUNTERSUNK HOLE FOR NO. 7. PLACE SLOT PARALLEL TO DIRECTION OF MOVEMENT.

NOTES

ONE FIELD SPLICE PERMITTED IN STEEL EXTRUSIONS, UNLESS MORE ARE REQUIRED FOR STAGED CONSTRUCTION HANDLING OR GALVANIZING REQUIREMENTS. IF USED, ANCHOR PLATES SHALL BE PROVIDED 3" FROM EACH SIDE OF THE FIELD SPLICE. DETAILS SHALL BE SUBMITTED FOR APPROVAL. NO SPLICING PERMITTED IN NEOPRENE STRIP SEAL.

AFTER FABRICATION, BUT BEFORE SHIPMENT, STRAIGHTEN STEEL EXTRUSIONS SUCH THAT THEY SHALL BE FREE FROM WARP, TWIST AND SWEEP.

FABRICATOR SHALL PROVIDE MEANS OF KEEPING GALVANIZED EXTRUSIONS CLEAN AND SMOOTH DURING SHIPMENT AND PRIOR TO APPLYING LUBRICANT ADHESIVE FOR NEOPRENE GLAND INSTALLATION.

SANDBLAST PLATES, SUPPORTS AND EXTRUSIONS AFTER FABRICATION IN ACCORDANCE WITH SSPC SP. #6 "COMMERCIAL BLAST CLEANING". AFTER BLAST CLEANING, THE PLATES, SUPPORTS AND EXTRUSIONS SHALL BE HOT DIPPED GALVANIZED. SLIP-RESISTANT SURFACE IS APPLIED TO SIDEWALK COVER PLATES BY THE MANUFACTURER AND THEN HOT DIPPED GALVANIZED TO THEIR RECOMMENDATIONS TO MAINTAIN THE INTEGRITY OF THIS SURFACE.

ANCHOR SYSTEM NO. 8 AND NO. 9 SHALL CONFORM TO ASTM A307 AND SHALL BE GALVANIZED IN ACCORDANCE WITH ASTM A153 CLASS C AND D.

ALL MATERIAL IN THE EXPANSION JOINT ASSEMBLY, INCLUDING ANCHOR STUDS AND HARDWARE SHALL BE PAID AT THE UNIT PRICE BID FOR "EXPANSION DEVICE", L.F.

■ IF TEMPERATURE TABLE IS SHOWN, PLACE FOLLOWING NOTE ADJACENT TO TABLE: "A SMALL JOINT OPENING DUE TO A HIGH TEMPERATURE AT TIME OF CONSTRUCTION MAY REQUIRE NEOPRENE STRIP SEAL INSTALLATION INTO STEEL EXTRUSIONS PRIOR TO SETTING THE EXPANSION JOINT."

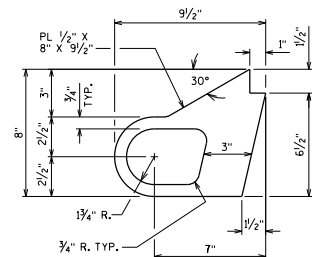

ALTERNATE STRIP SEAL ANCHOR

STRIP SEAL EXPANSION JOINT DETAILS



APPROVED: *Laura Shadewald* DATE: 1-23