

PLAN

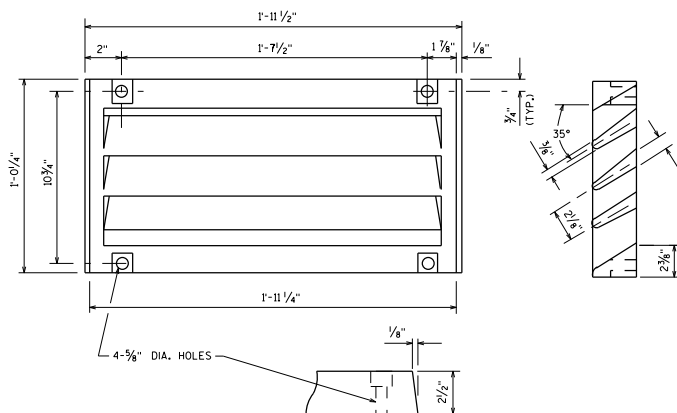

GRATE CASTING DETAIL  
ATTACH GRATE TO FRAME FOR SHIPMENT

TRANS. AND LONGIT. SLAB BAR REINF. TO BE CUT A MAX. OF 1" CL. FROM DRAIN FRAME. DISPLACE BARS WHERE POSSIBLE.

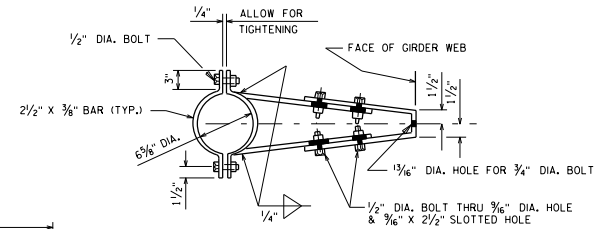

BRACKET DETAIL

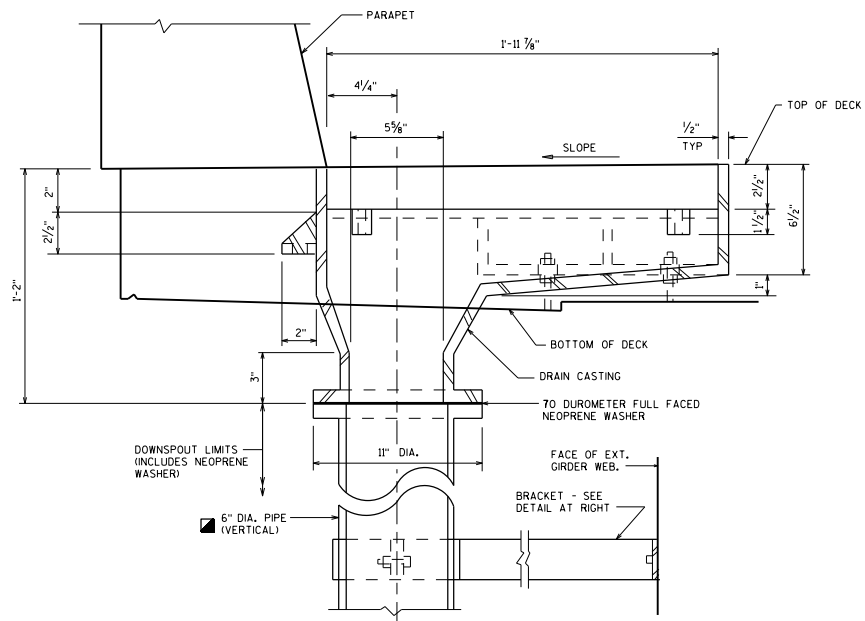

SECTION A1

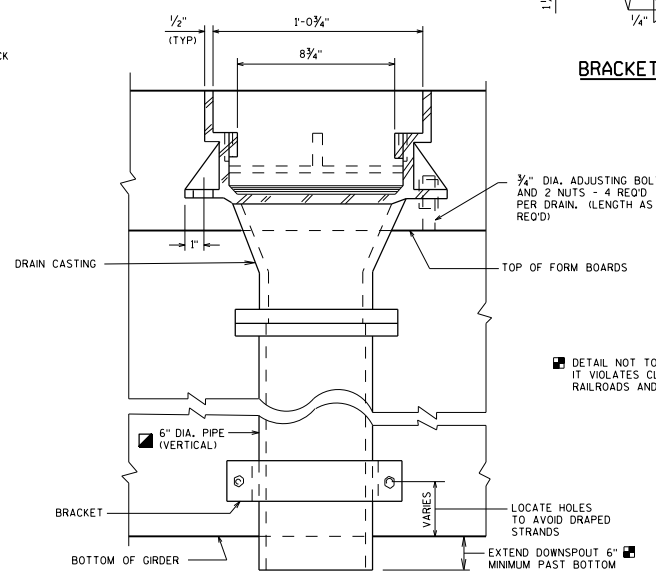

SECTION A2

NOTES

- ALL MATERIAL FOR TYPE "GC" CASTING, EXCLUDING GRATE HOLD DOWN SCREWS, SHALL BE GRAY IRON CONFORMING TO ASTM A48, CLASS 30. (APPROXIMATE WEIGHT = 225#)
- MATERIAL FOR BRACKETS SHALL CONFORM TO ASTM A36.
- ALL MATERIAL FOR FLOOR DRAINS TO BE INCLUDED IN THE BID ITEM "FLOOR DRAINS TYPE GC".
- ALL MATERIAL FOR DOWNSPOUTS, DOWNSPOUT CONNECTIONS, AND BRACKETS TO BE INCLUDED IN THE BID ITEM "DOWNSPOUT 6-INCH".
- ALTERNATE BRACKETS ARE NOT ALLOWED.
- FLANGED 6" DIA. DOWNSPOUTS SHALL BE REINFORCED THERMOSETTING RESIN PIPE (RTRP) OR GALVANIZED STANDARD PIPE CONFORMING TO ASTM A53.

DESIGNER NOTE

ON THE PRESTRESSED GIRDER SHEET, SHOW LOCATION OF HOLES FOR BRACKET ANCHORAGE FROM TOP/BOTTOM AND END OF GIRDER.

<b>FLOOR DRAIN TYPE 'GC'</b>	
	<b>BUREAU OF STRUCTURES</b>
APPROVED: <i>Laura Shadewald</i>	DATE: 1-20