

PLAN

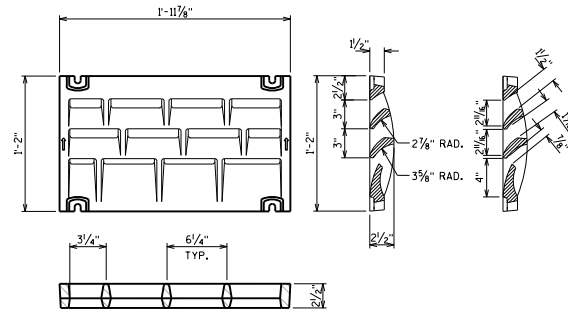

GRATE CASTING DETAILS

ATTACH GRATES TO FRAME FOR SHIPMENT

NOTES

ALL MATERIAL FOR TYPE "WF" CASTING AND 8" DIA. CONNECTION PIPE, EXCLUDING GRATE HOLD DOWN SCREWS, SHALL BE GRAY IRON CONFORMING TO ASTM A48, CLASS 30.

MATERIAL FOR BRACKETS SHALL CONFORM TO ASTM A36.

ALTERNATE BRACKETS ARE NOT ALLOWED.

ALL MATERIAL FOR FLOOR DRAINS TO BE INCLUDED IN THE BID ITEM "FLOOR DRAINS TYPE WF".

ALL MATERIAL FOR DOWNSPOUTS, DOWNSPOUT CONNECTIONS, AND BRACKETS TO BE INCLUDED IN THE BID ITEM "DOWNSPOUT 8-INCH".

8" DIA. DOWNSPOUTS SHALL BE REINFORCED THERMOSETTING RESIN PIPE (RTRP).

TRANSVERSE & LONGITUDINAL SLAB BAR REINFORCEMENT TO BE CUT A MAXIMUM OF 1" CLEAR FROM DRAIN FRAME. DISPLACE BARS WHERE POSSIBLE.

DESIGNER NOTE

ON THE PRESTRESSED GIRDER SHEET, SHOW LOCATION OF HOLES FOR BRACKET ANCHORAGE FROM TOP/BOTTOM AND END OF GIRDER.

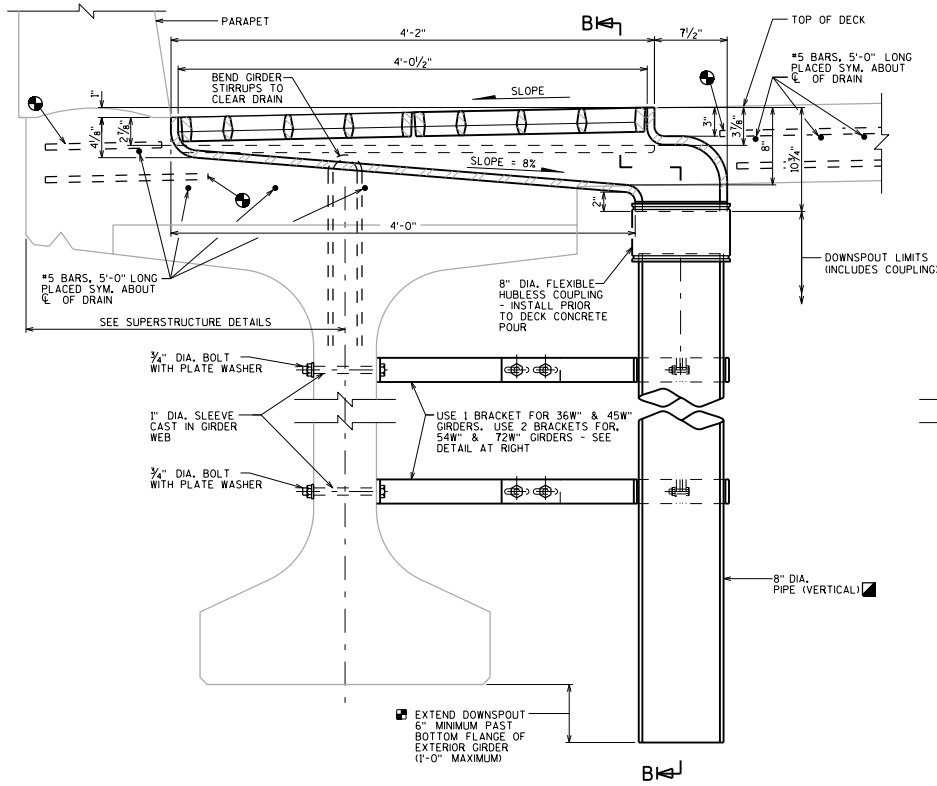

SECTION A-A

DETAIL NOT TO BE USED OVER RAILROADS BECAUSE IT VIOLATES CLEARANCE REQUIREMENTS. CONTACT RAILROADS AND HARBORS SECTION FOR GUIDANCE.

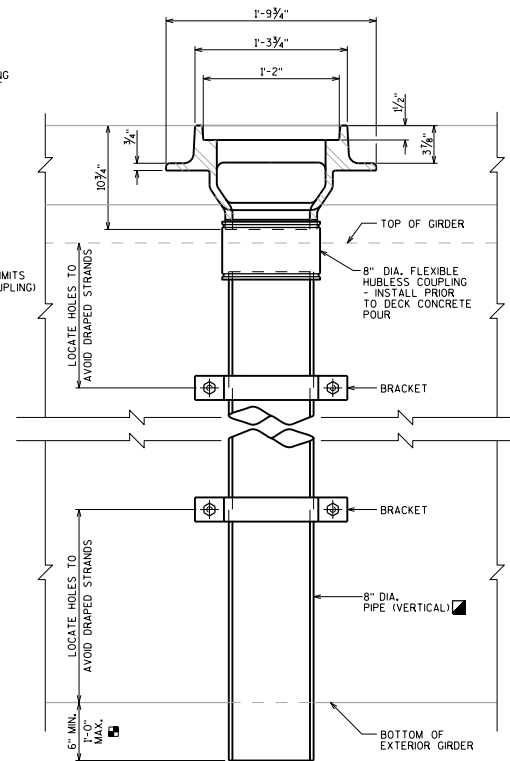

SECTION B-B

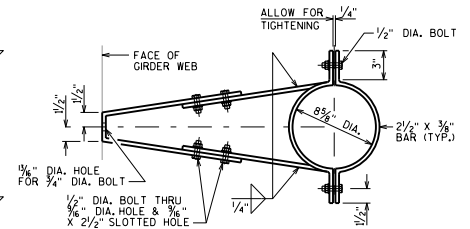

BRACKET DETAIL

FLOOR DRAIN TYPE 'WF'



APPROVED: *Laura Shadewald* DATE: 1-20