

**SECTION THRU FENCE ON PARAPET 'A'**

PROTECTIVE SCREENING MAY BE BENT OR STRAIGHT FOR RAISED SIDEWALKS OR SIDEWALKS SEPARATED FROM TRAFFIC BY A BARRIER. SEE BRIDGE MANUAL 30.3 (D) FOR ADDITIONAL GUIDANCE. SEE STD. 30.07 FOR PARAPET REINFORCEMENT AND DETAILS. SEE STD. 17.01 FOR SIDEWALK REINFORCEMENT AND DETAILS.

CONST. JOINT - STRIKE OFF & LEAVE ROUGH

+0.5% CONSTRUCTION TOLERANCE IN SIDEWALK CROSS SLOPE. THE SIDEWALK CROSS SLOPE SHALL NOT EXCEED 2% WITHOUT PRIOR APPROVAL FROM THE ENGINEER.

WEIGHT OF CHAIN LINK FENCE:  
(BASED ON 8 FT. POST SPACING)  
6 FT. HIGH FENCE = 18 LB / FT  
8 FT. HIGH FENCE = 21 LB / FT

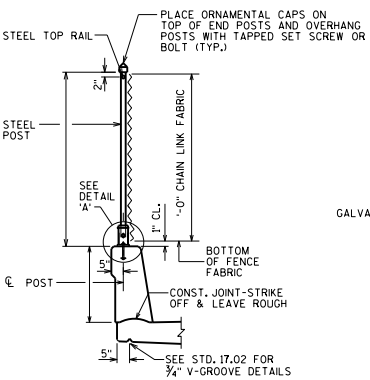

**SECTION THRU FENCE ON SINGLE SLOPE PARAPET**

FOR TRAFFIC BARRIER APPLICATION, USE VERTICAL POST (NO BEND)

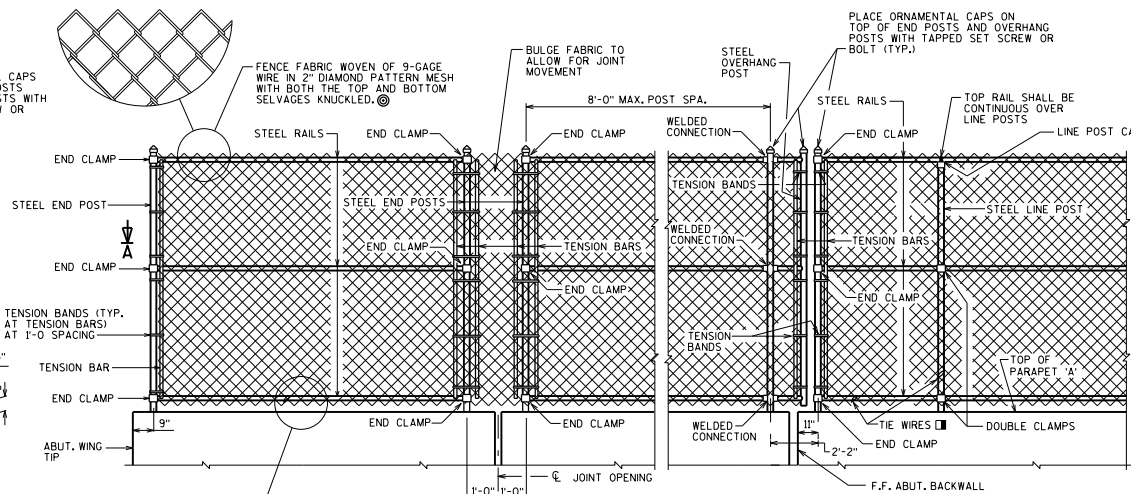

**FENCE PART ELEVATION**

(OUTSIDE VIEW OF PARAPET 'A')

DETAIL "B": EXPANSION JOINT OPENING < 2" OF MOVEMENT. (FOR FIXED JOINTS MAINTAIN TYP. VERT. POST SPA. ACROSS JOINT AND PLACE TENSION BAR ON END POST.) DETAIL "C" MAY BE SUBSTITUTED FOR DETAIL "B".

DETAIL "C": EXPANSION JOINT MAX. OPENING > 2". FOR MAX. JOINT OPENINGS > 6" DESIGN FENCE TO OVERLAP.

**FENCE MEMBER SIZE & WEIGHT**

STEEL FENCE MEMBER	OUTSIDE DIAMETER (INCHES)	WEIGHT (LB/FT)
RAILS	1.660	2.27
END POST	2.875	5.80
OVERHANG POST	2.875	5.80
LINE POST	2.375	3.65
POST SLEEVE	4.000	9.12

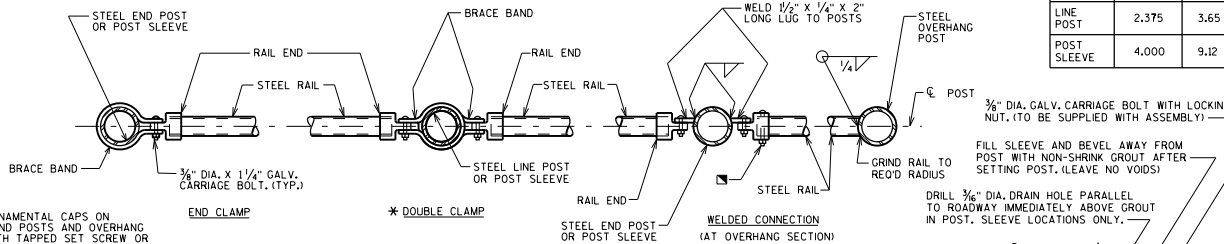

**SECTION A-A**

NOTE: PLACE ALL BOLT HEADS ON SIDE OF FENCE ADJACENT TO PEDESTRIANS

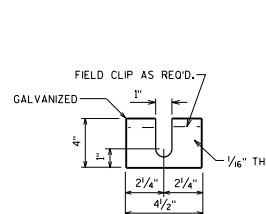

**POST SHIM DETAILS**

SHIMS REQUIRED ONLY WHEN END POSTS AND LINE POSTS ARE WELDED TO BASE PLATES. PROVIDE 4 SHIMS PER POST, USE WHERE REQUIRED FOR ALIGNMENT.

**ANCHOR PLATE**

NOTE: ANCHOR PLATE NOT REQUIRED WHEN ADHESIVE ANCHORS ARE USED.

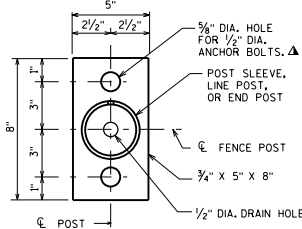

**BASE PLATE**

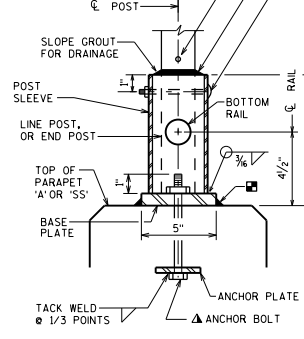

**DETAIL 'A'**

NOTE: IN LIEU OF USING THE POST SLEEVE, THE FENCE POST MAY BE WELDED TO THE BASE PLATE.

**NOTES**

POSTS ARE TO BE SET VERTICAL.

**METALLIC-COATED FENCE SYSTEM:**

ALL FENCE COMPONENTS SHALL BE GALVANIZED STEEL, EXCEPT THE FENCE FABRIC WHICH MAY BE ALUMINUM-COATED STEEL OR GALVANIZED STEEL.

FABRIC SHALL CONFORM TO ASTM A491 OR A392, CLASS 2. STEEL RAILS, POSTS AND POST SLEEVES SHALL CONFORM TO ASTM F1083. STANDARD WEIGHT PIPE (SCHEDULE 40). FITTINGS SHALL CONFORM TO ASTM F626.

THE BID ITEM SHALL BE "FENCE CHAIN LINK - FT."

**POLYMER-COATED FENCE SYSTEM:**

ALL FENCE COMPONENTS SHALL BE GALVANIZED STEEL WITH A COLORED POLYMER-COATING ON THE OUTSIDE.

FABRIC SHALL CONFORM TO ASTM F668, CLASS 2B. STEEL RAILS, POSTS AND POST SLEEVES SHALL CONFORM TO ASTM F1083. STANDARD WEIGHT PIPE (SCHEDULE 40). FITTINGS SHALL CONFORM TO ASTM F626. SEE THE "BRIDGE SPECIAL PROVISIONS" FOR ADDITIONAL DETAILS.

THE COLOR OF POLYMER-COATING FOR THIS STRUCTURE SHALL BE (SPECIFY: DARK GREEN, BROWN OR BLACK), IN ACCORDANCE WITH ASTM F934.

THE BID ITEM SHALL BE "FENCE CHAIN LINK POLYMER - COATED - FT. B - FT."

COMPLETE ANY REQUIRED WELDING OF COMPONENTS BEFORE GALVANIZING.

POST BASE PLATES SHALL BE FLAT WITH ALL SURFACES SMOOTH AND FREE FROM WARP AND ALL EDGES SMOOTH, STRAIGHT AND VERTICAL. ALL PLATE CUTS SHALL BE MACHINE OR MACHINE FLAME CUT.

BASE PLATES, ANCHOR PLATES AND SHIMS SHALL BE ASTM A709, GRADE 36.

ALL POST SPACINGS ARE MEASURED HORIZONTALLY ALONG THE C/L OF THE POST.

CAULK AROUND PERIMETER OF BASE PLATE AND FILL PORTION OF SLOTTED HOLE AROUND ANCHOR BOLT IN SHIM WITH NON-STAINING GRAY NON-BITUMINOUS JOINT SEALER.

ALTERNATE TO DOUBLE CLAMP: USE LINE RAIL CLAMP (BOULEVARD) OR 180° BRACE BAND, WHICH MAY BE USED WHEN THE POSTS ARE EITHER BOLTED TO THE POST SLEEVES OR DIRECTLY WELDED TO THE BASE PLATE.

ANCHOR BOLTS, NUTS AND WASHERS SHALL BE EITHER STAINLESS STEEL OR ASTM 307. IF 307 IS USED, ANCHOR BOLTS, NUTS, AND WASHERS SHALL BE GALVANIZED.

ALTERNATIVE ANCHORAGE: CONCRETE ADHESIVE ANCHORS 1/2"-INCH, EMBEDDED 1" IN CONCRETE. ADHESIVE ANCHORS SHALL CONFORM TO SECTIONS 502.2.12 AND 502.3.14 OF THE STANDARD SPECIFICATIONS.

ATTACH FABRIC TO RAILS, AND TO POSTS WITHOUT TENSION BANDS, WITH THE WIRES (ROUND, 9-GAGE) SPACED AT 1'-0".

BOLT RAIL TO RAIL END TO SECURE OVERHANG SECTION. ALTERNATE IS TO WELD RAIL DIRECTLY TO END POST.

MINIMUM LENGTH OF TOP RAIL BETWEEN SPLICES SHALL BE 20'-0". LOCATE SPLICES NEAR 1/4 POINT OF POST SPACING.

**DESIGNER NOTES**

THE CHAIN LINK FENCE SYSTEM SELECTED FOR THE STRUCTURE SHALL BE A "METALLIC-COATED FENCE SYSTEM" OR A "POLYMER-COATED FENCE SYSTEM".

1" MESH MAY BE USED ON PROTECTIVE SCREENING IN HIGHLY VULNERABLE AREAS, OR AS STATED IN FDM PROCEDURE 11-35-1 FOR PROTECTIVE SCREENING.

PEDESTRIAN RAILING MAY BE USED ON WINGWALL PARAPETS IF CHAIN LINK FENCE DOES NOT CONTINUE BEYOND BRIDGE.

HANDRAILS SHALL BE USED ALONG BRIDGE SIDEWALKS WHERE THE SLOPE OF THE SIDEWALK IS GREATER THAN 5%. TOP OF HANDRAIL GRIPPING SURFACES SHALL BE MOUNTED BETWEEN 30" & 34" ABOVE SIDEWALK SURFACE. USE 30" NEAR SCHOOL ZONES, IF FEASIBLE. HANDRAILS SHALL BE PROVIDED ALONG BOTH SIDES OF SIDEWALK. FOR HANDRAIL DETAILS SEE STANDARD 37.02.

FOR DEAD LOAD PURPOSES, THE SUPERSTRUCTURE DESIGN SHALL ACCOUNT FOR A MAXIMUM 2% SIDEWALK CROSS SLOPE.

**CHAIN LINK FENCE DETAILS**

**BUREAU OF STRUCTURES**

APPROVED: *Laura Shadewald* DATE: 7-21