

* HEADER LENGTH	"A" BARS
TO 11'-0"	6 - #7
OVER 11'-0" - 14'-0"	6 - #8
OVER 14'-0" - 17'-0"	6 - #9
OVER 17'-0" - 20'-0"	6 - #10

\* HEADER LENGTH EQUALS THE DISTANCE BETWEEN  $\frac{1}{2}$  OF WALLS IN ONE CELL MEASURED ALONG THE SKEW.

**DESIGNER NOTES**

SEE BRIDGE MANUAL SECTION 36.2 FOR ADDITIONAL REQUIREMENTS FOR PEDESTRIAN UNDERPASSES AND CATTLE PASSES.

⦿ DETAIL NOT ALLOWED WHEN HAUNCHES ARE REQ'D OR FOR PEDESTRIAN UNDERPASSES. OMIT 1" CHAMFER IF ALTERNATIVE CONSTRUCTION JOINT IS USED.

◆ + = 1'-0" MIN. FOR PEDESTRIAN UNDERPASSES AND SLABS WITH DEPTH OF FILLS < 2'-0"  
+ = 6/2" MIN. OTHERWISE

★ TOP BARS FOR TOP SLAB:  
- FOR + < 10' WITH DEPTH OF FILLS > 2'-0": BARS NOT REQUIRED  
- FOR + > 10': #4 AT 1'-6" MAX. EACH DIRECTION  
- FOR PEDESTRIAN UNDERPASSES: #4 AT 1'-6" MAX. EACH DIRECTION  
- FOR SLABS WITH DEPTH OF FILLS < 2'-0": #4 AT 1'-0" MAX. EACH DIRECTION. USE CLASS 'C' LAPS

▲ FOR PEDESTRIAN UNDERPASSES, PROVIDE A CONTINUOUS SHEET MEMBRANE FOR THE ENTIRE LENGTH OF THE CULVERT IN LIEU OF 18" WIDE RUBBERIZED MEMBRANE WATERPROOFING STRIPS OVER THE JOINTS. CONTACT THE BUREAU OF STRUCTURES FOR THE MOST CURRENT SHEET MEMBRANE SPECIAL PROVISION. INCLUDE THE FOLLOWING NOTE:  
SHEET MEMBRANE WATERPROOFING REQUIRED ON THE WALLS AND ACROSS TOP SLAB FOR ENTIRE CULVERT LENGTH, EXTEND 6" MIN. BELOW THE TOP OF BOTTOM SLAB.

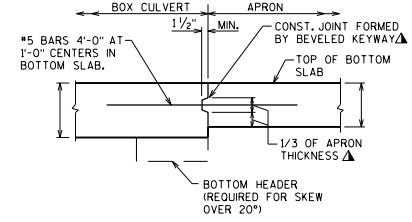
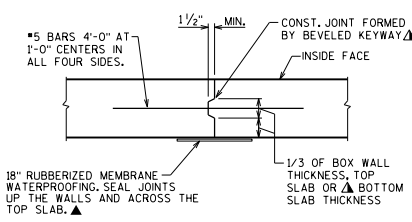
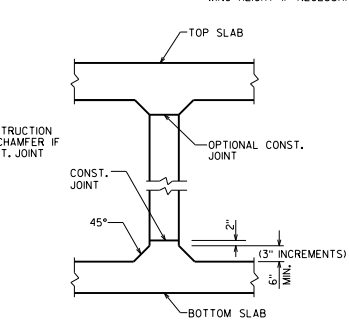
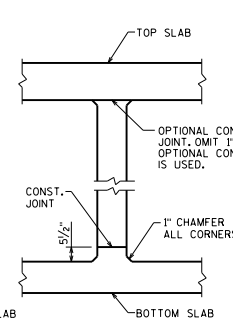
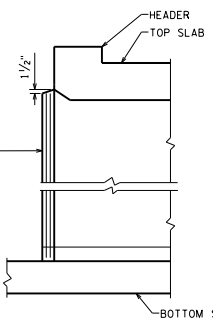
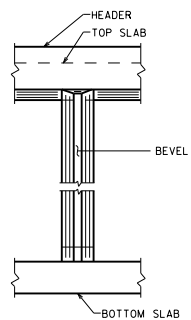

**INLET NOSE CENTER WALL DETAILS**

TYPICAL ALL INLETS

**VERTICAL CONSTRUCTION JOINT**

**APRON CONNECTION DETAIL**

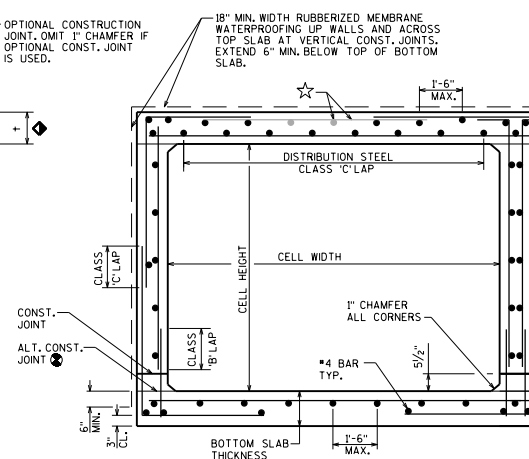
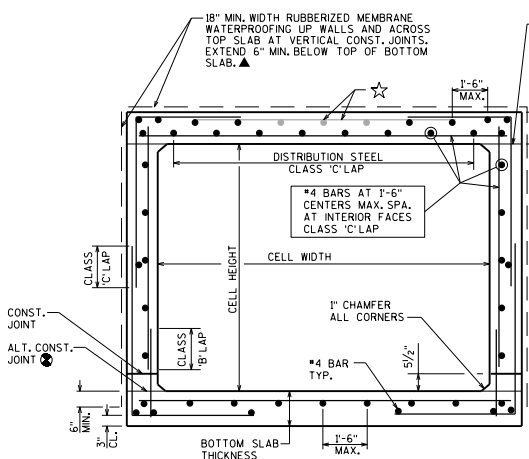

▲ IN LIEU OF CONSTRUCTION JOINTS IN THE BOTTOM SLAB, THE CONTRACTOR MAY USE 2" DEEP SAW CUTS WITHIN 12 HOURS AFTER POURING. #5 BARS 4'-0" AT 1'-0" CENTERS REQUIRED.

OPTIONAL CONSTRUCTION JOINT. OMIT 1" CHAMFER IF OPTIONAL CONST. JOINT IS USED.

**BOX CULVERT DETAILS**



APPROVED: *Laura Shadewald* DATE: 7-23