

JOINT DETAIL

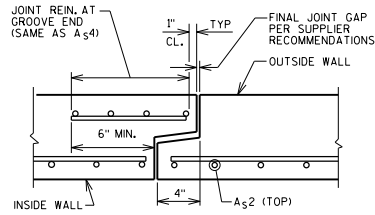

SECTION A-A

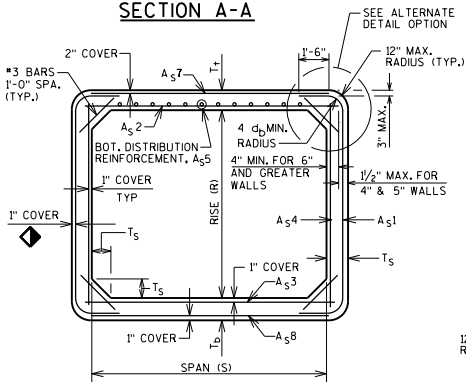

SECTION THRU BARREL

FILL HEIGHT LESS THAN 2 FEET (LONG. REIN. NOT SHOWN FOR CLARITY)

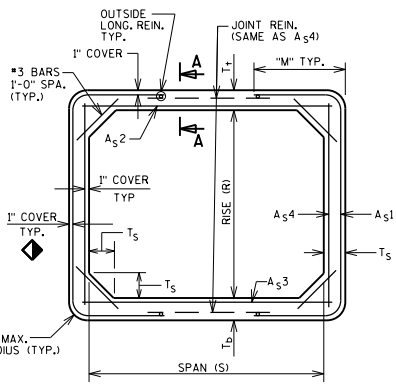

SECTION THRU BARREL

FILL HEIGHT 2'-0" OR GREATER (LONG. REIN. NOT SHOWN FOR CLARITY, UNLESS NOTED OTHERWISE.)

1" OR 3 x WIRE DIAMETER, WHICHEVER IS GREATER

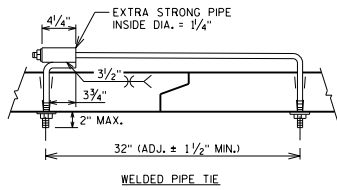

WELDED PIPE TIE

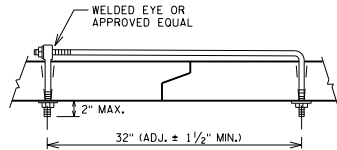

EYE BOLT TIE

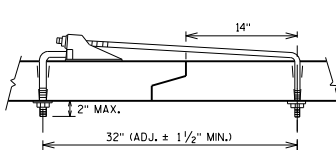

CANOPY TIE

NOTES:
EITHER EYE BOLT TIES, WELDED PIPE TIES, OR CANOPY TIES MAY BE USED. THREADS MAY BE CUT OR ROLLED. TIE NUTS SHALL BE TIGHTENED AS DIRECTED BY THE ENGINEER. (2 TIES REQ'D. PER JOINT.) (TIES TO BE GALVANIZED.)

JOINT TIES

NOTES

DETAILS FOR MATERIALS, FABRICATION, CONSTRUCTION AND DESIGN OF PRECAST BOX CULVERTS NOT SHOWN OR STATED ON THIS DRAWING SHALL BE IN ACCORDANCE WITH THE CURRENT ASTM SPECIFICATION C1577; AASHTO LRFD BRIDGE DESIGN SPECIFICATIONS; WISCONSIN DOT BRIDGE MANUAL; WISCONSIN DOT STANDARD SPECIFICATIONS & APPLICABLE SPECIAL PROVISIONS, EXCEPT THAT THE CONCRETE MIXTURE SHALL CONTAIN NOT LESS THAN 565 LBS. OF CEMENTITIOUS MATERIALS PER CUBIC YARD.

THE DESIGN OF PRECAST BOX CULVERTS WITH ALL FILL HEIGHTS SHALL BE AS STATED IN ASTM C1577.

ALL PRECAST BOX SECTIONS SHALL BE PLACED ON A BEDDING OF "STRUCTURE BACKFILL" OF 6" MINIMUM DEPTH.

THE COVER OF CONCRETE OVER THE REINFORCEMENT SHALL BE 1 INCH OR 2 INCHES AS SHOWN WITH AN ALLOWABLE VARIATION OF -3/8" TO +1/2" INCH.

THE SPACING CTR. TO CTR. OF THE CIRCUMFERENTIAL WIRES SHALL NOT BE LESS THAN 2 INCHES NOR MORE THAN 4 INCHES. THE SPACING CTR. TO CTR. OF THE LONGIT. WIRES SHALL NOT BE MORE THAN 8 INCHES. PROVIDE 0.03 SQ. IN./FT. MINIMUM LONG. REINFORCEMENT AT EACH FACE IN SLABS AND WALLS.

NOT MORE THAN FOUR (4) HOLES MAY BE CAST, DRILLED OR OTHERWISE NEATLY MADE IN THE SHELL OF EACH PIECE OF BOX SECTION FOR HANDLING. THE HOLES SHALL BE TAPERED UNLESS DRILLED. HOLES SHALL BE FILLED WITH PORTLAND CEMENT MORTAR EXCEPT TAPERED HOLES MAY BE FILLED WITH CONCRETE PLUGS SECURED WITH PORTLAND CEMENT MORTAR OR OTHER APPROVED ADHESIVE.

THE JOINT ON THE BOTTOM OF THE CULVERT & THE SIDES OF THE CULVERT FROM THE BOTTOM TO A POINT 1'-0" FROM THE CEILING SHALL BE SEALED WITH A PREFORMED MASTIC. PREFORMED MASTIC MUST CONFORM TO AASHTO MATERIALS SPEC. M18B, TYPE B. A 2'-0" STRIP OF GEOTEXTILE TYPE OF SCHEDULE A SHALL BE PLACED OVER THE JOINTS ON THE TOP AND ON THE SIDES OF THE CULVERT. THE GEOTEXTILE SHALL CONFORM TO SECTION 645.2.2.4 OF THE STANDARD SPECIFICATION. (FABRIC NOT REQUIRED OVER INSIDE WALL JOINTS OF MULTICELL INSTALLATION.)

WHEN TWO OR MORE BARRELS ARE UTILIZED IN PARALLEL FOR MULTICELL INSTALLATIONS THE CLEAR SPACING BETWEEN BARRELS SHALL BE 6 INCHES AND THE SPACE BETWEEN ADJACENT BARRELS FROM TOP OF BEDDING TO TOP OF TOP SLAB SHALL BE FILLED WITH GRADE "B" CONCRETE.

SHOP DRAWINGS SHALL PROVIDE "BOX CULVERT BARREL DATA" WITH REQUIRED AND ACTUAL REINFORCEMENT AREAS.

MATERIAL PROPERTIES:

- PRECAST CONCRETE — f'c = 5,000 P.S.I.
- BAR STEEL REINFORCEMENT — fy = 60,000 P.S.I.
- STEEL REINFORCEMENT (WIRE) — fy = 65,000 P.S.I.

DESIGNER NOTES:

PROVIDE PRECAST DETAILS WHEN SPECIAL DETAILS ARE REQUIRED OR WHEN A PRECAST ONLY DESIGN IS PROVIDED. SEE STD. 36.02 FOR ADDITIONAL INFORMATION.

PROVIDE "BOX CULVERT BARREL DATA" ON CONTRACT PLANS WHEN BOX CULVERT BARREL SECTIONS WARRANT DESIGN REQUIREMENTS BEYOND ASTM C1577 "TABLE A"; SEE BRIDGE MANUAL, SECTION 36.12 FOR SPECIAL CONDITIONS WARRANTING A SEPARATE ANALYSIS.

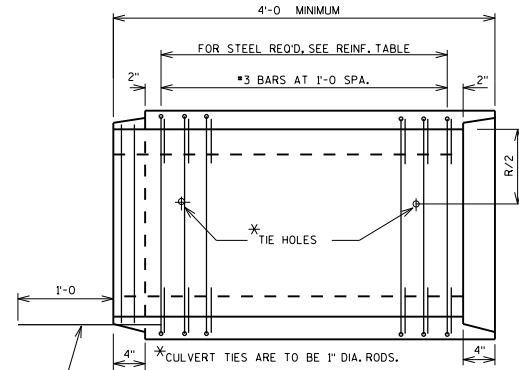

LONGITUDINAL SECTION

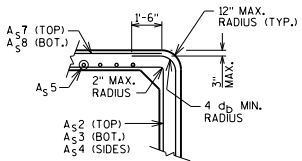

ALTERNATE DETAIL OPTION

BOX CULVERT BARREL DATA

DIMENSIONS					REINFORCEMENT (IN ² /FT)															
FILL HEIGHT (FT)	R (FT)	S (FT)	Ts (IN)	Td (IN)	A5 1		A5 2		A5 3		A5 4		A5 5		A5 7		A5 8			
-	-	-	-	-	REQ'D	ACT.	REQ'D	ACT.	REQ'D	ACT.	REQ'D	ACT.	REQ'D	ACT.	REQ'D	ACT.	REQ'D	ACT.		
-	-	-	-	-	-	-	-	-	-	-	-	-	-	-	-	-	-	-	-	
-	-	-	-	-	-	-	-	-	-	-	-	-	-	-	-	-	-	-	-	

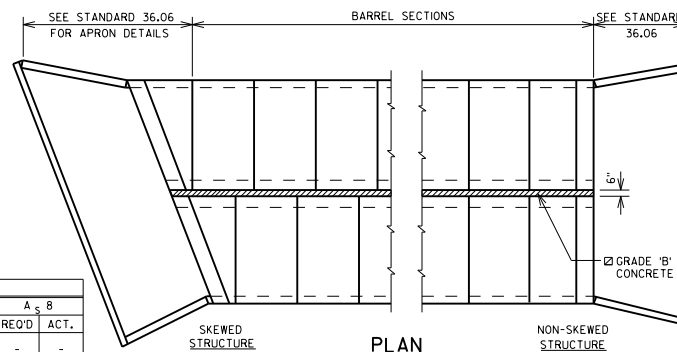

MULTICELL INSTALLATION

PRECAST CONCRETE BOX CULVERT BARREL DETAILS

BUREAU OF STRUCTURES

DATE: _____

APPROVED: *Laura Shadewald* 1-21