

* WELDING IS TO BE COMPLETED USING THE GAS-METAL ARC WELDING (GMAW) PROCESS WITH ERTOS-3 WELDING WIRE AND ARGON-OXYGEN OR CO₂ COVER GAS.

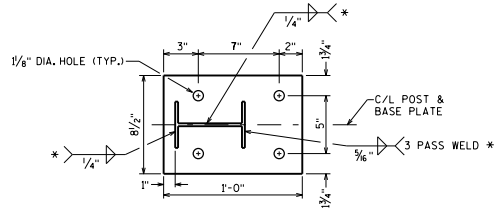

SECTION A-A
POST & BASE PLATE

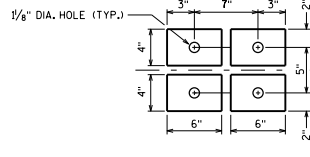

SECTION B-B
(4)-BOTTOM PLATES

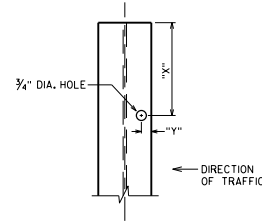

SECTION C-C
HOLE IN POST FLANGE ON APPROACHING TRAFFIC SIDE

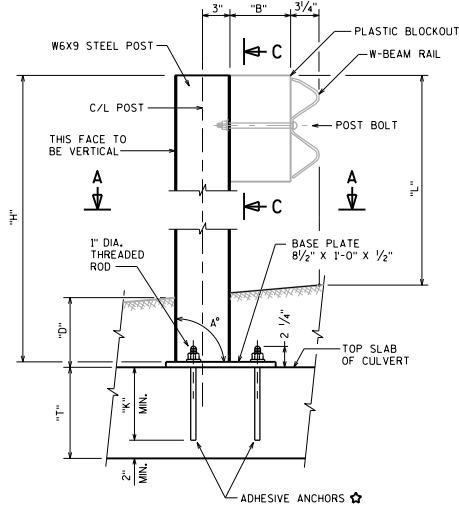

ELEVATION

GUARDRAIL POST ANCHORS TYPE 1

USE FOR THICKNESS "T" OF 11-INCHES OR MORE WITH A MINIMUM EMBEDMENT "K" OF 9-INCHES FOR A CONCRETE STRENGTH (f_c) OF 3,500 PSI.
USE FOR THICKNESS "T" OF 10-INCHES OR MORE WITH A MINIMUM EMBEDMENT "K" OF 8-INCHES FOR A CONCRETE STRENGTH (f_c) OF 4,000 PSI.

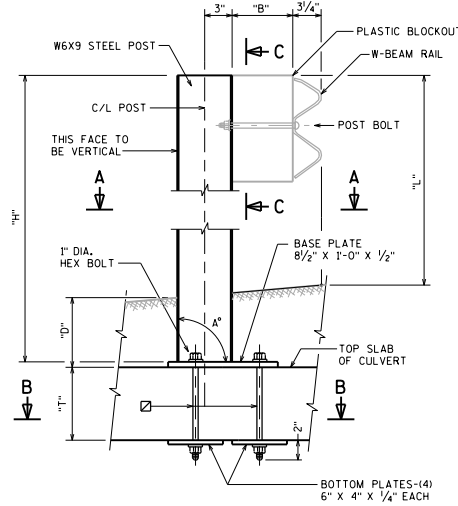

ELEVATION

GUARDRAIL POST ANCHORS TYPE 2

USE FOR THICKNESS "T" OF 8-INCHES OR MORE AND MINIMUM CONCRETE STRENGTH (f_c) OF 3,500 PSI.

GUARDRAIL POST ANCHORAGE SYSTEM

CRITERIA:

USE FOR POSTS WITH "D" EMBEDMENT LESS THAN OR EQUAL TO 4'-0" AND GREATER THAN OR EQUAL TO 9". NOT REQ'D FOR POSTS WITH "D" EMBEDMENT MORE THAN 4'-0". NOT ALLOWED FOR POSTS WITH "D" EMBEDMENT LESS THAN 9".

	"L"	"B"	"X"	"Y"	SOURCE
CLASS "A" GUARDRAIL	2'-4 5/8"	8"	7"	1 3/16"	SDD 14 B 15
MGS GUARDRAIL	2'-7 1/8"	12"	7 7/8"	3/4"	SDD 14 B 42

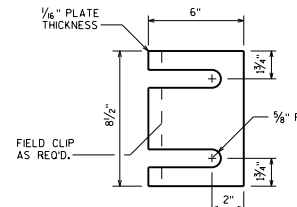

STEEL SHIM DETAIL

4 PER POST

NOTES

DETAILS SHOWN FOR POSTS, PLATES, ANCHORAGE SYSTEM AND INSTALLATION, BLOCKS, AND GUARDRAIL ARE NOT PART OF THE STRUCTURE CONTRACT, BUT ARE BID PER THE ROADWAY DESIGN PLANS.

POST BASE PLATES (AND BOTTOM PLATES IF USED) SHALL BE FLAT WITH ALL SURFACES SMOOTH AND FREE FROM WARP AND ALL EDGES SMOOTH, STRAIGHT AND VERTICAL. ALL PLATE CUTS SHALL BE MACHINE OR MACHINE FLAME CUTS.

CUT BOTTOM OF POST SO THAT POST WILL BE VERTICAL WHEN POST ASSEMBLY IS PLACED ON TOP OF THE CULVERT. ALONG THE ROADWAY THE POST WILL BE NORMAL TO GRADE LINE. HEX BOLTS AND THREADED RODS ARE TO BE FULLY THREADED PERPENDICULAR TO THE BASE PLATE (AND BOTTOM PLATE IF USED).

POST, BASE PLATE (AND BOTTOM PLATE IF USED), AND SHIMS SHALL BE GALVANIZED AFTER FABRICATION.

PRIOR TO GALVANIZING, ALL STEEL POSTS AND PLATES SHALL BE GIVEN A NO. 6 COMMERCIAL BLAST CLEANING BY SSPC SPECS.

ALL MATERIAL USED IN POSTS AND PLATES SHALL BE MADE FROM MATERIAL CONFORMING TO ASTM DESIGNATION A709 GRADE 50 OR 50S.

HEX BOLTS, THREADED RODS, HEX NUTS AND WASHERS SHALL CONFORM TO THE REQUIREMENTS OF ASTM F1554 GRADE 36, AND SHALL BE GALVANIZED. RODS ARE TO BE FULLY THREADED AND BOLTS TO BE THREADED 3", CHAMFER TOP OF BOLTS AND RODS BEFORE THREADING.

ADHESIVE ANCHORS (1-INCH DIA. THREADED ROD) EMBED IN CONCRETE AS DETAILED. CHARACTERISTIC BOND STRENGTH SHALL MEET OR EXCEED 1305 PSIFOR UNCRACKED CONCRETE. SEE STANDARD SPECIFICATION 502.3.14 AND APPLY TO THREADED RODS.

THRU-BOLTS (1-INCH DIA. HEX BOLT), DRILL THRU TOP SLAB WHEN THE CONCRETE HAS ACHIEVED ITS DESIGN STRENGTH (f_c).

STEEL SHIMS MAY BE USED BETWEEN PLATES AND SLAB WHERE REQUIRED FOR ALIGNMENT.

DESIGNER NOTES

CHECK CRITERIA TO SEE IF POST ANCHORAGE SYSTEM IS REQUIRED BASED ON FILL HEIGHT "D" AT POSTS, IF REQUIRED, THEN SELECT WHICH TYPE OF ANCHORAGE (TYPE 1 OR TYPE 2) SHOULD BE USED.

MGS GUARDRAIL SHOULD BE USED FOR ALL NEW SYSTEMS, CONTACT THE ROADWAY DESIGN SECTION TO VERIFY THAT CONDITIONS AT THE SITE OF THE STRUCTURE WOULD NOT REQUIRE A CLASS "A" GUARDRAIL SYSTEM TO BE USED.

POST SPACING IS 3'-1/2" PER FDM SDD 14 B 51. SEE FDM SDD 14 B 51 FOR MINIMUM CLEARANCES FROM EDGES, JOINTS OR OBSTRUCTIONS TO ANCHORAGE SYSTEM FOR TYPE 2 ANCHORAGE. MAKE SURE BOTTOM PLATE IS NOT PLACED AT THE SLOPED HAUNCH BETWEEN THE WALL AND TOP SLAB. SHIFT LOCATION OF POSTS (LONGITUDINALLY ALONG C/L OF POSTS) IF REQUIRED TO MEET SPACING AND CLEARANCE REQUIREMENTS. CHECK WITH ROADWAY DESIGN SECTION TO VERIFY SPACING IS ACCEPTABLE.

SHOW DETAILS AND PERTINENT NOTES FOUND ON THIS STANDARD ON THE STRUCTURE PLANS FOR THE CHOSEN ANCHOR TYPE.

SHOW LOCATION OF POSTS AND SPACING ALONG C/L OF POST IN PLAN VIEW OF STRUCTURE PLANS. LABEL EACH POST (P1, P2, ETC.). SHOW A TABLE PROVIDING THE ESTIMATED LENGTH "Y" OF EACH POST, AND THE ANGLE "A" BETWEEN BASE PLATE AND POST.

IN THE TOP SLAB PROVIDE A MINIMUM OF #4 BARS AT 1'-0" SPACING IN EACH DIRECTION FOR TOP AND BOTTOM MAT WHEN TYPE 1 OR TYPE 2 ANCHORAGE DETAILS ARE USED.

THIS 'MGS' GUARDRAIL SYSTEM AND ANCHORAGE SYSTEM MEET MASH 2016 EVALUATION CRITERIA FOR TEST LEVEL 3 (TL-3).

GUARDRAIL POST ANCHORAGE SYSTEM

BUREAU OF STRUCTURES

DATE: 1-23

APPROVED: *Laura Shadewald*