

14'-0" SPAN

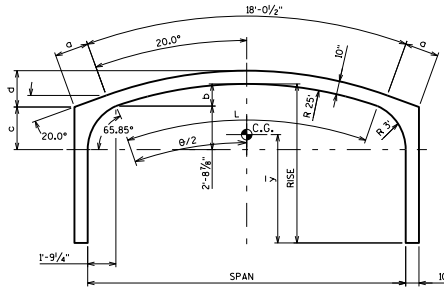

20'-0" TO 24'-0" SPANS

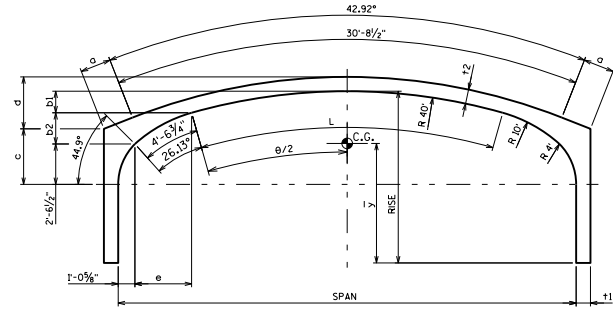

28'-0" TO 42'-0" SPANS

RISE FT	CENTER OF GRAVITY \bar{y} FT					
	SPAN - FT					
	14	20	24	28	36	42
4	3.2					
5	3.9	3.8				
6	4.6	4.6	4.6			
7	5.2	5.3	5.3	5.3		
8	5.8	6.0	6.0	6.0	5.8	
9	6.5	6.6	6.6	6.7	6.5	
10	7.1	7.3	7.3	7.4	7.2	6.9
11				8.0	7.9	7.7
12					8.6	8.4
13					9.3	9.1

RISE FT	AREA OF CONCRETE SECTION SQ. FT					
	SPAN - FT					
	14	20	24	28	36	42
4	15.2					
5	16.5	24.8				
6	17.8	26.5	29.1			
7	19.2	28.2	30.8	39.9		
8	20.5	29.9	32.5	41.9	54.1	
9	21.8	31.5	34.2	43.9	56.4	
10	23.0	33.2	35.8	45.9	58.7	64.7
11				47.9	61.1	67.0
12					63.4	69.4
13					65.7	71.7

	GEOMETRIC PROPERTIES (FT.) (NOT SHOWN ON DRAWING)				
	SPAN - FT				
	20	24	28	36	42
θ	38.43°	48.29°	25.30°	37.93°	47.86°
L	16.77	21.07	17.66	26.48	33.41
a	2.13	4.25	0.00	4.48	4.48
b	1.39	2.19			
b1			0.97	2.17	3.50
b2			1.96	2.40	2.75
c	2.68	2.75	3.76	3.91	4.31
d	2.29	3.01	2.84	4.48	5.66
e			4.07	3.83	3.63
t1			1.00	1.17	1.17
t2			0.83	1.00	1.00

(REFER TO STANDARDS 36.16 FOR REINFORCING DETAILS)

COVER FT	ARCH UNIT PRIMARY REINFORCING (MINIMUM)																	
	14'-0" SPAN 4'-0" TO 10'-0" RISE			20'-0" SPAN 5'-0" TO 10'-0" RISE			24'-0" SPAN 6'-0" TO 10'-0" RISE			28'-0" SPAN 7'-0" TO 11'-0" RISE			36'-0" SPAN 8'-0" TO 13'-0" RISE			42'-0" SPAN 10'-0" TO 13'-0" RISE		
	A1 SQ. IN/FT	A3 SQ. IN/FT	f'c REQ'D. PSI	A1 SQ. IN/FT	A3 SQ. IN/FT	f'c REQ'D. PSI	A1 SQ. IN/FT	A3 SQ. IN/FT	f'c REQ'D. PSI	A1 SQ. IN/FT	A3 SQ. IN/FT	f'c REQ'D. PSI	A1 SQ. IN/FT	A3 SQ. IN/FT	f'c REQ'D. PSI	A1 SQ. IN/FT	A3 SQ. IN/FT	f'c REQ'D. PSI
3	0.66	0.48	5000	0.90	0.78	5000	0.72	0.84	5000	0.96	1.08	5000	1.50	1.68	6000	1.44	1.44	6000
6	0.66	0.48	5000	0.72	0.78	5000	0.72	1.08	5000	0.96	1.32	5000	1.50	1.92	6000	1.44	1.44	6000 ②
9	0.66	0.48	5000	0.72	0.90	5000	0.72	1.44	5000	0.96	1.68	5000 ③	1.50	2.40	6000	1.44	1.92	6000 ④
12	0.66	0.60	5000	0.72	1.08	5000	0.72	1.80	6000 ⑤	0.96	1.80	6000 ⑤	1.50	3.00	6000 ⑤	1.44	2.16	6000 ⑤

- ① SHEAR REINFORCEMENT REQUIRED
- ② SHEAR REINFORCEMENT REQUIRED FOR 6'-0" & 7'-0" RISE
- ③ SHEAR REINFORCEMENT REQUIRED FOR 8'-0" & 9'-0" RISE
- ④ SHEAR REINFORCEMENT REQUIRED FOR 10'-0" & 11'-0" RISE
- ⑤ MINIMUM PRECAST UNIT WIDTH = 3'-11 1/4"

NOTE:
THESE STEEL AREAS ARE SHOWN FOR COVER OF 12'-0" OR LESS.

**PRECAST THREE-SIDED BOX
CULVERT CROSS SECTIONS**

**BUREAU OF
STRUCTURES**

APPROVED: *Laura Shadewald*

DATE:
1-11