

**EXPANSION BEARING REPLACEMENT - STEEL GIRDERS**  
**STEEL BEARINGS**

SEE STANDARD 27.08 FOR BEARING DETAILS

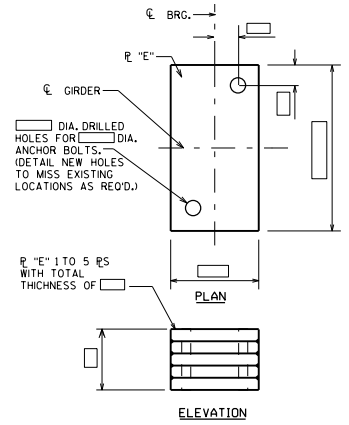

**PLATE 'E' DETAILS**  
 (SEE STD. 40.10 FOR CONCRETE BLOCK ALTERNATE)

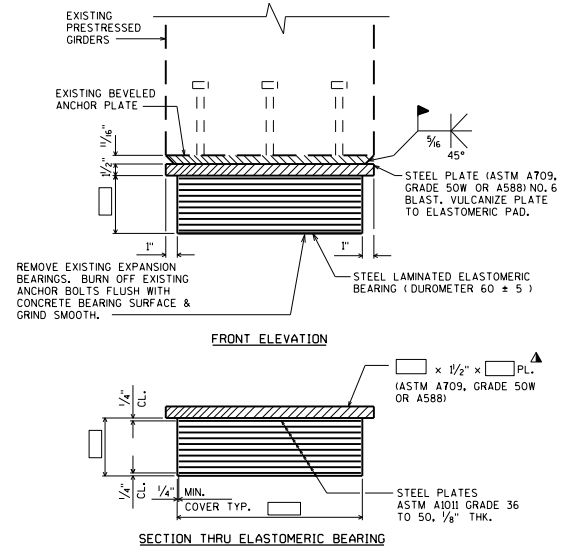

**EXPANSION BEARING REPLACEMENT - PRESTRESSED GIRDERS**  
**ELASTOMERIC BEARINGS**

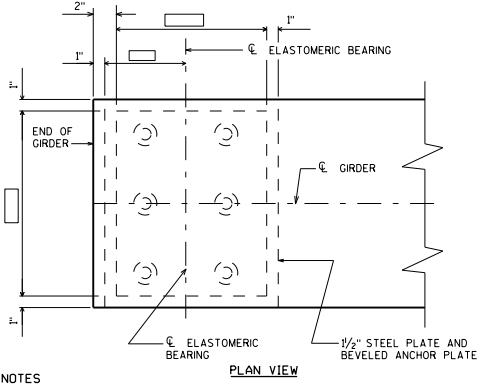

**NOTES**  
 ALL MATERIAL USED FOR BEARINGS SHALL BE PAID AT THE UNIT PRICE BID FOR "BEARING PADS ELASTOMERIC LAMINATED."  
 GRIND EXIST. WELD THAT ATTACHED EXIST. TOP PLATE TO EXIST. BOT. FLANGE. GRIND AFFECTED AREAS SMOOTH.

**DESIGNER NOTES**  
 THE STEEL TOP PLATE THICKNESS MAY BE REDUCED (3/4" MIN.) TO MATCH THE OVERALL EXISTING BEARING HEIGHT. WHEN THE THICKNESS IS REDUCED, THE FOLLOWING NOTE SHALL BE LOCATED ON THE PLANS:  
 "WELDING PROCEDURES SHALL BE ESTABLISHED BY THE CONTRACTOR TO RESTRICT THE MAXIMUM TEMPERATURE REACHED BY SURFACES IN CONTACT WITH ELASTOMER TO 200°F (93°C). TEMPERATURES SHALL BE CONTROLLED BY TEMPERATURE INDICATING WAX PENCILS OR OTHER SUITABLE MEANS APPROVED BY THE ENGINEER."

TOP STEEL PLATE MAY NOT BE OMITTED.  
 ▲ CHECK 27.2.1 ELASTOMERIC BEARINGS IN THE BRIDGE MANUAL FOR REQUIREMENTS TO SEE IF THIS PLATE SHOULD BE TAPERED.  
 DO NOT INCLUDE PRESTRESSED GIRDER SHRINKAGE WHEN DESIGNING BEARINGS FOR BRIDGE REHABILITATION PROJECTS.

SEE STANDARD 27.07 FOR ADDITIONAL INFORMATION.

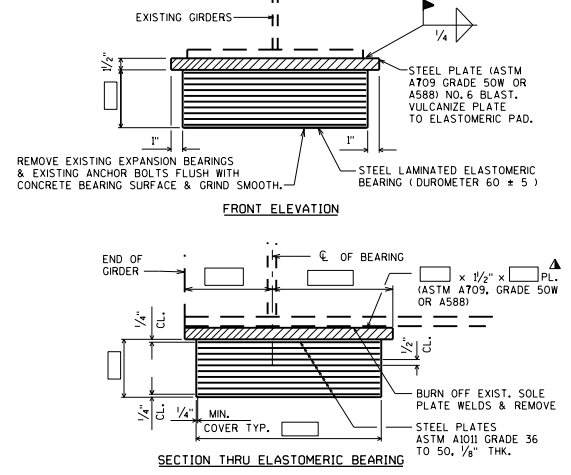

**EXPANSION BEARING REPLACEMENT - STEEL GIRDERS**  
**ELASTOMERIC BEARINGS**

**NOTES & DESIGNER NOTES**  
 SEE "EXPANSION BEARING REPLACEMENT - PRESTRESSED GIRDERS" ON THIS STANDARD.

<b>EXPANSION BEARING REPLACEMENT DETAILS</b>	
	<b>BUREAU OF STRUCTURES</b>
APPROVED: <i>Laura Shadewald</i>	DATE: 1-22