

**TYPICAL HINGE DETAIL FOR WATERTIGHT EXPANSION DEVICE**

NOTE:  
DETAILS NOT SHOWN ARE IDENTICAL TO DETAILS SHOWN  
FOR "FINGER TYPE EXPANSION DEVICE".

\* OPENING TO BE MEASURED IN FIELD

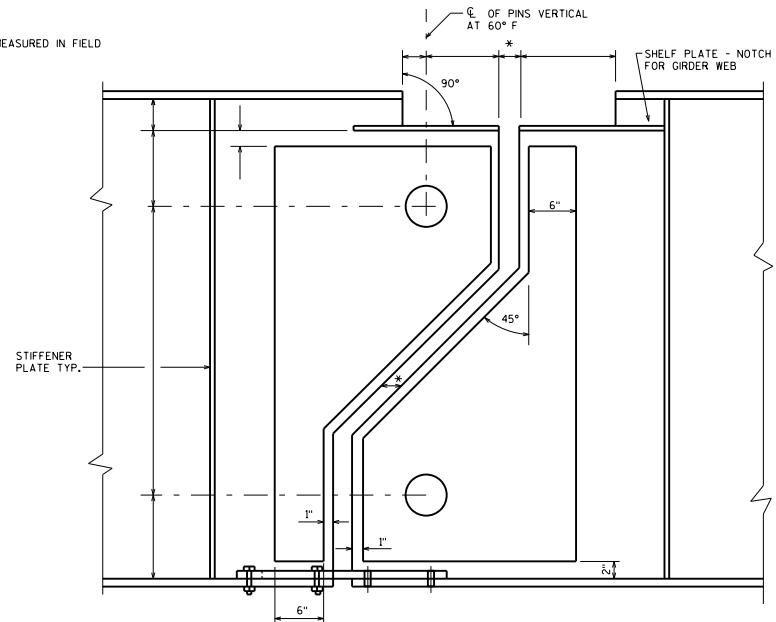

**TYPICAL HINGE DETAIL FOR FINGER TYPE EXPANSION DEVICE**

(HANGER PLATES NOT SHOWN)

**NOTES**

INSIDE HOLES OF HANGER PLATES SHALL BE COATED WITH "BLOXIDE" OR AN APPROVED EQUAL AFTER FINISHING. THE BUSHINGS SHALL HAVE A PRESS FIT INTO HANGER PLATES. THE INSIDE DIAMETER OF THE BUSHING SHALL PROVIDE A CLEARANCE OF 0.005" MINIMUM AND 0.010" MAXIMUM OVER THE FINISHED DIAMETER OF THE PIN. NOTE THAT THE HOLE DIAMETER SHALL BE SMALLER THAN THE BUSHING O.D. BY AT LEAST 0.001" FINISH ANSI 125.

REMOVE EXISTING HANGER PLATES, PINS, AND WIND TRANSFER PLATES AND REPLACE WITH NEW MATERIALS.

BID ITEM SHALL BE "HINGE REPLACEMENT". EACH ALL MATERIAL AND WORK INVOLVED SHALL BE PAID FOR UNDER "HINGE REPLACEMENT".

NEW PINS SHALL MATCH THE DIAMETER OF THE EXISTING PINS. CONTRACTOR TO CONTACT ENGINEER IF CORROSSION AT EXISTING PIN IS PRESENT.

BLAST CLEAN GIRDER WEB AND FLANGES WITHIN 2'-0" OF  $\bar{C}$  OF HINGE IN ACCORDANCE WITH THE STEEL STRUCTURES PAINTING COUNCIL'S SPECIFICATION SSPC-SP6. PAINT AREA CLEANED WITH ORGANIC ZINC RICH PAINT SYSTEM.

HANGER PLATES AND WIND TRANSFER PLATES SHALL BE SHOP PAINTED.

BUSHINGS SHALL BE THE SAME LENGTH AS THE HANGER PLATE THICKNESS.

NON-METALLIC WASHERS SHALL HAVE AN INSIDE DIAMETER OF BETWEEN 0.005" AND 0.010" LARGER THAN THE PIN DIAMETER.

STEEL FOR PINS SHALL CONFORM TO THE REQUIREMENTS OF AASHTO LRFD BRIDGE DESIGN SPECIFICATIONS SECTION 6.4.2 AND ASTM A276. PINS TO BE FINISHED ANSI 63.

■ BUSHINGS SHALL BE CAR-MAX AS MANUFACTURED BY GARLOCK BEARINGS, INC. OR DURALON JOURNAL BEARINGS AS MANUFACTURED BY REYNOLD BEARING DIVISION, OR APPROVED EQUAL. BUSHINGS SHALL HAVE A NOMINAL WALL THICKNESS OF 1/4".

△ NON-METALLIC WASHERS REQUIRED FOR USE AS SPACERS BETWEEN THE PIN PLATES AND THE HANGER PLATES AND THE HANGER PLATES AND NUTS SHALL BE MADE FROM ONE OF THE FOLLOWING MATERIALS:

1. PHENOLIC, CANVAS REINFORCED, MIL-P-15035
2. POLYETHYLENE, HIGH DENSITY, ASTM D4976, CLASS 3
3. ACETAL, FEDERAL SPECIFICATION L-P-392
4. TEFLON TFE, MIL-P-22241A

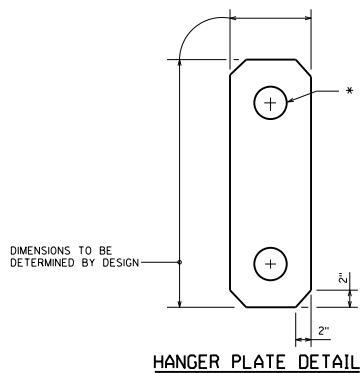

**HANGER PLATE DETAIL**

DIMENSIONS TO BE DETERMINED BY DESIGN

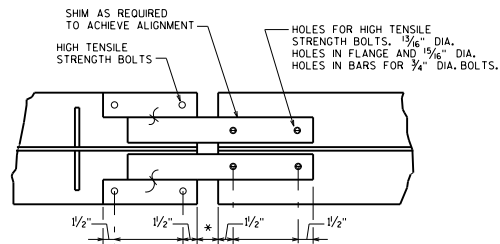

**TYPICAL WIND TRANSFER PLATES DETAIL**

CONTACT AREA OF WIND TRANSFER PLATES TO BE FINISHED ANSI 125.

SHIM AS REQUIRED TO ACHIEVE ALIGNMENT  
HIGH TENSILE STRENGTH BOLTS  
HOLES FOR HIGH TENSILE STRENGTH BOLTS. 3/8" DIA.  
HOLES IN FLANGE AND 5/16" DIA.  
HOLES IN BARS FOR 3/4" DIA. BOLTS.

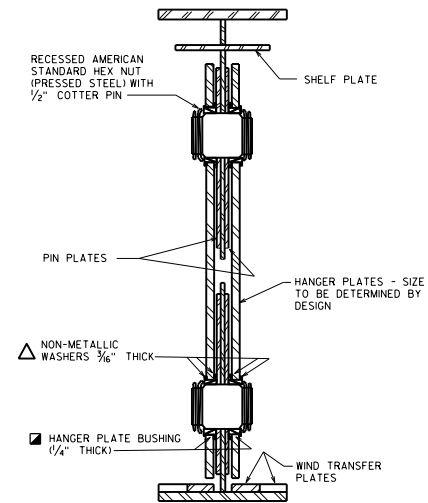

**SECTION THRU HINGE**

**HINGED JOINT REHABILITATION**



APPROVED: *Laura Shadewald*

DATE:  
7-15