

SECTION THRU RAILING ON DECK

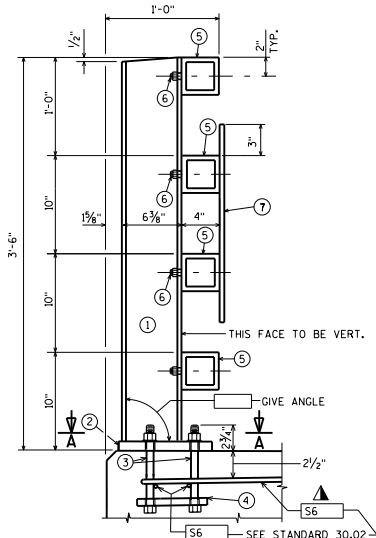

SECTION THRU RAILING ON SIDEWALK

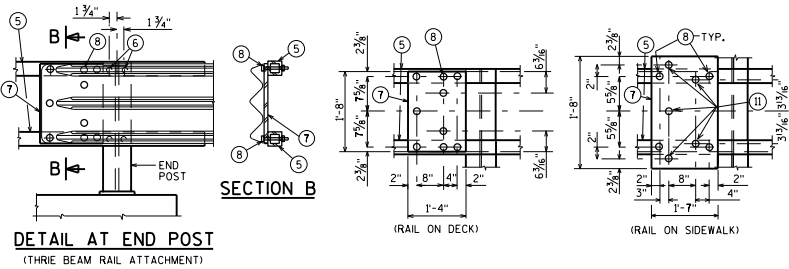

DETAIL AT END POST (THREE BEAM RAIL ATTACHMENT)

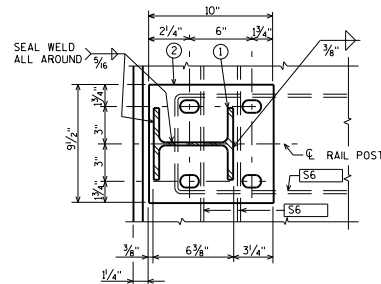

SECTION A

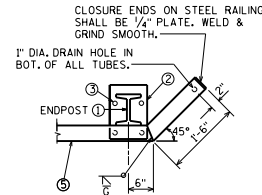

DETAIL FOR END POSTS WITH OR WITHOUT THREE BEAM RAIL ATTACHMENT

(END POST MAY BE LOCATED ON SUPERSTRUCTURE OR WINGWALLS)

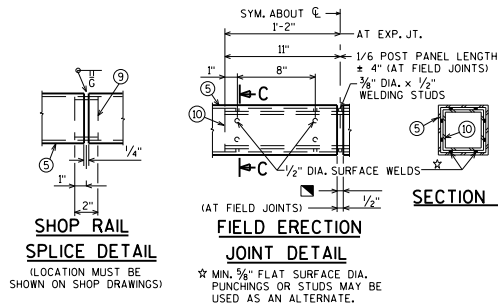

SHOP RAIL SPLICE DETAIL (LOCATION MUST BE SHOWN ON SHOP DRAWINGS)

FIELD ERECTION JOINT DETAIL

MIN. 3/4" FLAT SURFACE DIA. PUNCHINGS OR STUDS MAY BE USED AS AN ALTERNATE.

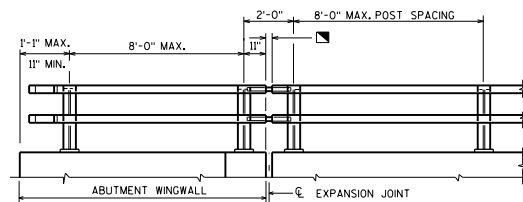

PART ELEVATION OF RAILING

THIS RAILING IS NO LONGER USED AND IS SHOWN FOR INFORMATIONAL PURPOSES ONLY:

FOR 2'-10" RAILING ON DECK:
RAILING WEIGHT = 37 LB/LF (BASED ON 8'-0" POST SPACING.)

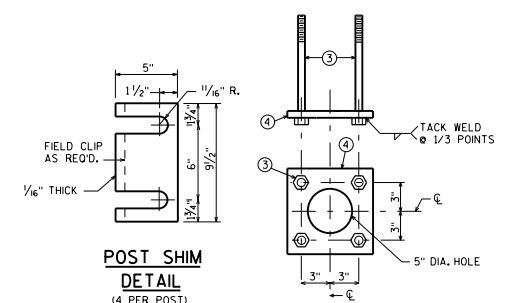

POST SHIM DETAIL (4 PER POST)

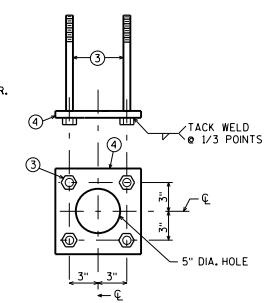

ANCHORAGE DETAIL

LEGEND

- ① W6 x 25 WITH 1/4" DIA. HOLES ON EACH SIDE OF POST FOR STUD NO. 6. CUT BOTTOM OF POST TO MATCH CROSS SLOPE OF ROADWAY (OR SIDEWALK AS APPLICABLE). PLACE POST VERTICAL. PLACE POSTS NORMAL TO GRADE LINE.
- ② PLATE 1" x 9 1/2" x 10" WITH 1/16" x 1/2" SLOTTED HOLES FOR ANCHOR BOLTS NO. 3. WELD TO NO. 1 AS SHOWN.
- ③ A325 - 7/8" DIA. HEX BOLTS (GALVANIZED) WITH A325 NUT & WASHER. 14" LONG AT END POSTS AND AT POSTS ON CONCRETE SLAB SUPERSTRUCTURES WHERE THE SLAB THICKNESS IS > 15". USE 8" LONG AT ALL OTHER LOCATIONS. 4 REQ'D. PER POST. THREAD 3" AND PLACE NORMAL TO PLATE NO. 2. CHAMFER TOP OF BOLTS BEFORE THREADING.
- ④ 1/4" x 8" x 8" FLAT BAR WITH 1/16" DIA. HOLES FOR ANCHOR BOLTS NO. 3
- ⑤ TS 4 x 4 x 0.25 STRUCTURAL TUBING, CONFORMING TO ASTM DESIGNATION A501OR A500 GRADE B. ATTACH TO NO. 1 WITH STUDS NO. 6.
- ⑥ 3/8" DIA. x 1/2" LONG SHOP WELDED STUDS WITH HEX NUT AND 2" WASHERS (2 REQ'D. AT EACH RAIL TO POST LOCATION.)
- ⑦ PLATE 3/8" x 1'-4" (1'-7" ON SDWK.) x 1'-8". BOLT TO RAIL AS SHOWN IN DETAIL. REQUIRED AT THREE BEAM GUARD RAIL ATTACHMENTS ONLY. PLACE SYMMETRICALLY ABOUT TUBES NO 5.
- ⑧ 1" DIA. HOLES IN PLATE NO. 7 & TUBES NO. 5 FOR 7/8" DIA. A325 BOLTS W/HEX NUTS AND WASHERS.
- ⑨ SQUARE SLEEVE FABRICATED FROM 1/4" PLATE. PROVIDE "SLIDING FIT" WITH A MINIMUM OUT TO OUT DIMENSION OF 3 13/32".
- ⑩ TS 3 x 3 x 0.25 x 12'-4" AT EXPANSION JOINTS & (1'-10" AT FIELD JOINTS) LONG. PROVIDE 3/8" DIA. SURFACE WELDS ON ALL SIDES AS SHOWN. GRIND WELDS TO FIT FREE INTO I.D. OF NO. 5. PROVIDE 3/8" DIA. x 1/2" WELDING STUDS ON TOP AND BOTTOM SURFACES AT CENTERLINE.
- ⑪ 7/8" DIA. x 1/2" LONG THREADED SHOP WELDED STUDS. (REQ'D. FOR SDWK. RAIL ONLY.)

NOTES

BID ITEM SHALL BE "RAILING TUBULAR TYPE F B--", WHICH INCLUDES ALL ITEMS SHOWN.
RAILING SHALL BE FABRICATED IN LENGTHS THAT INCLUDE 3 OR 4 POSTS.
POST BASE PLATES SHALL BE FLAT WITH ALL SURFACES SMOOTH AND FREE FROM WARP AND ALL EDGES SMOOTH, STRAIGHT AND VERTICAL. ALL PLATE CUTS SHALL BE MACHINE OR MACHINE FLAME CUT.
FOR RAILING NOT TO BE PAINTED, ALL MATERIAL EXCEPT ANCHORAGE DETAIL NO. 4 SHALL BE GALVANIZED AFTER FABRICATION. PRIOR TO GALVANIZING, ALL STEEL RAILING POSTS & STEEL TUBING SHALL BE GIVEN A NO. 6 BLAST CLEANING BY SSPC SPECIFICATIONS.
FOR RAILING TO BE PAINTED, ALL MATERIAL EXCEPT ANCHORAGE DETAIL NO. 3 & 4. SHALL BE PAINTED WITH A THREE-COAT ZINC RICH EPOXY SYSTEM. PRIOR TO PAINTING, ALL STEEL RAILING POSTS & STEEL TUBING SHALL BE GIVEN A NO. 11 NEAR WHITE BLAST CLEANING BY SSPC SPECIFICATIONS.
ALL MATERIALS USED IN FABRICATION SHALL BE MADE FROM MATERIALS CONFORMING TO ASTM A709 GRADE 36 UNLESS NOTED OTHERWISE.
FILL BOLT SLOT OPENINGS IN POST SHIMS AND PLATE NO. 2 WITH NON-STAINING GRAY NON-BITUMINOUS JOINT SEALER.
STEEL POST SHIMS MAY BE USED UNDER POSTS WHERE REQ'D. FOR ALIGNMENT.
PLACE FIRST BOTTOM LONGITUDINAL BAR CLEAR OF DRIP GROOVE.

TUBULAR STEEL RAILING TYPE 'F'

BUREAU OF STRUCTURES

APPROVED: *Laura Shadewald* DATE: 7-16