

▲ LENGTH SHOWN FOR BAR IS AN AVERAGE LENGTH AND SHOULD ONLY BE USED FOR BAR WEIGHT CALCULATIONS. SEE BAR SERIES TABLE FOR ACTUAL LENGTHS.

**BILL OF BARS FOR ABUTMENT PARAPETS**

BAR MARK	COM.	ABUT.	ABUT.	LENGTH	BENT	BAR SERIES	LOCATION
R501	X			4'-7"	X		PARAPET VERT.
R502	X			2'-4"	X		PARAPET VERT.
R503	X			4'-7"	X		PARAPET VERT.
R804	X						PARAPET HORIZ.
R505	X			6'-6"	X		PARAPET VERT.
R506	X				X		PARAPET HORIZ.
R507	X			5'-8"	X	▲	PARAPET VERT.
R808	X				X		PARAPET HORIZ.
S501	X			4'-5"	X		PARAPET VERT.
S502	X			2'-4"	X		PARAPET VERT.
S503	X			4'-2"	X		PARAPET VERT.

◆ ROADWAY OPENING OR 2 1/2" MIN. FOR EXPANSION JOINT. USE 1/2" OPENING WITH FILLER FOR A1 ABUTMENTS

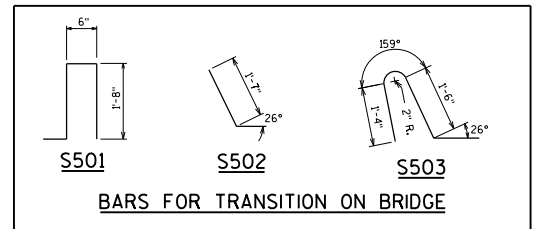
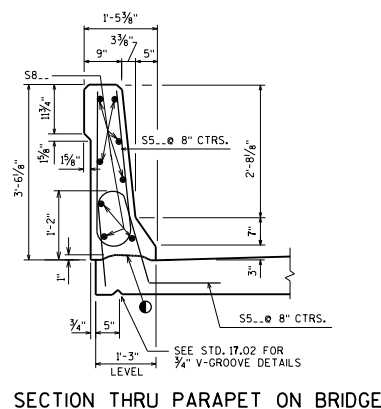
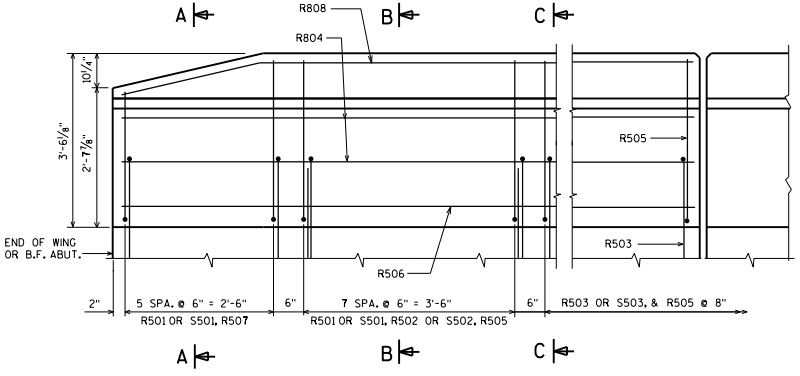
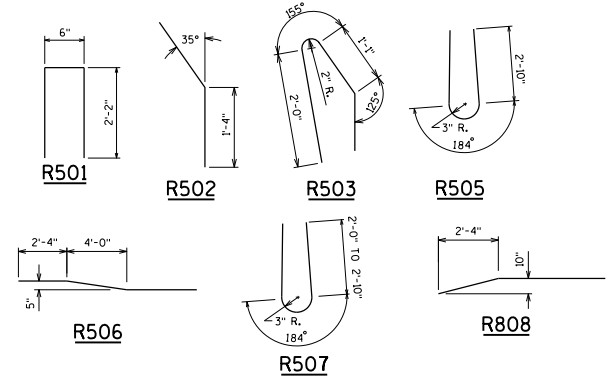
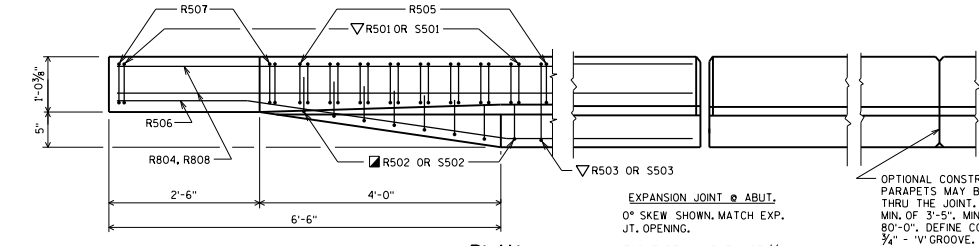

AREA = 3.16 SF WEIGHT = 474 LB/FT

● CONST. JOINT - STRIKE OFF AS SHOWN.

▲ R502 BARS MAY BE PLACED AFTER CONCRETE IS POURED BUT BEFORE INITIAL SET HAS TAKEN PLACE. USE CARE TO PLACE R502 OR S502 BARS CORRECTLY ALONG TRANSITION OF PARAPET.

▽ R501 AND R503 BARS TO BE TIED TO WING STEEL BEFORE WING IS POURED.

A R503 BAR MAY BE USED IN LIEU OF A S503 BAR ADJACENT TO THE PAVING NOTCH ON TYPE A1 ABUTMENTS.

**SLOPED FACE PARAPET 'HF'**

**BUREAU OF STRUCTURES**

APPROVED: *Laura Shadewald* DATE: 1-19