



# Wisconsin Department of Transportation

## Division of Transportation Systems Development

Bureau of Project Development  
4802 Sheboygan Avenue, Rm 601  
P O Box 7916  
Madison, WI 53707-7916

Telephone: (608) 266-1631  
Facsimile (FAX): (608) 266-8459

December 7, 2017

### NOTICE TO ALL CONTRACTORS:

**Proposal 12: 2195-03-70, WISC 20180 009**  
**West Wells Street, City of Milwaukee**  
**Milwaukee River Bridge B-40-544**  
**USH 18**  
**Milwaukee County**

### Letting of December 12, 2017

This is Addendum No. 02, which provides for the following:

#### Special Provisions:

Revised Special Provisions	
Article No.	Description
45	Bearing Maintenance B-40-544, Item SPV.0060.501
65	Bridge Electrical Work, Item SPV.0105.505

#### Plan Sheets:

Revised Plan Sheets	
Plan Sheet	Plan Sheet Title (brief description of changes to sheet)
91	PIER 1 (Deleted note about clean up in east and west pier pit area)
157	ONE-LINE DIAGRAM (Changed Non Fused Disconnect to Fused Disconnect)
158	HPU RELAY CABINET (Changed HPU Relay Cabinet Size)
159	EXISTING CONTROL CONSOLE (Added New Switch for Remote Operation)

The responsibility for notifying potential subcontractors and suppliers of these changes remains with the prime contractor.

Sincerely,

*Mike Coleman*

Proposal Development Specialist  
Proposal Management Section

**ADDENDUM NO. 02**

**2195-03-70**

**December 7, 2017**

**Special Provisions:**

**45. Bearing Maintenance B-40-544, Item SPV.0060.501.**

*Replace entire article language with the following:*

**A Description**

This special provision describes raising the girders, removing the existing bearings at the piers, furnishing and installing new bearing base plate shims, blast cleaning and painting the bearing components in the shop, replacing the anchor bolts, reassembling the bearings to provide full contact bearing for the existing fixed span girders, and for installing caulk around the perimeter of the bearings in accordance with the plans and as hereafter provided.

**B Materials**

Furnish a complete epoxy coating system from the department's approved product list. The color of epoxy shall be white and the urethane coating material shall match the color for the finish coating material for all existing steel bearings shall be the same color and semi-gloss finish as provided under bid item Painting Epoxy System (B-40-544). Supply the engineer with the product data sheets before any coating is applied. The product data sheets shall indicate the mixing and thinning directions, the recommended spray nozzles and pressures, the minimum drying time for shop applied coats, and the recommended procedures for coating galvanized bolts, nuts, and washers.

Bearing base plate shims shall be stainless steel.

**C Construction**

**C.1 General**

Raise and support the existing steel girder and remove the bearing plate and existing shim pack. Leave the top plate as is, attached to the girder bottom flange. Pull out the existing anchor bolts and install the new anchor bolts in the existing holes. Replace the bottom shim pack with new stainless steel full width shims. Blast-clean in the shop all bearing components while disassembled to a near white finish and paint all bearing components with one of the coating systems specified above. Install existing rehabilitated bottom bearing plate using new anchor bolts and new nuts and washers, and reassemble the bearing assembly. As required, use adequate containment methods to contain material resulting from preparation of painted steel surfaces for painting. Replace anchor bolts with new galvanized anchor bolts. Perform any concrete repairs required under the beam seats while the girder is temporarily supported for bearing maintenance.

**C.2 Coating Application**

Apply paint in the shop in a neat workmanlike manner, and in accordance to the manufacturer's instructions and recommendations.

**D Measurement**

The department will measure Bearing Maintenance B-40-544 as each individual bearing acceptably completed.

**E Payment**

The department will pay for measured quantities at the contract unit price under the following bid item:

ITEM	DESCRIPTION	UNIT
------	-------------	------

NUMBER  
SPV.0060.501

Bearing Maintenance B-40-544

Each

Payment is full compensation for jacking up the girders; removing, cleaning, painting, installing new stainless steel shims; reinstalling bearings and replacing the anchor bolts; and for furnishing all labor, tools, equipment, materials, and incidentals necessary to complete the contract work.

**65. Bridge Electrical Work, Item SPV.0105.505**

*Replace paragraph three under section titled A.1 General with the following:*

The work includes removal of the existing hydraulic power unit (HPU) and its existing control relay and associated wiring. Remove and dispose of existing conduit and wiring for the existing HPU and the existing generator. Existing traffic gate houses are being removed and salvaged including all components (motors, limits, arms, lights, etc.). Gate houses for installation on the bridge are to be picked up from the City of Milwaukee to be rehabilitated and installed on the structure. New gate arms including lights will be supplied by the City of Milwaukee for installation on the rehabilitated gate housings.

*Replace paragraphs one and two under section titled C.9 Dry Type Transformers with the following:*

Furnish dry type transformers suitable for indoor mounting in the quantity, voltage, phase, KVA rating, and method of mounting as shown on the drawings. Transformers shall be UL 1561 listed and labeled "Suitable for non-sinusoidal current loads."

Transformers shall be Class AA. The temperature rating shall rise above ambient, as listed below. Primary taps shall be as listed below.

Below Normal Three phase less than 25 kva	Above Normal Two 5 percent	Temp. Below Rise	115°C
Three phase 25 kva and larger	Four 2 1/2 percent	Two 2 1/2 percent	80°C

*Replace paragraph one under section titled C.13.3 HPU Relay Cabinet with the following:*

The Relay cabinet shall be of neat, substantial construction, arranged as shown on the plans. It shall be fabricated from not less than No. 12 gauge stainless steel properly formed, and suitable reinforced by steel angles to provide adequate strength. The door shall be 12 gauge stainless steel. The cabinet shall be Hoffman Engineering Co. catalog number A- A723612LP3PT with back panel or equal by Hammond Industries. The general arrangement may be varied to fit specific equipment used. The cabinet dimensions shall not be exceeded. The cabinet shall have a nameplate attached to the left hand door. Nameplates shall be not less than 1 inch high and shall be attached with stainless steel screws. Cabinet shall be mounted where shown on the plans and secures to the support shelf bracket using 3/4" stainless steel bolts and hardware.

*Add the following section after the section titled C.20 Guarantee:*

**C.21 Traffic Signals**

Each traffic signal assembly shall consist of a single-face, two-section, alternately flashing red signal head assemblies for vertical mounting as indicated on the plans. Each traffic light section shall be a weatherproof unit consisting of a separate polycarbonate housing with hinged lens holder and polycarbonate hood. The lens shall be 12 inches in diameter and shall conform to the specifications of the Institute of Transportation Engineers. The reflector shall be silvered glass, and the socket shall

be focused for use with a 116-watt, traffic signal lamp. The lens shall be encased in a weather-proof seal. Each traffic light assembly shall be LFE Automatic Signal Corp. series A-7003 or approved equal by B & B Roadway Manufacturing.

Each traffic light section shall be provided with a tunnel-type, detachable visor. Lenses shall have a combination of directing and diffusing prisms on the inner side of the lens to concentrate maximum candle power in the center of the beam. Lenses shall be furnished with a continuous soft rubber gasket completely surrounding the edge of the lens. The front portion of the gasket shall seat tightly against the door and the back portion shall press against the reflector support ring when the door is closed. The reflector assembly shall be hinged to the signal body.

The traffic signal flasher unit shall be mounted within the Relay Cabinet as shown on the plans. The flasher shall be rated 120 volts AC, consisting of two (2) flashing circuits. Each circuit shall flash .50 seconds on and .50 seconds off. Flasher output circuits shall be rated at 5 amps minimum at 120 volts. Flasher shall be B&B Roadway Manufacturing catalog number 120A60DFWS-ROA or approved equal.

The traffic signal poles shall consist of a tapered steel shaft complete with anchor base, anchor bolts, handhole, cast pole top, and a flange plate near the top of the pole for mounting the mast arm. Round tapered support beams shall be complete with a mounting flange plate, hanger clamp and outlet having a 1-inch ID rubber grommet for wiring each signal and a removable cap.

The shaft shall be made of 1 length steel fabricated from a minimum 7 Ga. high strength cold rolled steel and shall conform to the requirements of ASTM A595 Grade A. A 4"x8" handhole complete with cover shall be welded into the shaft 15" above the base. A J-hook wire support shall be welded near the top of the shaft. Furnish an opening near the top of the shaft to provide a cable entrance from the shaft into the bracket mast arm.

A one-piece cast steel anchor base of adequate strength, shape and size, shall conform to ASTM A27 Grade 65-35 and shall be secured to the lower end of the shaft by two continuous electric arc welds, approximately 2" apart. Provide four holes in the base to receive the anchor bolts, four holes for ventilation in the body of the base and four tapped holes for attaching the covers.

The tapered support beams shall be made of 7 Ga. steel and conform to ASTM A 595 Grade A. A flange plate shall telescope the large end of the beam and be welded by two continuous electric arc welds. The flange plate shall have four holes for the flange bolts conforming to ASTM A325. Each support beam shall have wire outlet holes on the bottom surface, with rubber grommet, located at each signal position. Poles shall be by Union Metal, Valmont or approved equal.

### **C.22 Traffic Gate Housing**

Remove and salvage existing Traffic Gate Housings from the bridge including all components (motors, limits, arms, lights). Traffic gates to be installed as part of the rehabilitation will be supplied by the City of Milwaukee. The contractor shall repair, clean, paint, and install the traffic gate houses on the bridge after the new concrete sidewalks have been installed. The gate house repairs include repairs to the steel housing at areas of advanced section loss. Electrical/mechanical components of the gates to be installed on the bridge will be functional and shall not require rehab work.

New gate arms and gate arm lights will be provided by the City for installation by the contractor on the rehabilitated traffic gate houses.

The contractor shall pick up the traffic gate housing and gate arms from the City of Milwaukee Field Headquarters at 3850 North 35<sup>th</sup> Street.

The traffic gate houses shall be sandblasted and painted in accordance with the special provision Structure Repainting Recycled Abrasive B-40-544. The top coat color shall match the color of the tubular bridge railing.

Contractor shall provide all bolts, screws or other fastenings used in the gate arm assembly and for connection to the gate stand, including the anchor bolts, shall be of corrosion-resisting metal or shall be hot-dip galvanized.

New wiring shall be installed to the existing cabinets and controls in the bridge house for gate operation.

**Plan Sheets**

The following 8½ x 11-inch sheets are attached and made part of the plans for this proposal:  
Revised: 91, 157, 158, and 159.

END OF ADDENDUM

STATE PROJECT NUMBER  
2195 - 03 - 70

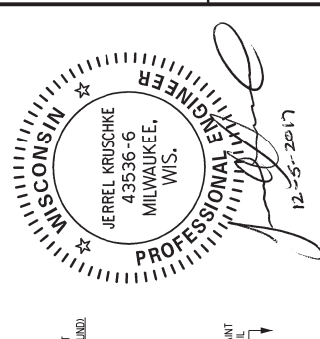
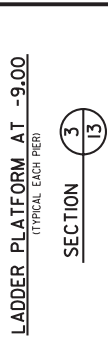
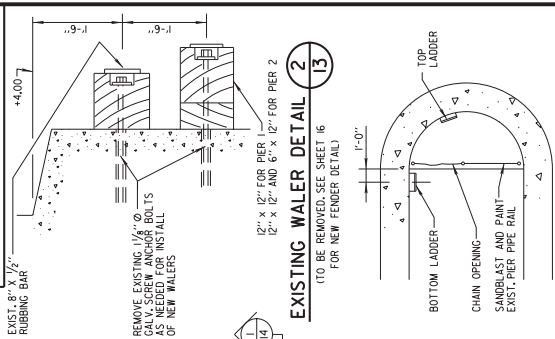

NO.	DATE	REVISION	BY
1	02/25/17	REMOVED NOTE	JDT

STATE OF WISCONSIN  
DEPARTMENT OF TRANSPORTATION

STRUCTURE B-40-544

DRAWN BY: [blank]  
D.B.I. (D.C.)

PLANS - J.D.T.  
H.O.S.

SHEET 13 OF 58

Addendum No. 02  
ID 2195-03-70  
Revised Sheet 91  
December 7, 2017

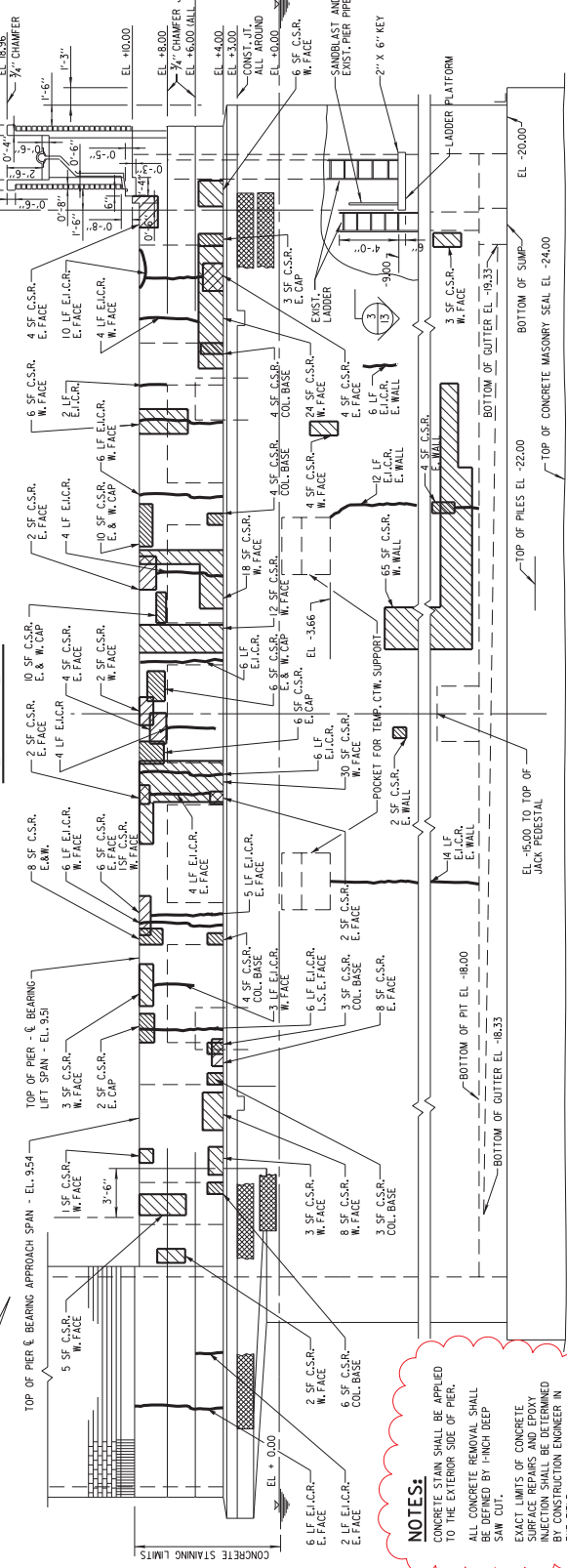
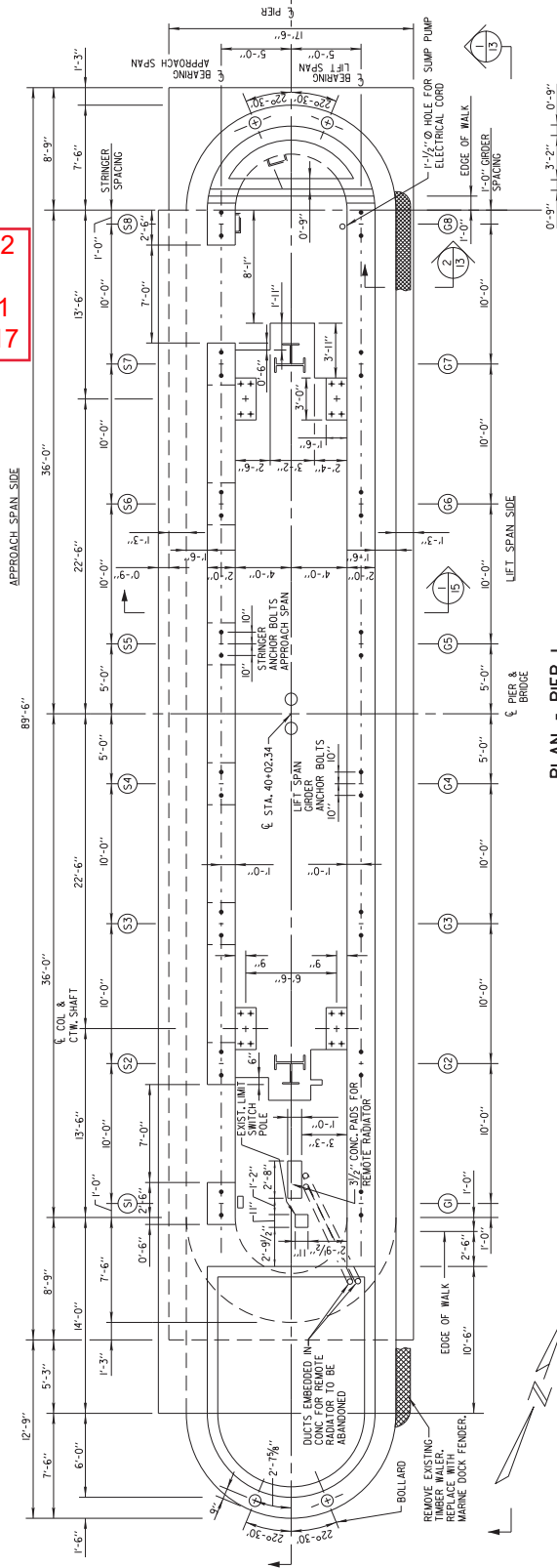

WILLIAM C. DUBER  
12/07/17

Addendum No. 02  
ID 2195-03-70  
Revised Sheet 157  
December 7, 2017

William C. Decker  
12/07/17



12.6.2017

NO.	DATE	REVISION	BY
1	12/5/17	DISCONNECT SWITCH	JOS

STATE OF WISCONSIN  
DEPARTMENT OF TRANSPORTATION

STRUCTURE B-40-544

DRAWN SHS  
BY  
PLANS JOS  
EXT.

SHEET E4 OF E12  
157

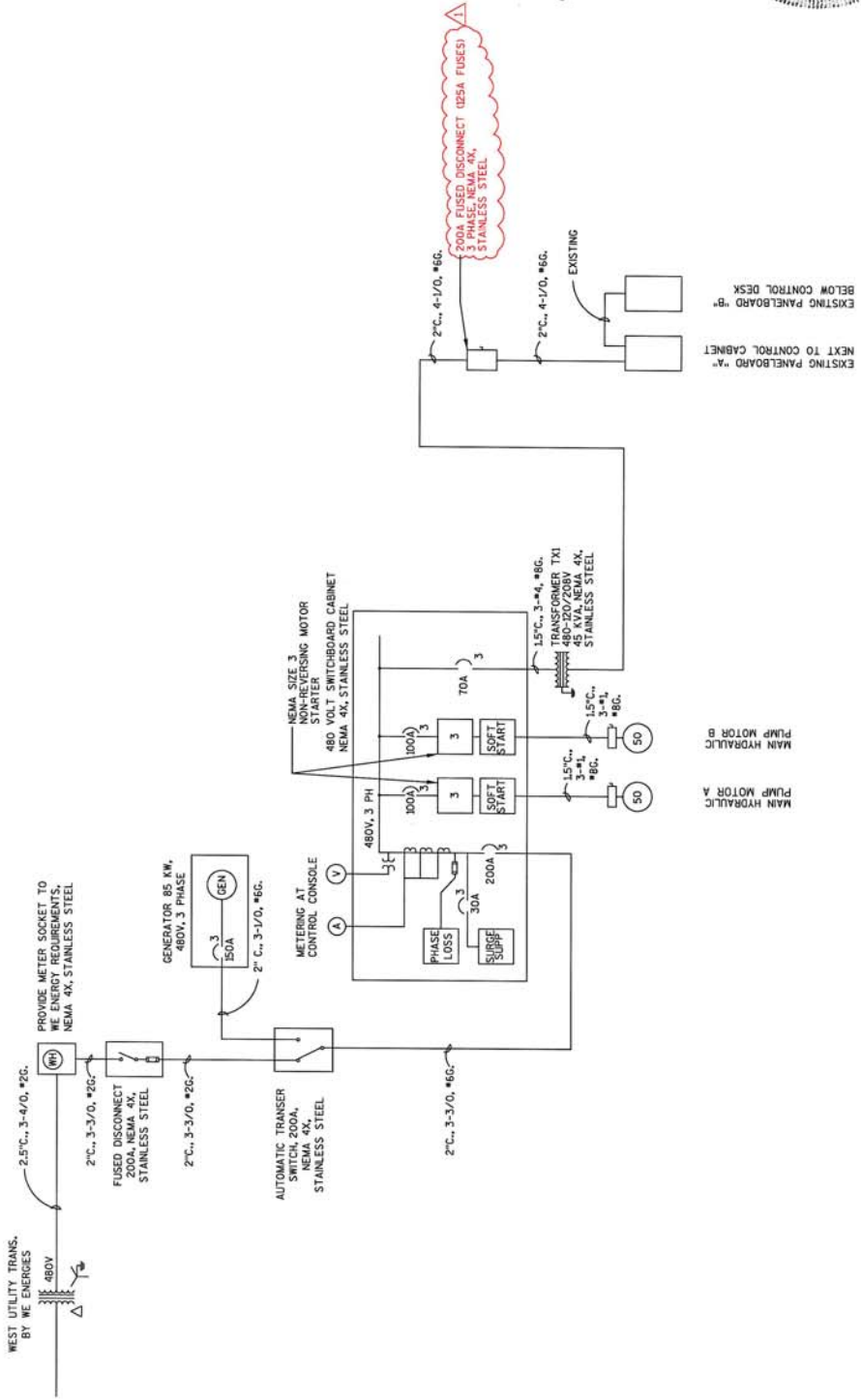

- NOTES:**
1. PROVIDE INSIGHT DISCONNECT SWITCHES FOR MOTORS SIZED IN ACCORDANCE WITH THE NEC AND LOCAL CODES. MOUNT SWITCHES NEAR MOTORS AS REQUIRED.
  2. PROVIDE GENERATOR SIZING DESIGN CALCULATION REPORT INDICATING ABILITY TO START AND RUN LOADS. ONLY ONE HYDRAULIC MOTOR TO OPERATE WHEN GENERATOR IS RUNNING.

EXISTING PANELBOARD "A"  
NEXT TO CONTROL CABINET

EXISTING PANELBOARD "B"  
BELOW CONTROL DESK

MAIN HYDRAULIC  
PUMP MOTOR B

MAIN HYDRAULIC  
PUMP MOTOR A

Addendum No. 02  
ID 2195-03-70  
Revised Sheet 158  
December 7, 2017

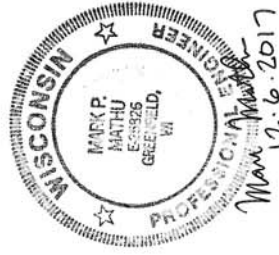

*William C. Decker*<sup>SR</sup>  
12/07/17

NO. DATE	REVISION	BY
12/25/17	CABINET SIZE CHANGE	JCS
STATE OF WISCONSIN DEPARTMENT OF TRANSPORTATION		
STRUCTURE B-40-544		
DRAWN BY	CHKD. BY	PLANS JCS
HPU RELAY CABINET		SHEET 158 OF 158

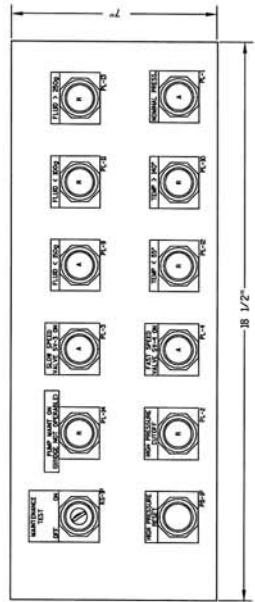
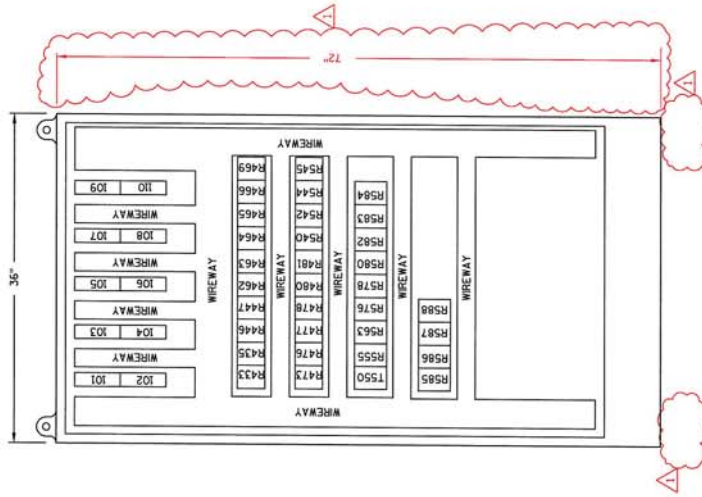

HPU RELAY CABINET  
(MOUNT ON EQUIPMENT ROOM LEVEL)

CABINET SHALL BE HOFFMAN ENGINEERING  
PANEL NO. 7580L3PPT WITH BACK  
PANEL OF APPROVED EQUAL.



Addendum No. 02  
ID 2195-03-70  
Revised Sheet 159  
December 7, 2017

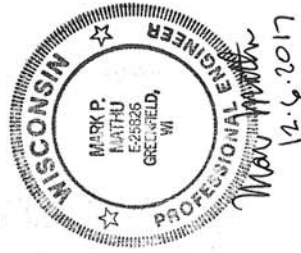

ITEM NO.	QUANTITY	DESCRIPTION
1	1	SWITCH 1/2 AMPERE LIGHT MICRO PMLC13176E-00
2	1	PILOT LIGHT - RED MICRO PMLC13134C-00
3	1	PILOT LIGHT - GREEN MICRO PMLC13135D-00
4	1	KEY LOCK SWITCH C.K. 1025071512 **NEED ALIASE
5	1	SWITCH 1/2 AMPERE LIGHT MICRO PMLC13135E-00
6	1	ILLUMINATED DIGITAL CLOCK LED. 205P14M
7	1	4 DIGIT COUNTER BUZZER 6-413-RFP-1M
8	1	SWITCH 1/2 AMPERE LIGHT MICRO PMLC13132B-M2-00
9	1	ILLUMINATED AC VOLT METER WESL. GA332 0-300V
10	1	ILLUMINATED AMP METER WESL. GA332 0-200A
11	1	SWITCH MICRO PFS E22-02-CC
12	1	INTERCOM
13	1	INSTRUCTION NAME PLATE, STAINLESS STEEL 1 1/2" X 1 1/2"
14	2	PILOT LIGHT - RED MICRO PFL 2137-800
15	6	PILOT LIGHT - GREEN MICRO PFL 2137-800
16	2	PILOT LIGHT - GREEN MICRO PFL 2134-800
17	1	SPWM INDICATOR
18	1	20V SPK 500L. OPM MSY
19	1	SWITCH MICRO PFM 310-800
20	1	PILOT LIGHT - GREEN-RED MICRO PMLC13168E-00
21	1	KEY LOCK SWITCH C.K. 1025071522 **NEED ALIASE
22	1	SWITCH MICRO PFS R232-D-800
23	1	PILOT LIGHT - RED MICRO PFL 2137-800
24	1	KEY LOCK SWITCH C.K. 1025071512 **NEED ALIASE
25	1	SWITCH MICRO PFM 310-800
26	1	KEY LOCK SWITCH C.K. 1025071527 **NEED ALIASE

NAME PLATES

- 1) 3" X 4" DASH DOWN
- 2) 3" X 4" DASH DOWN
- 3) 3" X 4" DASH DOWN
- 4) 3" X 4" DASH DOWN
- 5) 3" X 4" GATE FULLY DOWN
- 6) 3" X 4" DASH DOWN
- 7) 3" X 4" DASH DOWN
- 8) 3" X 4" DASH DOWN
- 9) 3" X 4" DASH DOWN
- 10) 3" X 4" DASH DOWN
- 11) 3" X 4" DASH DOWN
- 12) 3" X 4" DASH DOWN
- 13) 3" X 4" DASH DOWN
- 14) 3" X 4" DASH DOWN
- 15) 3" X 4" DASH DOWN
- 16) 3" X 4" DASH DOWN
- 17) 3" X 4" DASH DOWN
- 18) 3" X 4" DASH DOWN
- 19) 3" X 4" DASH DOWN
- 20) 3" X 4" DASH DOWN
- 21) 3" X 4" DASH DOWN
- 22) 3" X 4" DASH DOWN
- 23) 3" X 4" DASH DOWN
- 24) 3" X 4" DASH DOWN
- 25) 3" X 4" DASH DOWN
- 26) 3" X 4" DASH DOWN
- 27) 3" X 4" DASH DOWN
- 28) 3" X 4" DASH DOWN
- 29) 3" X 4" DASH DOWN
- 30) 3" X 4" DASH DOWN
- 31) 3" X 4" DASH DOWN
- 32) 3" X 4" DASH DOWN
- 33) 3" X 4" DASH DOWN
- 34) 3" X 4" DASH DOWN
- 35) 3" X 4" DASH DOWN
- 36) 3" X 4" DASH DOWN
- 37) 3" X 4" DASH DOWN
- 38) 3" X 4" DASH DOWN
- 39) 3" X 4" DASH DOWN
- 40) 3" X 4" DASH DOWN
- 41) 3" X 4" DASH DOWN
- 42) 3" X 4" DASH DOWN
- 43) 3" X 4" DASH DOWN
- 44) 3" X 4" DASH DOWN
- 45) 3" X 4" DASH DOWN
- 46) 3" X 4" DASH DOWN
- 47) 3" X 4" DASH DOWN
- 48) 3" X 4" DASH DOWN
- 49) 3" X 4" DASH DOWN
- 50) 3" X 4" DASH DOWN
- 51) 3" X 4" DASH DOWN
- 52) 3" X 4" DASH DOWN
- 53) 3" X 4" DASH DOWN
- 54) 3" X 4" DASH DOWN
- 55) 3" X 4" DASH DOWN
- 56) 3" X 4" DASH DOWN
- 57) 3" X 4" DASH DOWN
- 58) 3" X 4" DASH DOWN
- 59) 3" X 4" DASH DOWN
- 60) 3" X 4" DASH DOWN
- 61) 3" X 4" DASH DOWN
- 62) 3" X 4" DASH DOWN
- 63) 3" X 4" DASH DOWN
- 64) 3" X 4" DASH DOWN
- 65) 3" X 4" DASH DOWN
- 66) 3" X 4" DASH DOWN
- 67) 3" X 4" DASH DOWN
- 68) 3" X 4" DASH DOWN
- 69) 3" X 4" DASH DOWN
- 70) 3" X 4" DASH DOWN
- 71) 3" X 4" DASH DOWN
- 72) 3" X 4" DASH DOWN
- 73) 3" X 4" DASH DOWN
- 74) 3" X 4" DASH DOWN
- 75) 3" X 4" DASH DOWN
- 76) 3" X 4" DASH DOWN
- 77) 3" X 4" DASH DOWN
- 78) 3" X 4" DASH DOWN
- 79) 3" X 4" DASH DOWN
- 80) 3" X 4" DASH DOWN
- 81) 3" X 4" DASH DOWN
- 82) 3" X 4" DASH DOWN
- 83) 3" X 4" DASH DOWN
- 84) 3" X 4" DASH DOWN
- 85) 3" X 4" DASH DOWN
- 86) 3" X 4" DASH DOWN
- 87) 3" X 4" DASH DOWN
- 88) 3" X 4" DASH DOWN
- 89) 3" X 4" DASH DOWN
- 90) 3" X 4" DASH DOWN
- 91) 3" X 4" DASH DOWN
- 92) 3" X 4" DASH DOWN
- 93) 3" X 4" DASH DOWN
- 94) 3" X 4" DASH DOWN
- 95) 3" X 4" DASH DOWN
- 96) 3" X 4" DASH DOWN
- 97) 3" X 4" DASH DOWN
- 98) 3" X 4" DASH DOWN
- 99) 3" X 4" DASH DOWN
- 100) 3" X 4" DASH DOWN

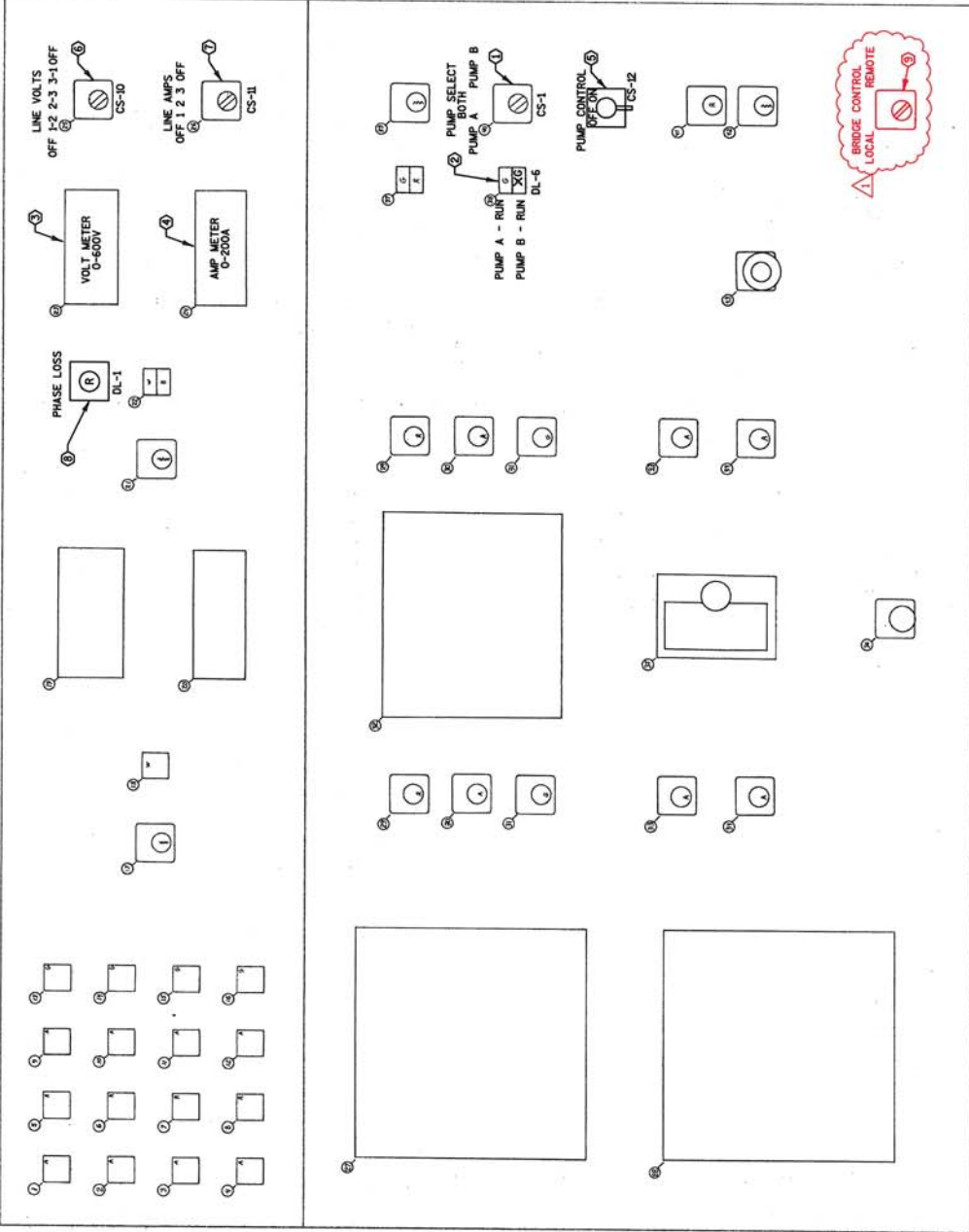

KEYED NOTES

- 1) REMOVE EXISTING SWITCH, PROVIDE NEW SWITCH AND NAMEPLATE.
- 2) REMOVE EXISTING PILOT LIGHTS AND PROVIDE NEW PILOT LIGHTS AND NAMEPLATE.
- 3) PROVIDE NEW ILLUMINATED WESLER VOLTMETER 0-600V, WESLER AMP METER 0-200A, WESLER DIGITAL CLOCK AND BUZZER IN EXISTING RELAY CABINET.
- 4) CALIBRATE AMP METERS TO READ CORRECT AMPS AT 480V. CONNECT TO METERS 480V SWITCHBOARD CABINET, BEING EXISTING CT'S IN EXISTING RELAY CABINET.
- 5) PROVIDE NEW SWITCH WITH NAME PLATE "OFF - ON".
- 6) PROVIDE NEW VOLTAGE PHASE SELECTOR SWITCH AND NAMEPLATE.
- 7) PROVIDE NEW AMPMETER SELECTOR SWITCH AND NAMEPLATE.
- 8) PROVIDE NEW DESK LIGHT FOR PHASE LOSS MONITOR AND NAMEPLATE.
- 9) PROVIDE NEW SWITCH WITH NAME PLATE "BRIDGE CONTROL" "LOCAL-REMOTE".

GENERAL NOTES

1. BACKGROUND DRAWING FROM 1984 SHOP DRAWING. DRAWING NO. 4748-2

*William C. Dehn* SR

12/07/17

NO. DATE	ADD SELECTOR SWITCH	JOS
	REVISION	BY

STATE OF WISCONSIN  
DEPARTMENT OF TRANSPORTATION

STRUCTURE B-40-544

EXISTING CONTROL CONSOLE

159

