

SUP
PROJECT ID:
WITH: N/A

1180-44-70

COUNTY:
ASHLAND & IRON

DECEMBER 2022

ORDER OF SHEETS

Section No.	Title
1	Title
2	Typical Sections and Details
3	Estimate of Quantities
3	Miscellaneous Quantities
4	Right of Way Plan
5	Plan and Profile
6	Standard Detail Drawings
7	Sign Plates
8	Structure Plans
9	Computer Earthwork Data
9	Cross Sections

TOTAL SHEETS = 152

STATE OF WISCONSIN
DEPARTMENT OF TRANSPORTATION
PLAN OF PROPOSED IMPROVEMENT
ODANAH - SAXON
GOVERNMENT ROAD TO EAST COUNTY LINE
USH 2
ASHLAND & IRON COUNTIES

STATE PROJECT	FEDERAL PROJECT	
	PROJECT	CONTRACT
1180-44-70	WISC 2023116	1

STATE PROJECT NUMBER
1180-44-70

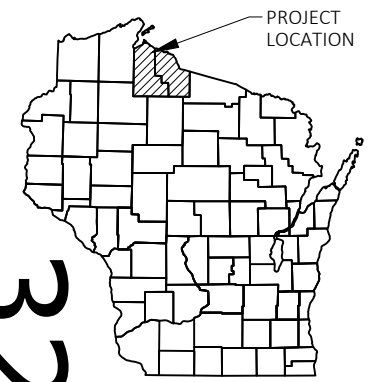

BEGIN PROJECT
STA 441+89
Y = 329716.43
X = 550914.34

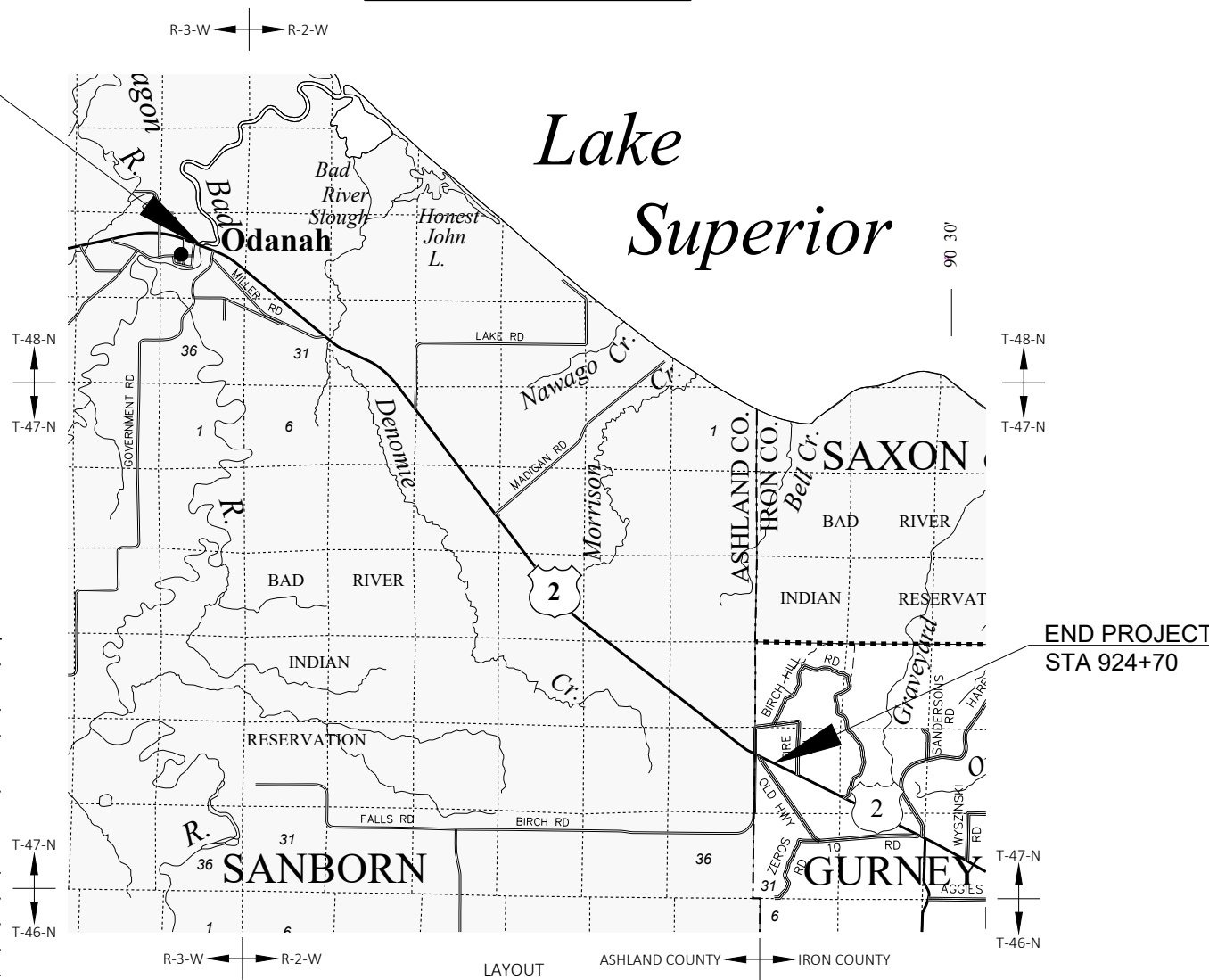

END PROJECT
STA 924+70

DESIGN DESIGNATION

A.A.D.T.	2015	=	4700
A.A.D.T.	2033	=	6000
D.H.V.		=	457
D.D.		=	60/40
T.		=	18.9%
DESIGN SPEED		=	55 MPH
ESALS		=	1,400,000

CONVENTIONAL SYMBOLS

PLAN	PROFILE
CORPORATE LIMITS	GRADE LINE
PROPERTY LINE	ORIGINAL GROUND
LOT LINE	MARSH OR ROCK PROFILE (To be noted as such)
LIMITED HIGHWAY EASEMENT	SPECIAL DITCH
EXISTING RIGHT OF WAY	GRADE ELEVATION
PROPOSED OR NEW R/W LINE	CULVERT (Profile View)
SLOPE INTERCEPT	UTILITIES
REFERENCE LINE	ELECTRIC
EXISTING CULVERT	FIBER OPTIC
PROPOSED CULVERT (Box or Pipe)	GAS
COMBUSTIBLE FLUIDS	SANITARY SEWER
	STORM SEWER
	TELEPHONE
	WATER
MARSH AREA	UTILITY PEDESTAL
	POWER POLE
WOODED OR SHRUB AREA	TELEPHONE POLE

LAYOUT
SCALE 0 2 MI
TOTAL NET LENGTH OF CENTERLINE = 9.144

HORIZONTAL POSITIONS SHOWN ON THIS PLAN ARE WISCONSIN COORDINATE REFERENCE SYSTEM (WISCRS), ASHLAND COUNTY, NAD83 (2011), IN U.S. SURVEY FEET. POSITIONS SHOWN ARE GRID COORDINATES, GRID BEARINGS, AND GRID DISTANCES. GRID DISTANCES ARE THE SAME AS GROUND DISTANCES. ELEVATIONS ARE REFERENCED TO NAVD 88 (2012). GPS DERIVED ELEVATIONS ARE BASED ON GEOID 12A.

STATE OF WISCONSIN DEPARTMENT OF TRANSPORTATION	
PREPARED BY	Surveyor _____ WISDOT
Designer	_____ MITCHELL FINNEGAN
Project Manager	_____ PHILIP KEPPERS
Regional Examiner	_____ JENNIFER OLDENBURG
Regional Supervisor	_____ JEFFREY OLSON

APPROVED FOR THE DEPARTMENT
DATE: 7/28/2022 *Philip Keppers*
(Signature)

UTILITIES

BAD RIVER BAND OF LAKE SUPERIOR CHIPPEWA -WATER
PHILIP LIVINGSTON
54173 BIRCH STREET
PO BOX 39
ODANAH, WI 54861
PHONE: (715)685-7878 EXT. 1692 (OFFICE)
PHONE: (715) 292-5339 (MOBILE)
EMAIL: WaterSewerSupvr@badriver-nsn.gov

ASTREA - COMMUNICATIONS LINE
ANDREW HEIGL
105 KENT ST.
PO BOX 190
IRON MOUNTAIN, MI 49801
PHONE: (906) 776-2609 (OFFICE)
PHONE: (906) 221-7536 (MOBILE)
ANDY.HEIGL@ASTREACONNECT.COM

BAD RIVER BAND OF LAKE SUPERIOR CHIPPEWA -SEWER
PHILIP LIVINGSTON
54173 BIRCH STREET
PO BOX 39
ODANAH, WI 54861
PHONE: (715)685-7878 EXT. 1692 (OFFICE)
PHONE: (715) 292-5339 (MOBILE)
EMAIL: WaterSewerSupvr@badriver-nsn.gov

XCEL ENERGY - ELECTRICITY-TRANSMISSION
MITCHELL DIENGER
414 NICOLLET MALL 5TH FLOOR
MINNEAPOLIS, MN 55401
PHONE: (612) 321-3109 (OFFICE)
PHONE: (608) 386-2233 (MOBILE)
MITCHELL.A.DIENGER@EXCELENERGY.COM

CENTURY LINK- COMMUNICATIONS LINE
RUSSELL VANCE
135 N 28TH ST
SUPERIOR, WI 54880
PHONE: (715) 919-8003
RUSSELL.VANCE@LUMEN.COM
RELOCATIONS@LUMEN.COM

XCEL ENERGY - GAS/PETROLEUM
MATT ROONI
2004 FARM RD
ASHLAND, WI 54806
PHONE: (715) 682-6927 (OFFICE)
PHONE: (715) 209-0229 (MOBILE)
MATTHEW.W.ROONI@EXCELENERGY.COM

PENINSULA FIBER NETWORK- COMMUNICATIONS LINE
JON FRENCH
204 STATE STREET
PO BOX 9
BARAGA, MI 49908
PHONE: (906) 353-6644 (OFFICE)
PHONE: (906) 370-5995 (MOBILE)
JFRENCH@UP.NET

COPY ALL XCEL ENERGY CORRESPONDENCE TO
CORISSA SEELY
1414 W HAMILTON AVENUE
PO BOX 8
EAU CLAIRE, WI 54702-0008
PHONE: (715)-737-4097
CORISSA.E.SEELY@EXCELENERGY.COM

MERIT NETWORK INC - COMMUNICATIONS LINE
DUSTIN LAPOINTE
880 TECHNOLOGY DR SUITE B
ANN ARBOR, MI 48103
PHONE (734) 476-6100
DLAPOINTE@MERIT.EDU

BAYFIELD ELECTRIC COOPERATIVE INC - ELECTRICITY
KEN KOOSMANN
68460 DISTRIC ST
PO BOX 68
IRON RIVER, WI 54847
PHONE: (715) 372-4287 (OFFICE)
PHONE: (715) 681-0000 (MOBILE)
KKOOSMANN@BAYFIELDELECTRIC.COM

BAD RIVER NATURAL RESOURCES DEPARTMENT

NATURAL RESOURCES DEPARTMENT
NAOMI TILLISON
PO BOX 39
ODANAH, WI 54861
PHONE: (715)685-7840 EXT. 1561
EMAIL: nrdirector@badriver-nsn.gov

TRIBAL HISTORIC PRESERVATION OFFICE
EDITH LEOSO
PO BOX 39
ODANAH, WI 54861
PHONE: (715)685-7840 EXT. 1662
EMAIL: THPO@badriver-nsn.gov

WISCONSIN DEPARTMENT OF NATURAL RESOURCES

WDNR - NORTHWEST DISTRICT HEADQUARTERS
SHAWN HASELEU
810 WEST MAPLE STREET
SPOONER, WI 54801
PHONE: (715)635-4228
EMAIL: Shawn.Haseleu@wisconsin.gov

GENERAL NOTES:

RESTORE SIDEROAD INTERSECTIONS AND PRIVATE ENTRANCES TO EXISTING CONDITIONS UNLESS SHOWN OTHERWISE.

THE EXACT CONSTRUCTION LIMITS OF PRIVATE ENTRANCES SHALL BE COORDINATED WITH THE ENGINEER IN THE FIELD.

WHEN THE QUANTITY OF BASE AGGREGATE IS MEASURED BY THE TON, THE THICKNESS OF THE LAYER SHOWN ON THE PLAN IS APPROXIMATE, AND THE ACTUAL THICKNESS WILL DEPEND ON THE DISTRIBUTION OF MATERIAL AS DIRECTED BY THE ENGINEER.

PRIOR TO THE PLACEMENT OF GUARDRAIL, THE SHOULDERS SHALL BE IN PLACE, SHAPED, AND COMPACTED UNLESS SHOWN OTHERWISE.

IN GUARDRAIL AREAS, EXTEND PAVED SHOULDER OUT TO GUARDRAIL FACE.

NO TREES OR SHRUBS ARE TO BE REMOVED WITHOUT APPROVAL OF THE ENGINEER.

DISTURBED AREAS WITHIN THE RIGHT-OF-WAY, EXCEPT THE AREAS WITHIN THE FINISHED SHOULDER POINTS, SHALL BE FERTILIZED, SEEDED AND COVERED WITH EROSION MAT.

THE LOCATIONS OF EXISTING AND PROPOSED UTILITY FACILITIES AS SHOWN ON THE PLAN ARE APPROXIMATE. THERE MAY BE OTHER UTILITY FACILITIES WITHIN THE PROJECT AREA THAT ARE NOT SHOWN.

EXISTING SURVEY MONUMENTS SHALL NOT BE DAMAGED OR REMOVED

ALL OPERATIONS REQUIRE A TRIBAL ENTRY PERMIT AVAILABLE ON THE BAD RIVER WEB SITE: <https://www.badriver-nsn.gov/natural-resources/projectreviews/>



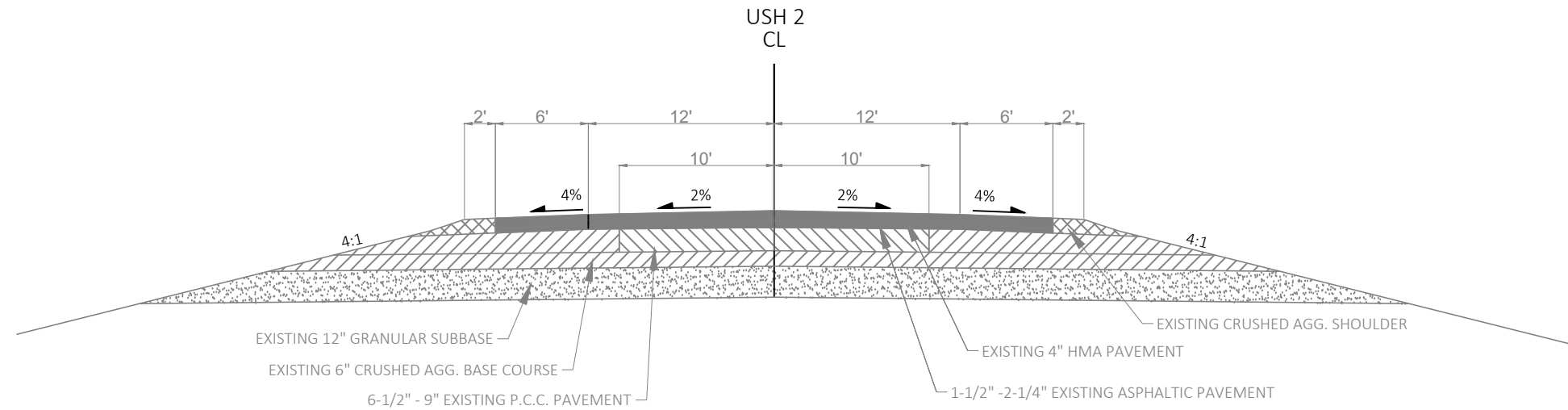

TYPICAL EXISTING SECTION
STA 441+89 TO 471+33

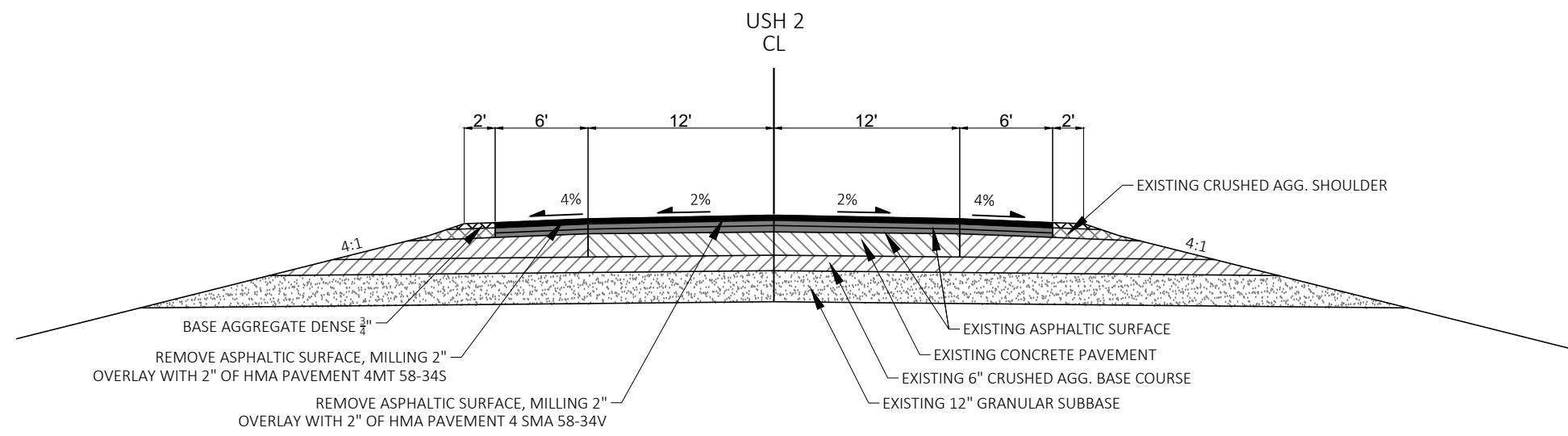

TYPICAL FINISHED SECTION
STA 441+89 TO 471+33

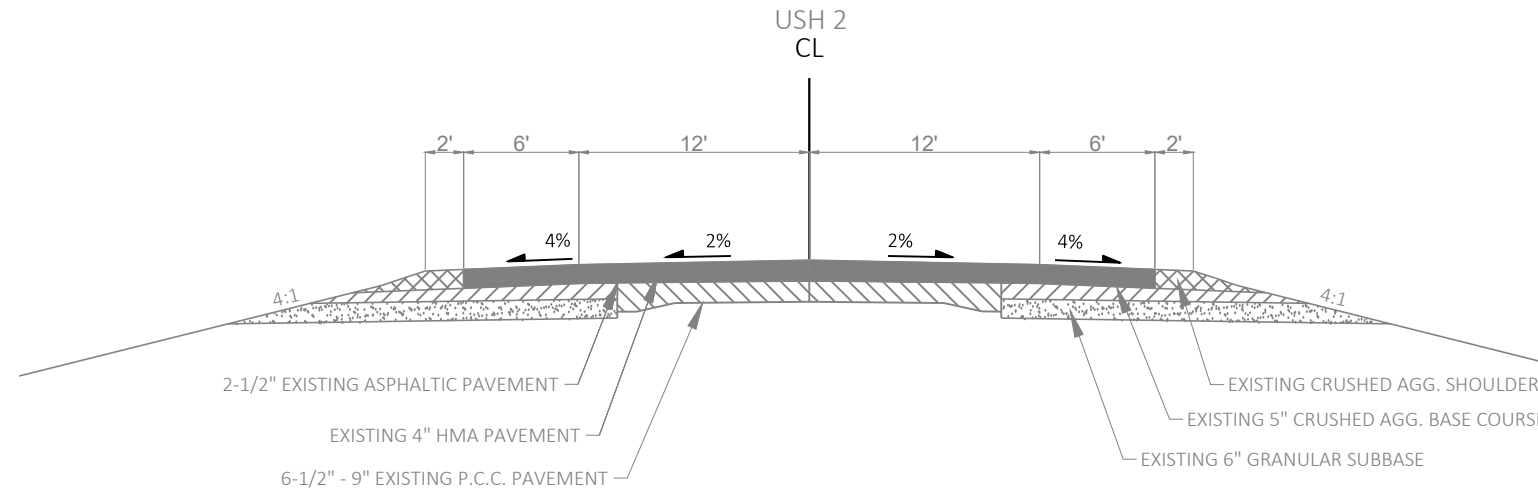

TYPICAL EXISTING SECTION

STA 471+33 TO 513+88
STA 519+59 TO 550+83

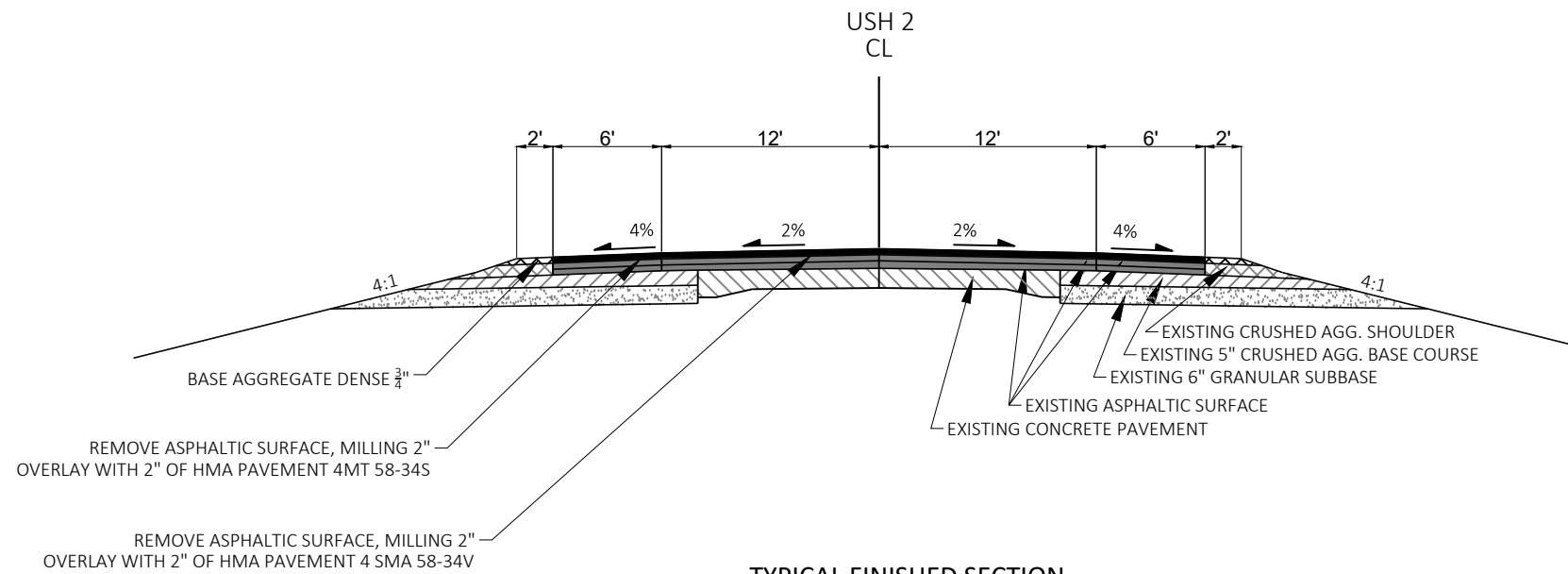

TYPICAL FINISHED SECTION

STA 471+33 TO 513+88
STA 519+59 TO 542+10

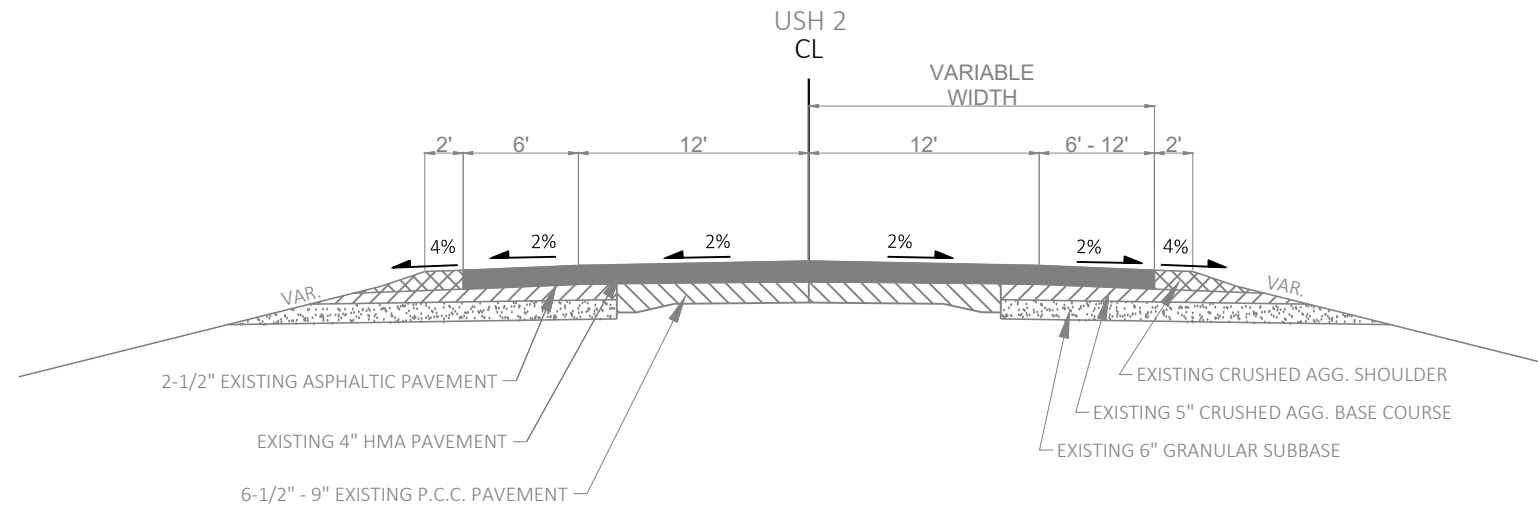

TYPICAL EXISTING SECTION

STA 513+88 TO 519+59

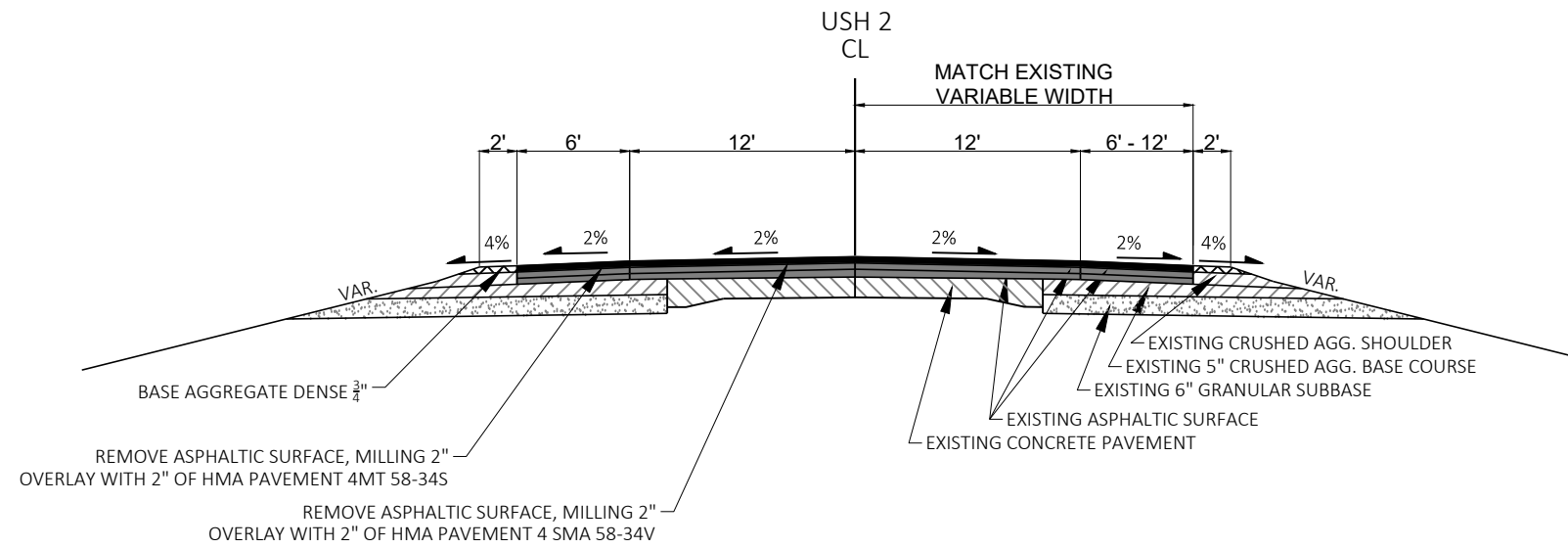

TYPICAL FINISHED SECTION

STA 513+88 TO 519+59

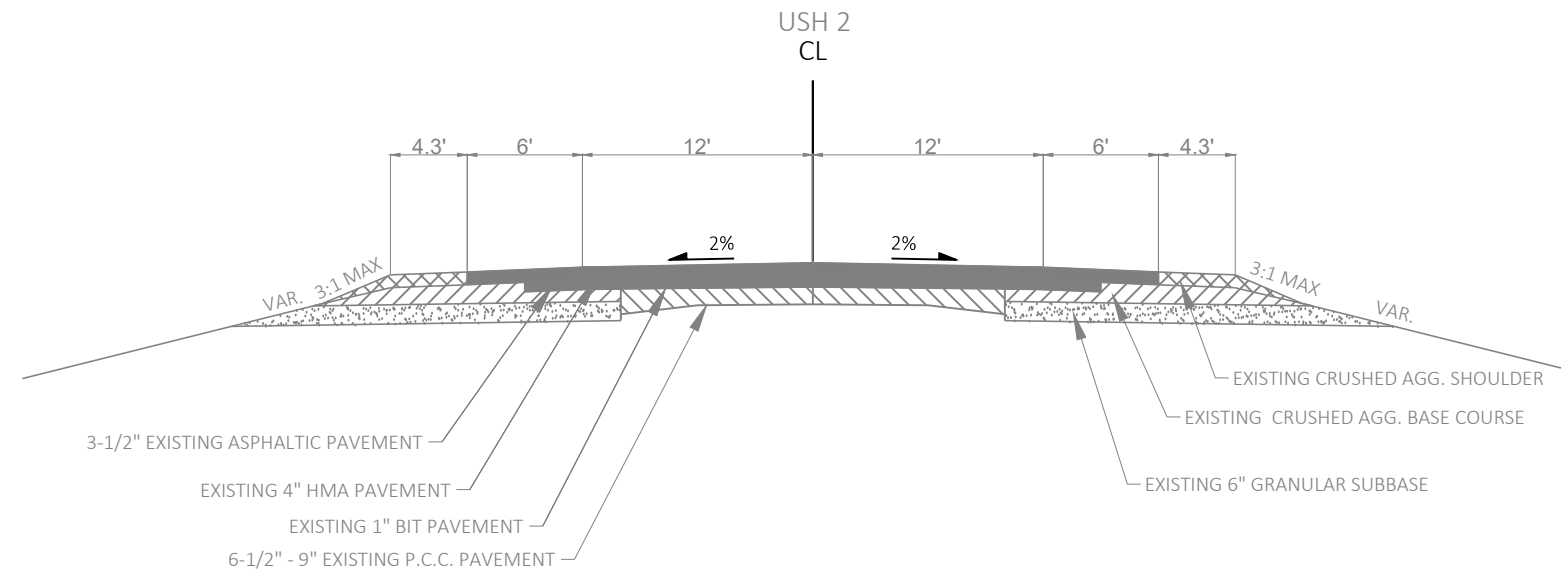

TYPICAL EXISTING SECTION

STA 571+91 TO 602+00
STA 617+00 TO 743+16
STA 749+63 TO 762+97

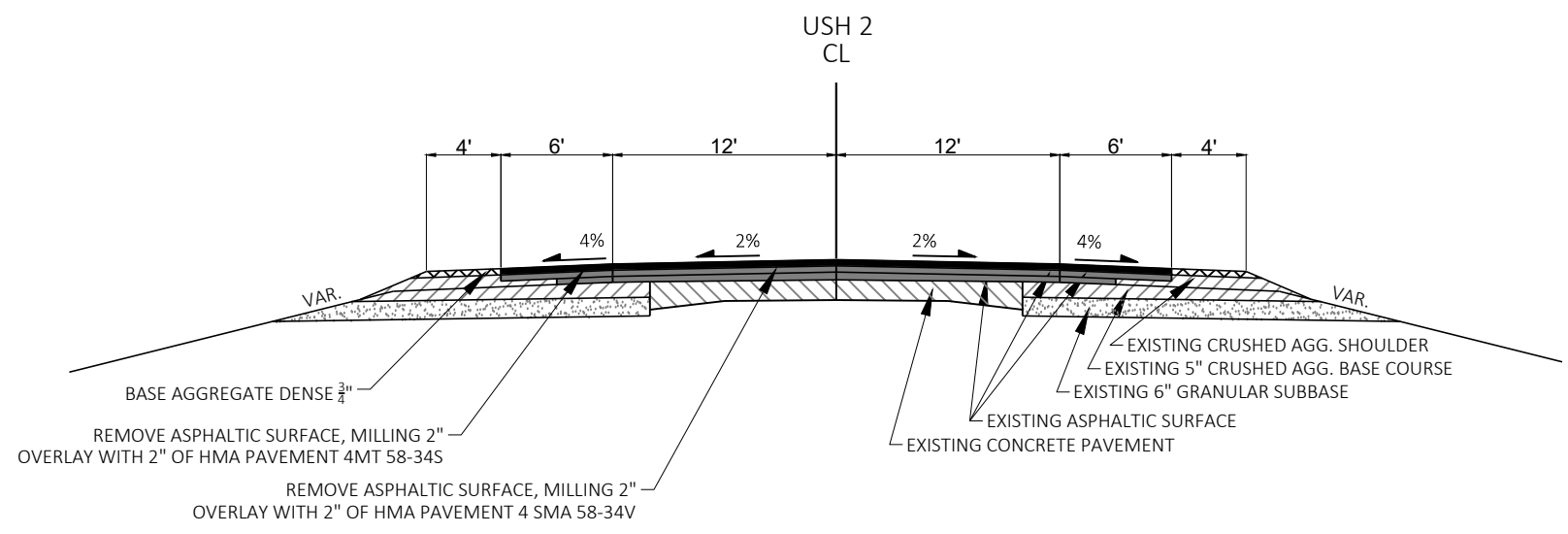

TYPICAL FINISHED SECTION

STA 574+95 TO 602+00
STA 617+00 TO 743+16
STA 749+63 TO 762+97

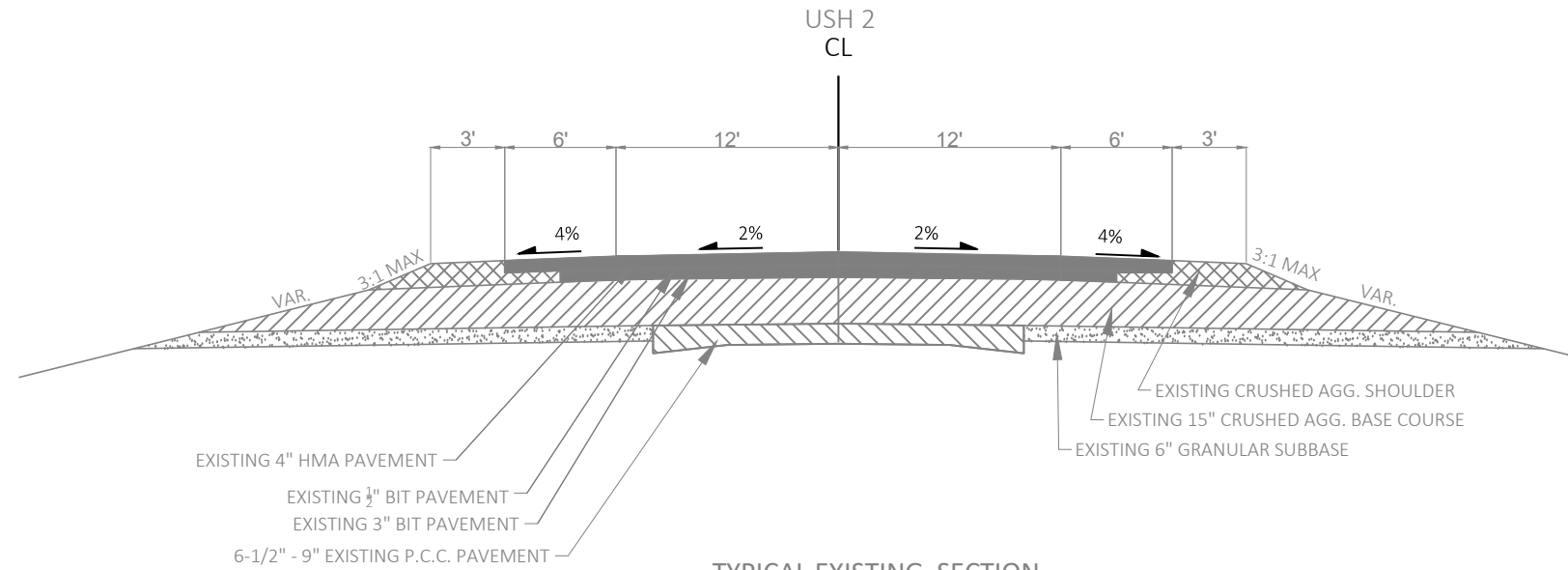

STA 602+00 TO 605+12
STA 614+68 TO 617+00

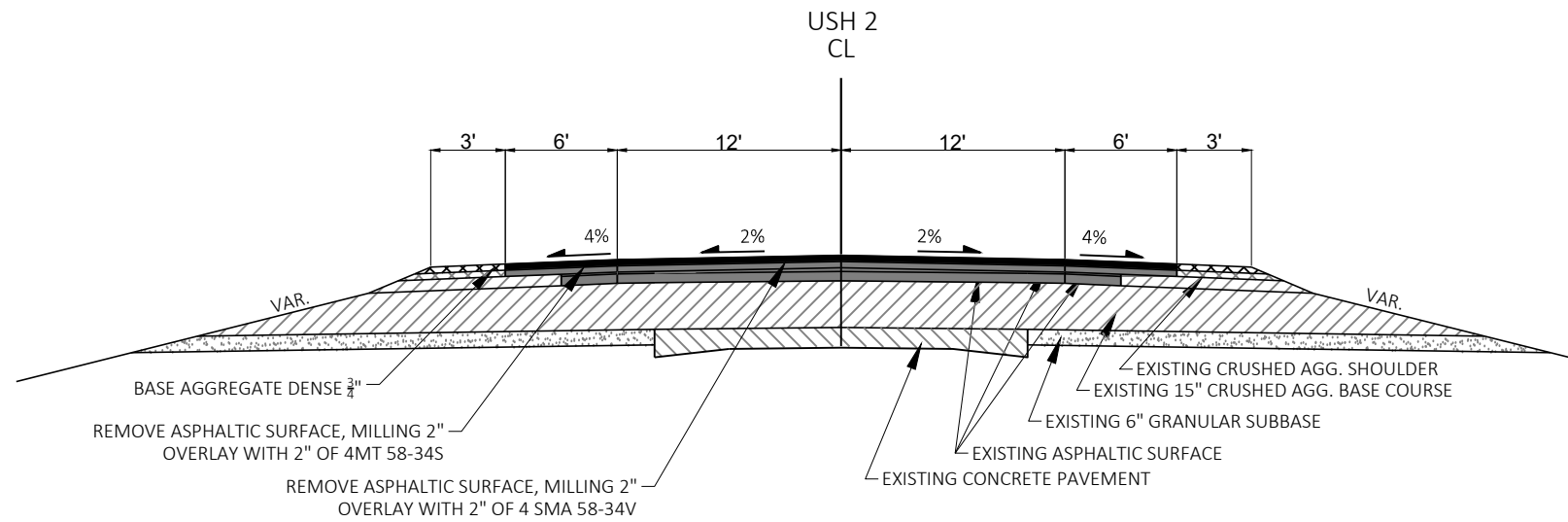

TYPICAL FINISHED SECTION

STA 602+00 TO 605+12
STA 614+68 TO 617+00

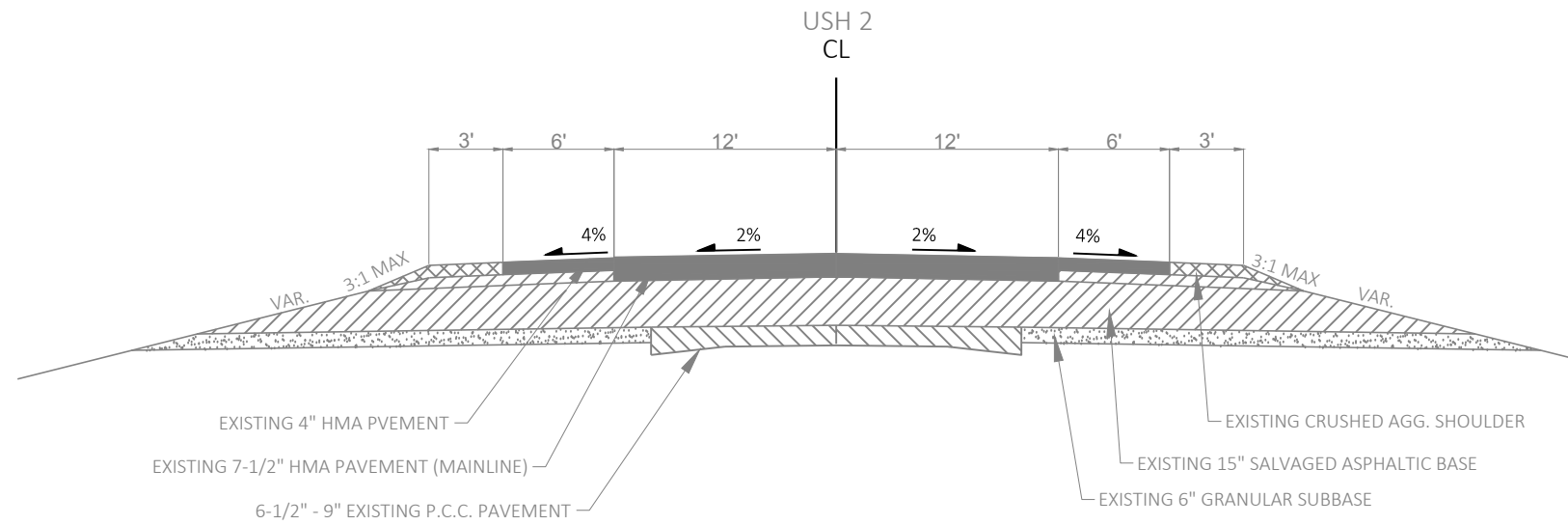

TYPICAL EXISTING SECTION

STA 605+12 TO 614+68

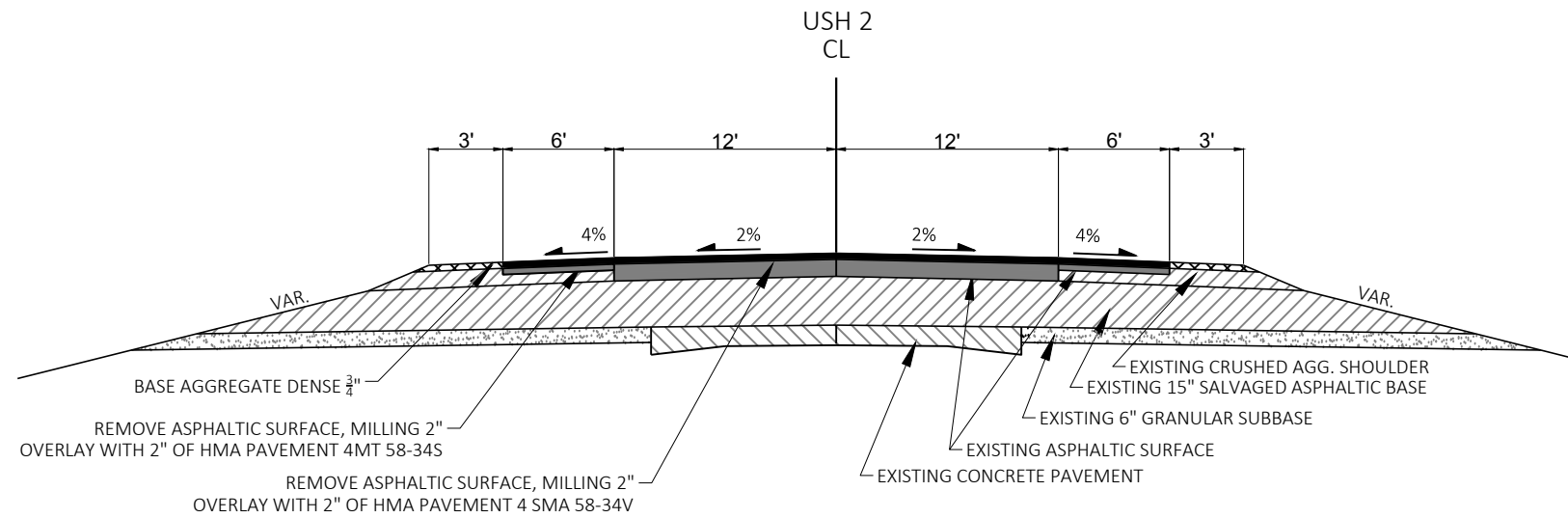

TYPICAL FINISHED SECTION

STA 605+12 TO 614+68

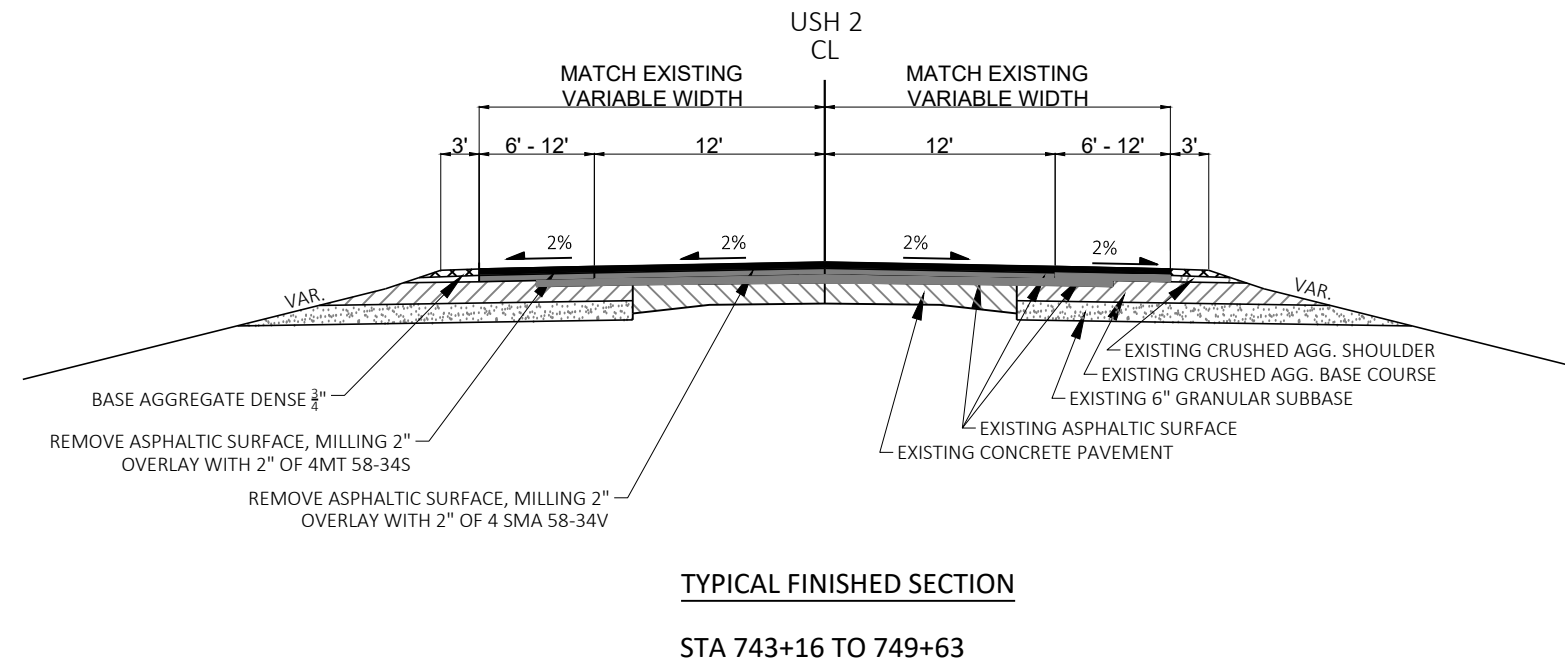
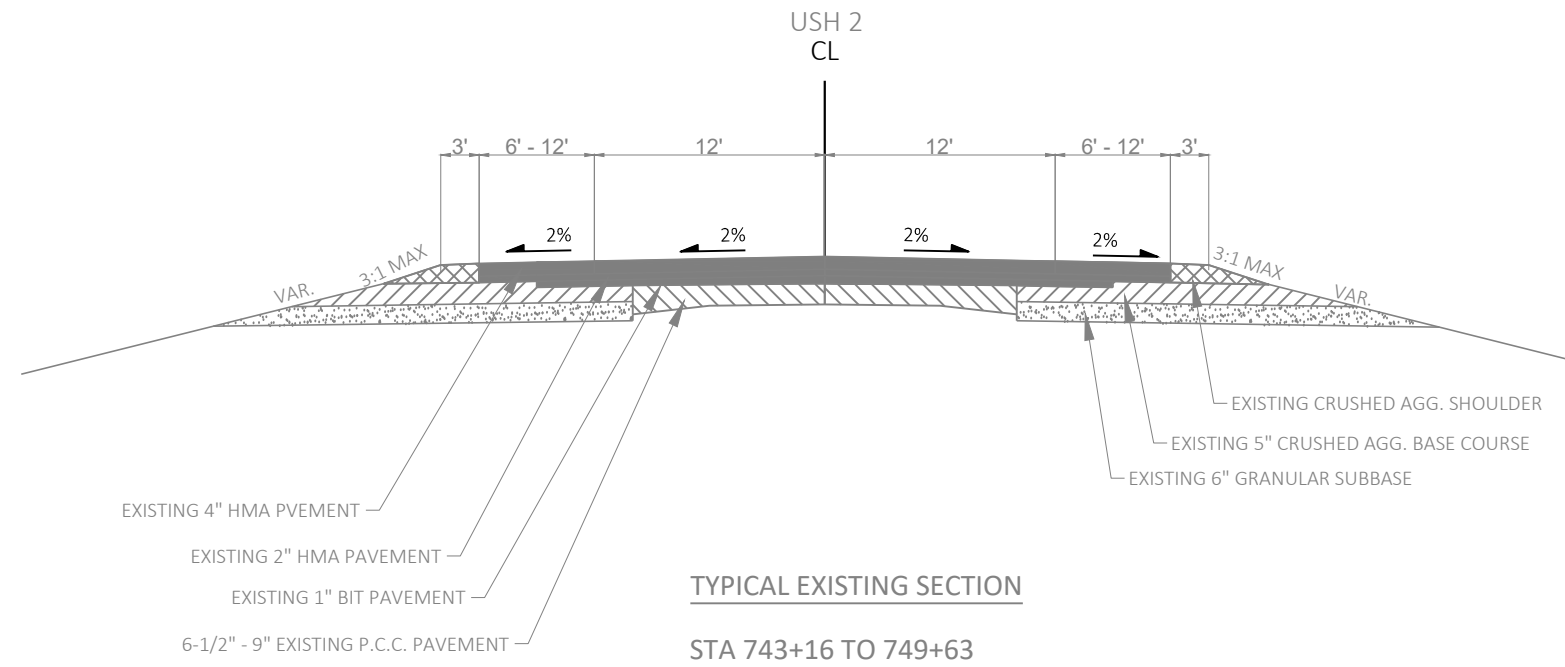

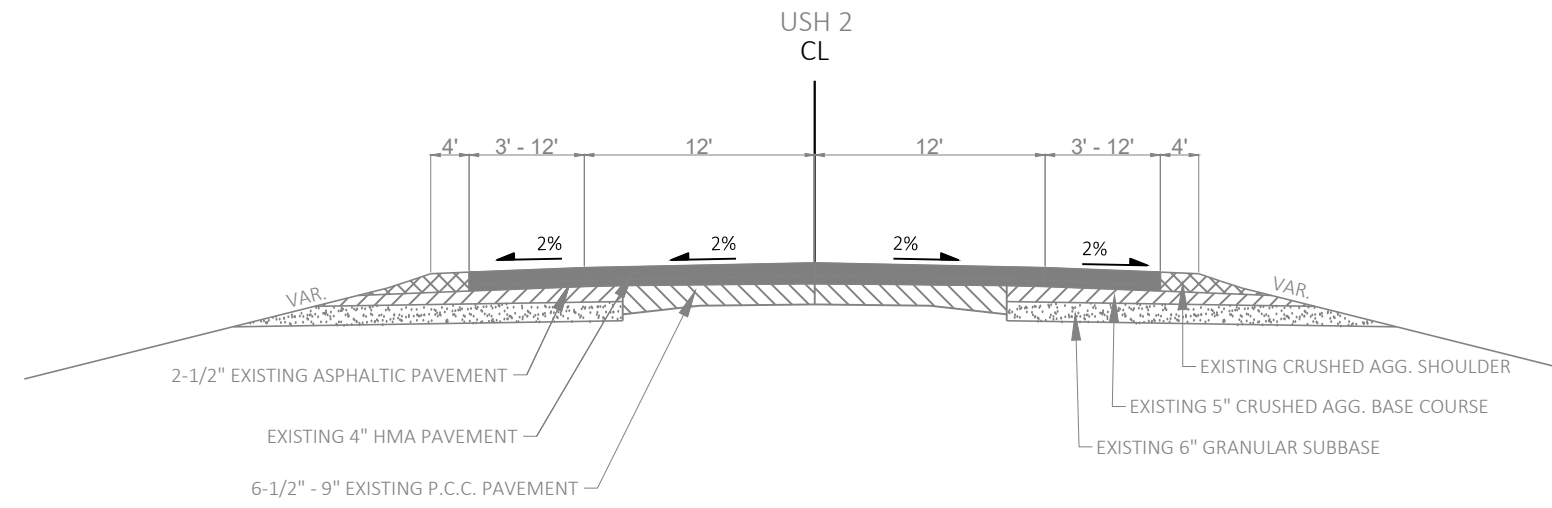

TYPICAL EXISTING SECTION
 STA 762+97 TO 773+60

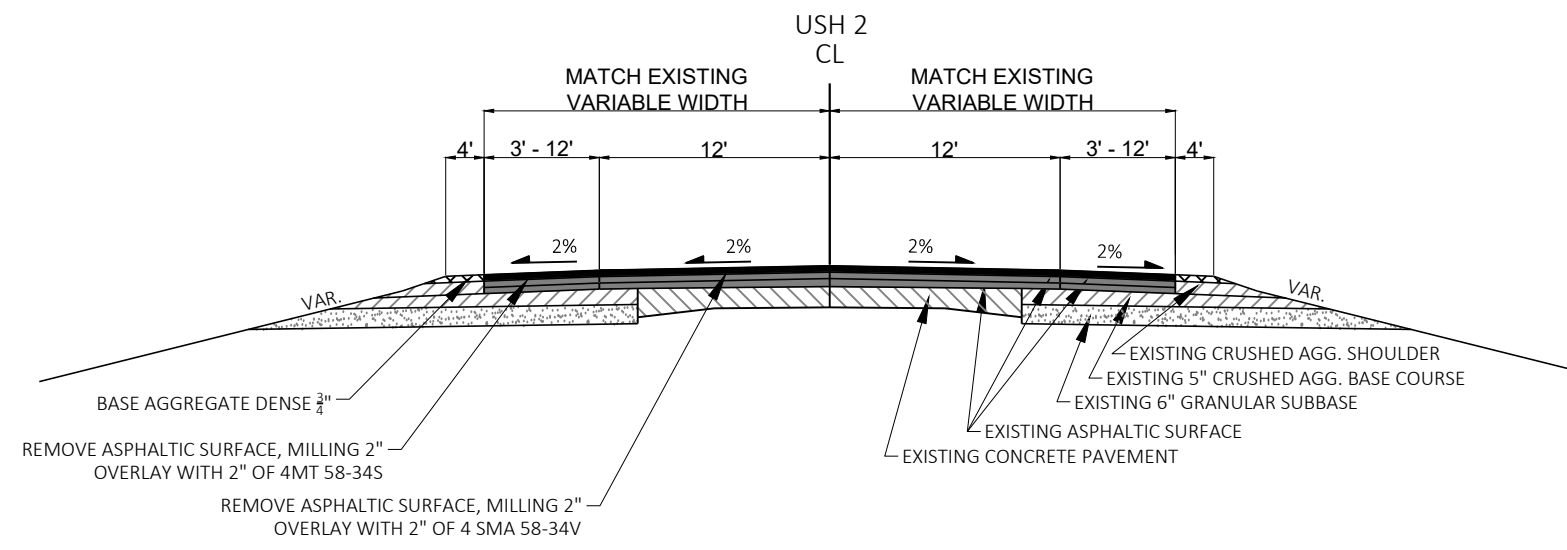

TYPICAL FINISHED SECTION
 STA 762+97 TO 773+60

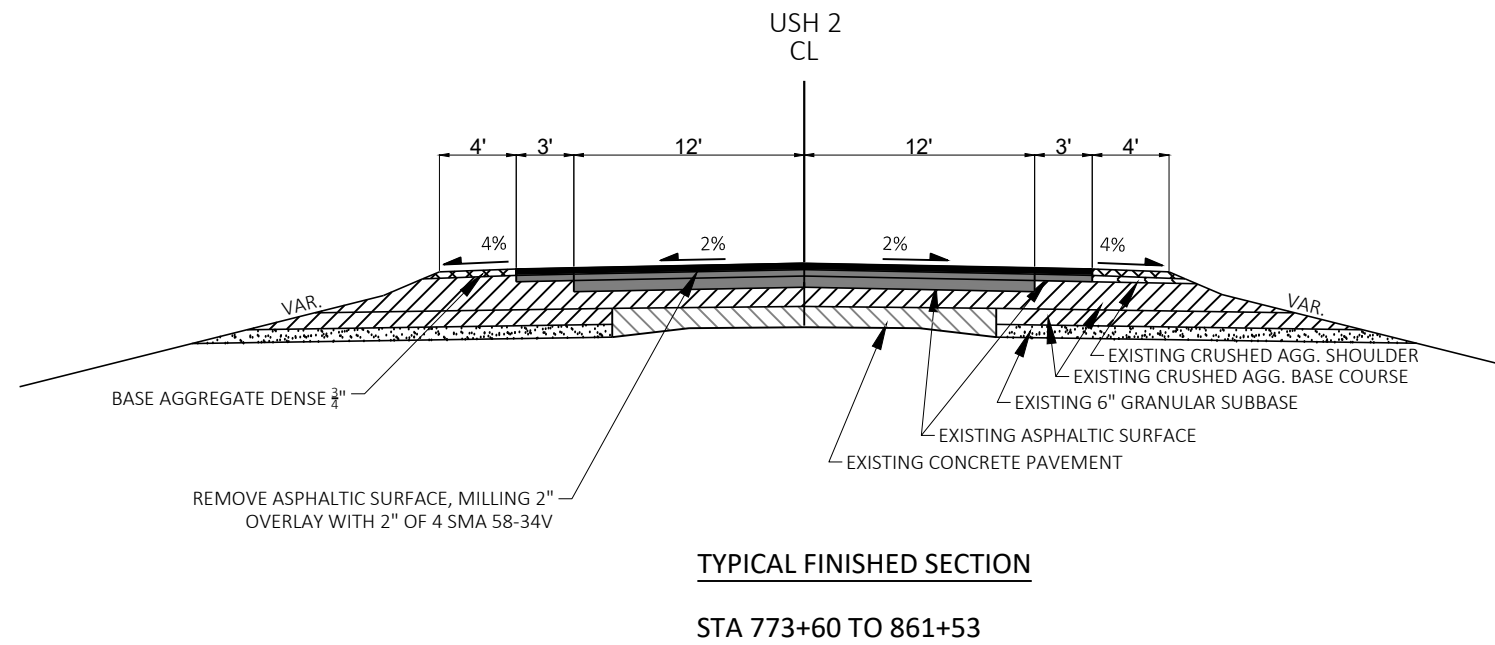
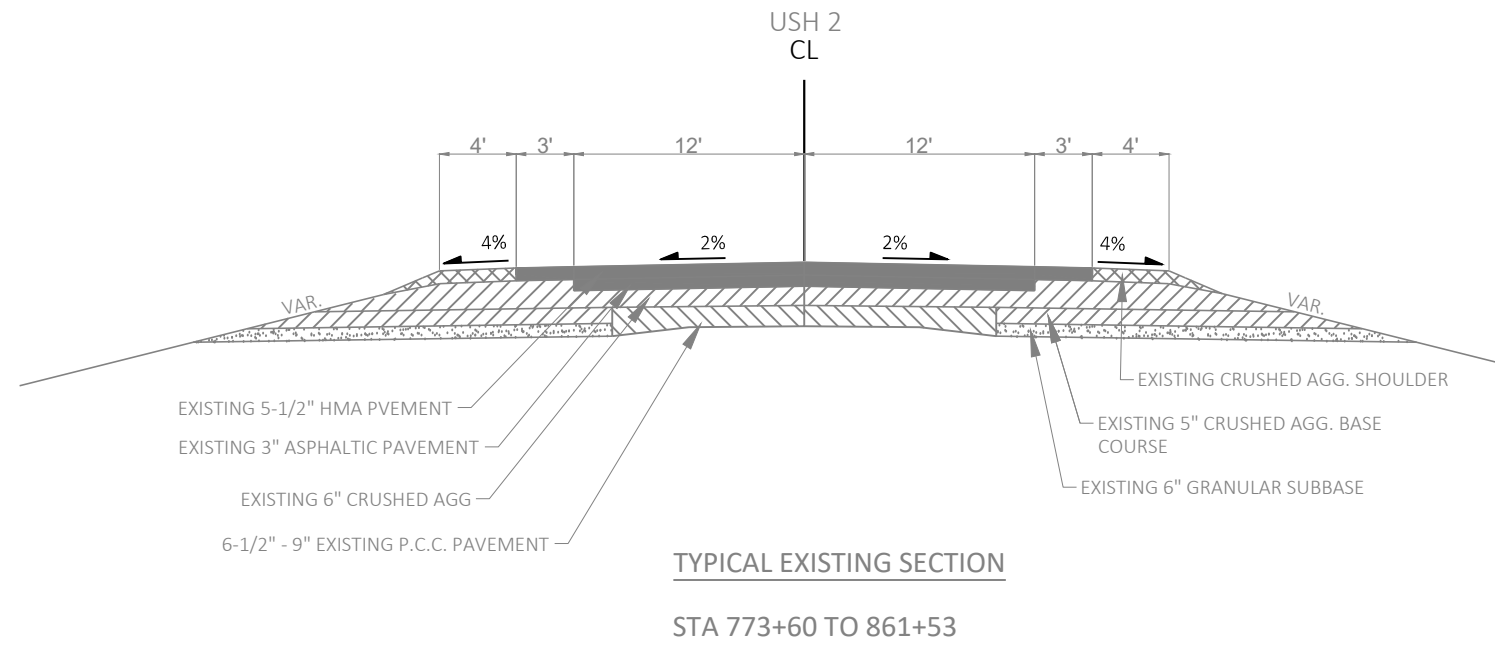

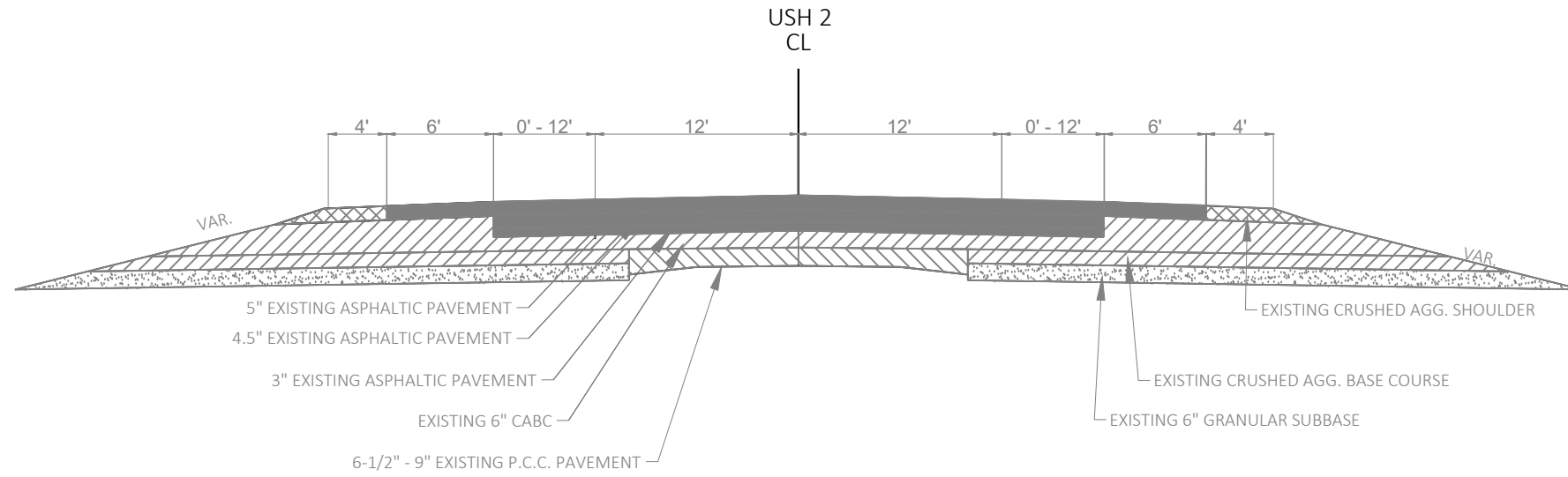

TYPICAL EXISTING SECTION

STA 861+53 TO 924+70

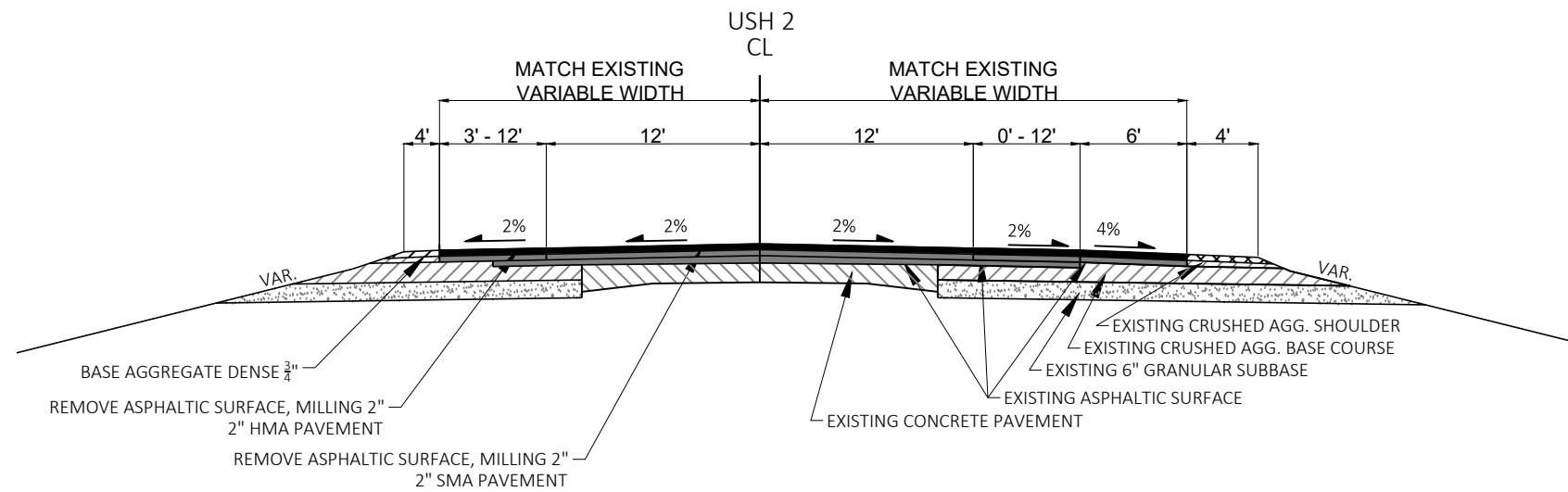

TYPICAL FINISHED SECTION

STA 861+53 TO 924+70

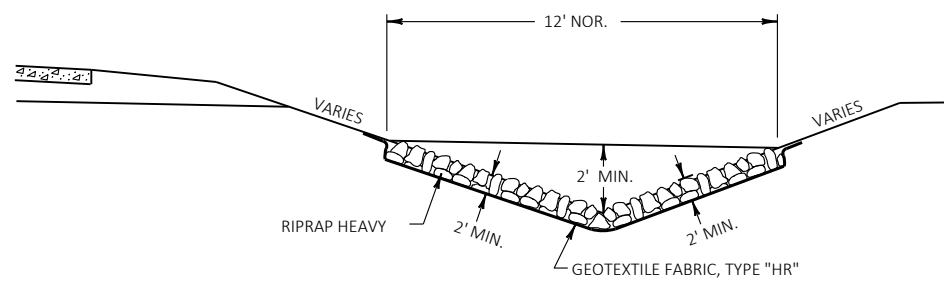
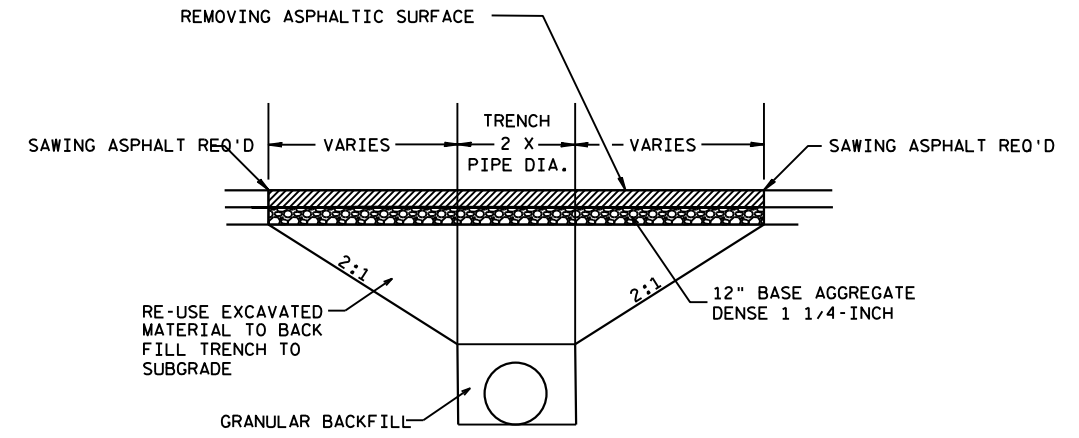

DETAIL OF RIPRAP HEAVY DITCH

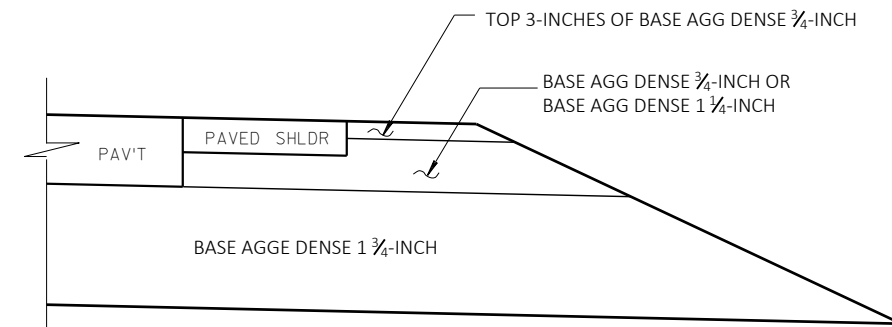

BASE AGG DENSE 1 1/4-INCH REQUIRED

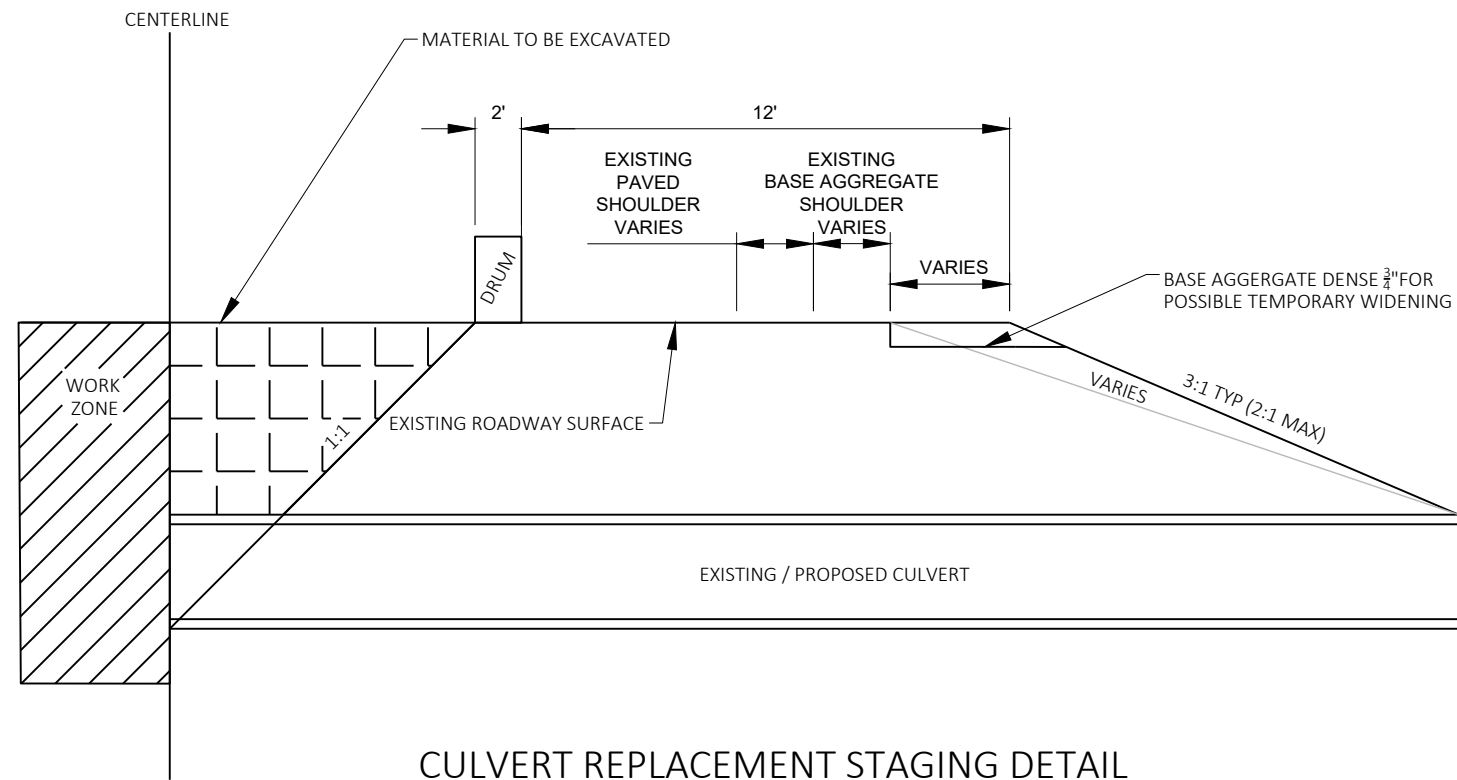

CULVERT REPLACEMENT STAGING DETAIL

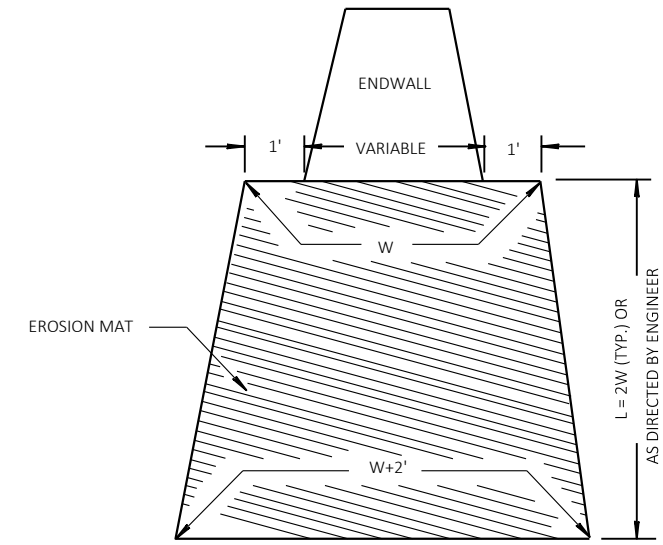

EROSION MAT TREATMENT AT CULVERTS

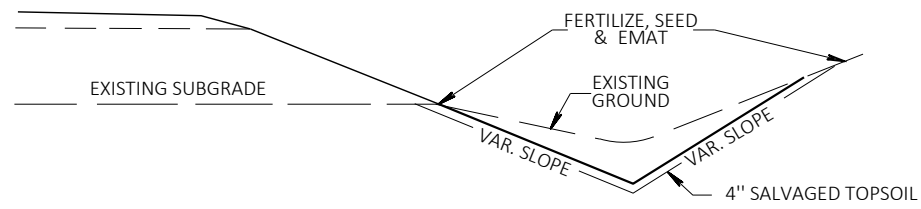

DITCH SHAPING DETAIL

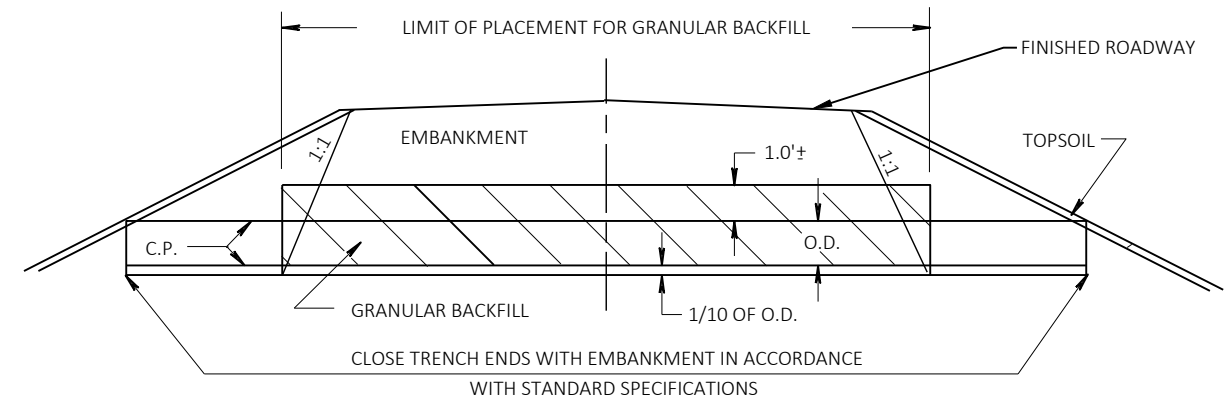

CULVERT BACKFILL DETAIL

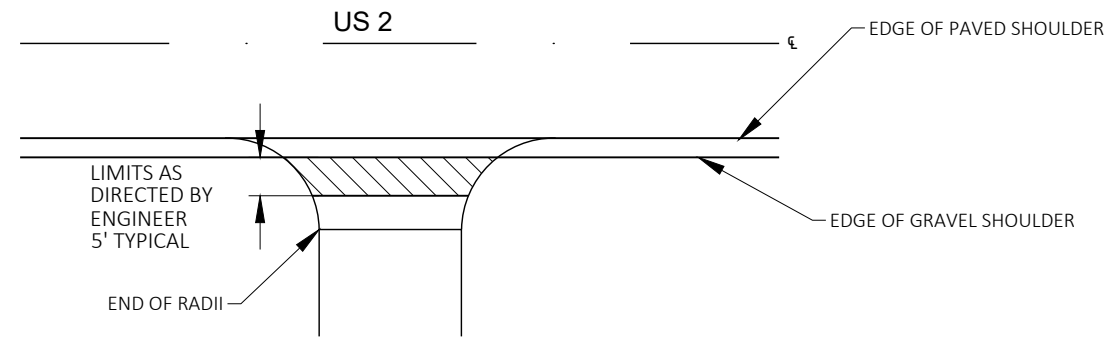

MATCH EXISTING DRIVEWAY WIDTH AND RADII
 3/4-INCH BASE AGGREGATE DENSE WILL BE USED TO BRING ENTRANCE UP TO SHOULDER PAVEMENT GRADE

RURAL DRIVEWAY DETAIL - AGGREGATE

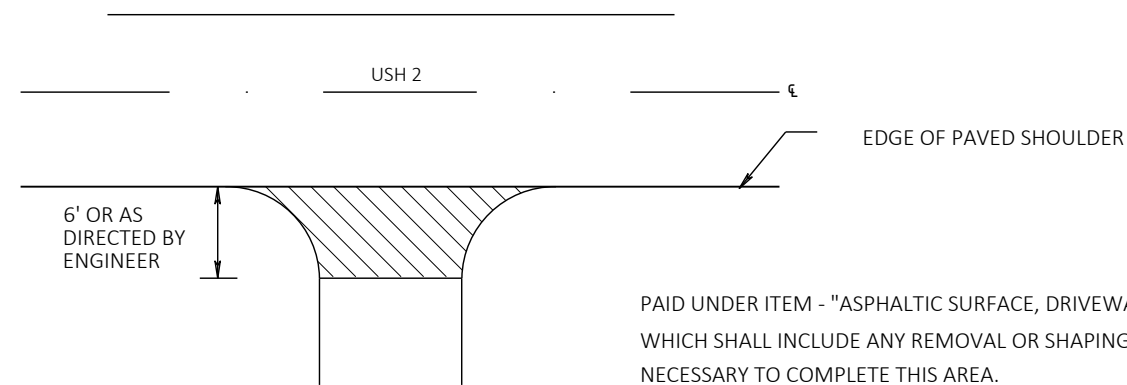

PAID UNDER ITEM - "ASPHALTIC SURFACE, DRIVEWAYS" WHICH SHALL INCLUDE ANY REMOVAL OR SHAPING NECESSARY TO COMPLETE THIS AREA.
 MATCH EXISTING PAVED SURFACE WIDTH, RADII AND TAPERS
 ANY ADDITIONAL BASE AGG. DENSE REQ'D. SHALL BE PAID UNDER ITEM - "BASE AGGREGATE DENSE 1 1/4-INCH"

RURAL DRIVEWAY DETAIL - ASPHALT

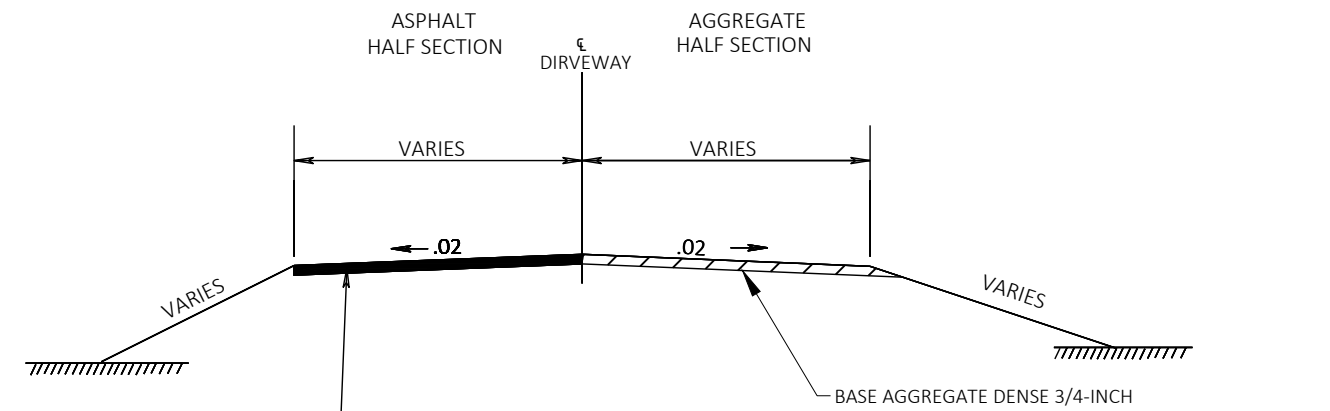

TYPICAL SECTION RURAL DRIVEWAY DETAIL

NOTE:
 DRIVEWAY PROFILES NOT EXPECTED TO EXCEED 10%. PLACE LOW POINT OF DRIVEWAY PROFILE OVER DITCH FLOW LINE.

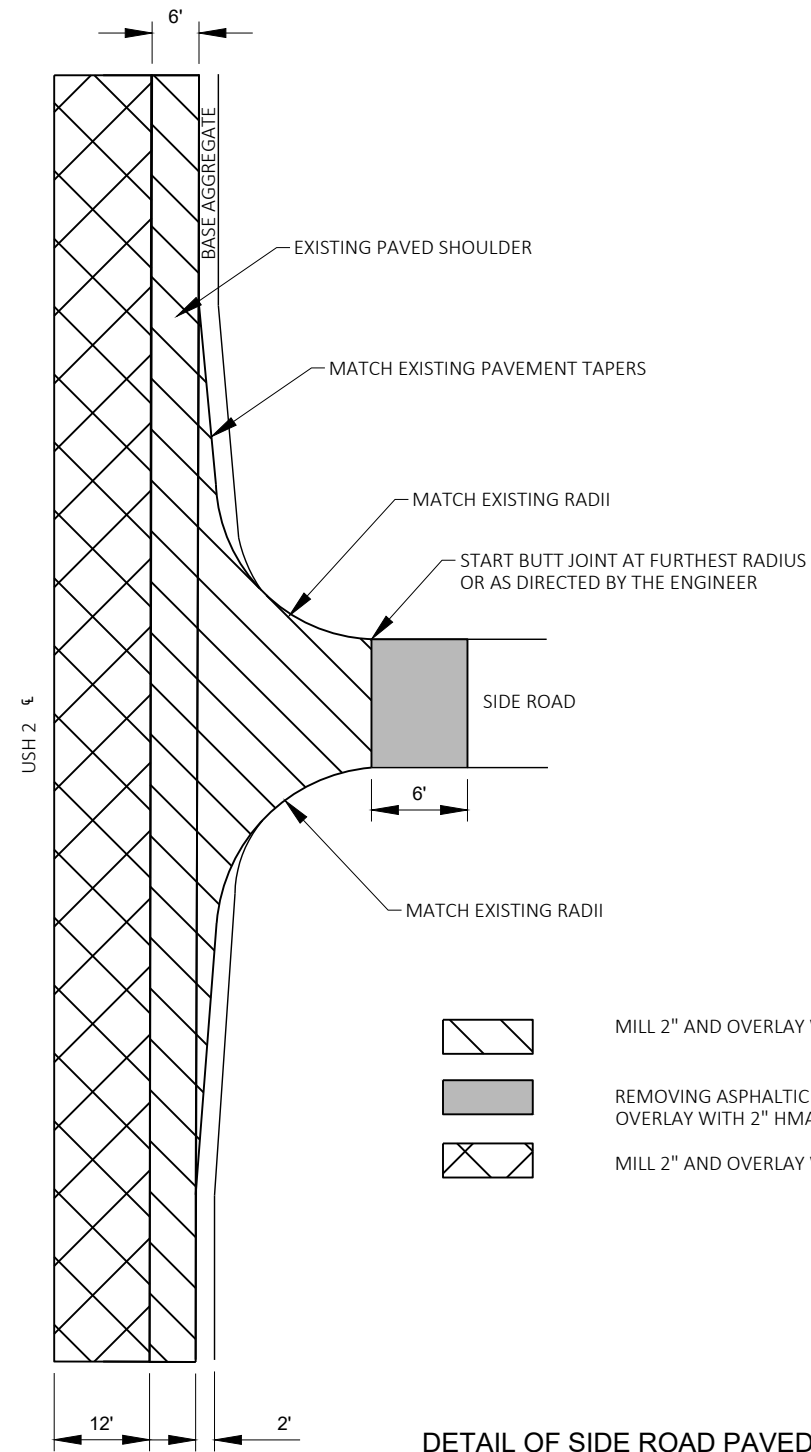

DETAIL OF SIDE ROAD PAVED

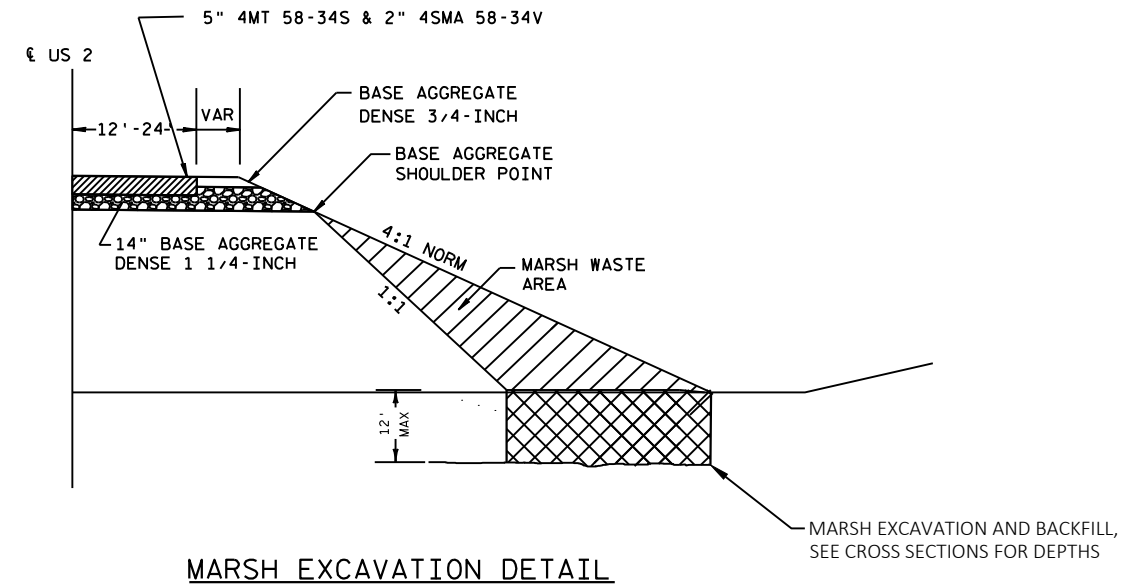

MARSH EXCAVATION DETAIL

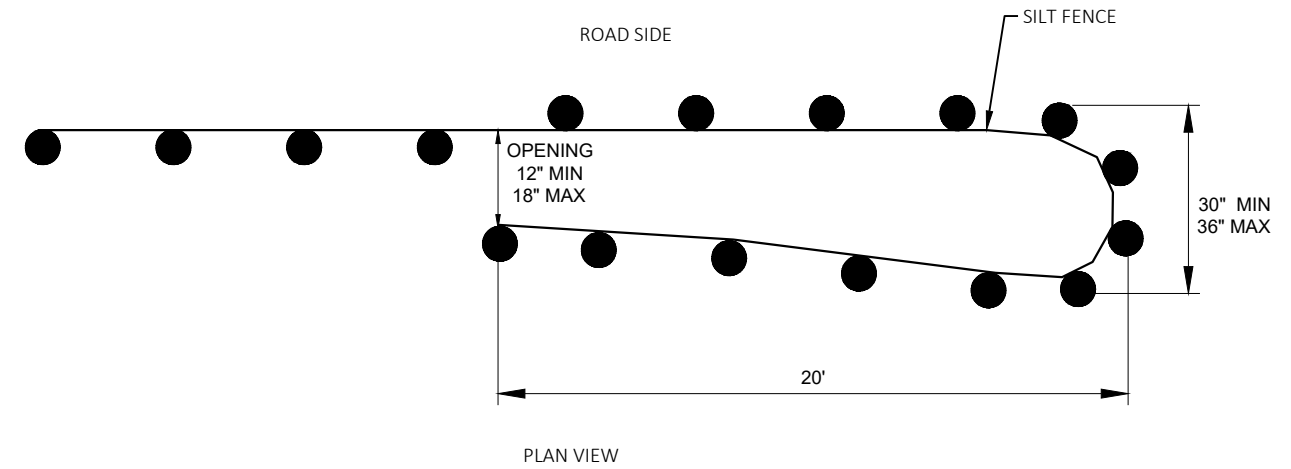



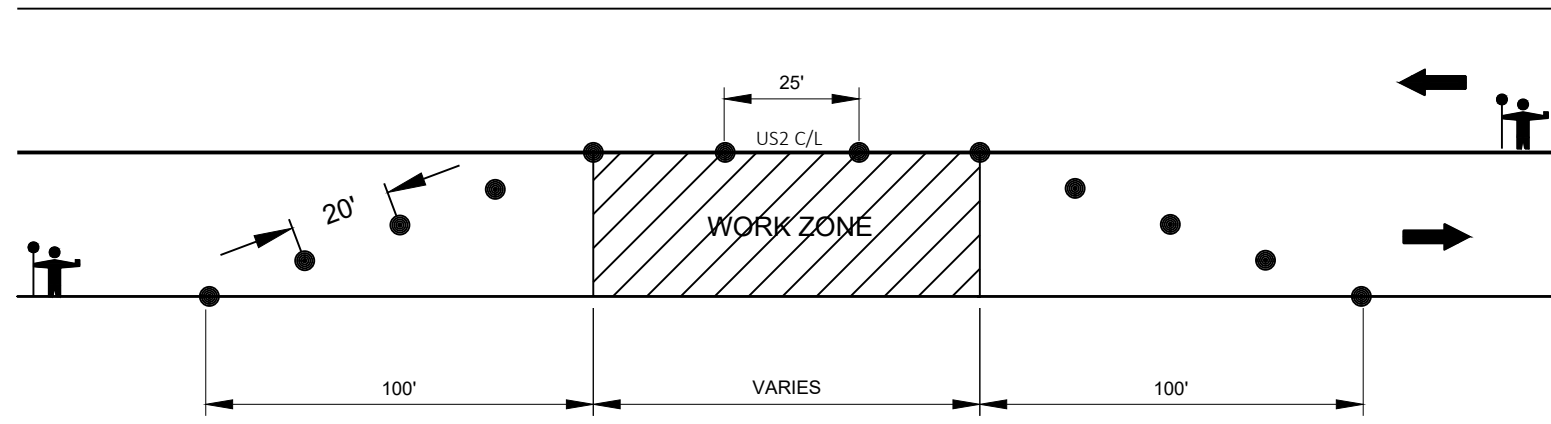

NOTE:
 SILT FENCE POST FOR THE TURN-AROUND SHOULD BE ON THE
 OUTSIDE OF THE TURN-AROUND AND THE FABRIC SHALL BE TRENCHED
 IN ACCORDING TO SILT FENCE REQUIREMENTS.
 PAID FOR AS SILT FENCE

TEMPORARY SMALL ANIMAL TURN-AROUND DETAIL

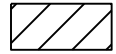

NOTE: SDD 15C12 "TRAFFIC CONTROL FOR LANE CLOSURE WITH FLAGGING OPERATION SHALL BE USED WITH THIS DETAIL AT CULVERT REPLACEMENT LOCATIONS.

LEGEND

-  WORK ZONE
-  DRUM
-  FLAGGER
-  DIRECTION OF TRAVEL

TRAFFIC CONTROL FOR CULVERT REPLACEMENT & LANE RECONFIGURATION

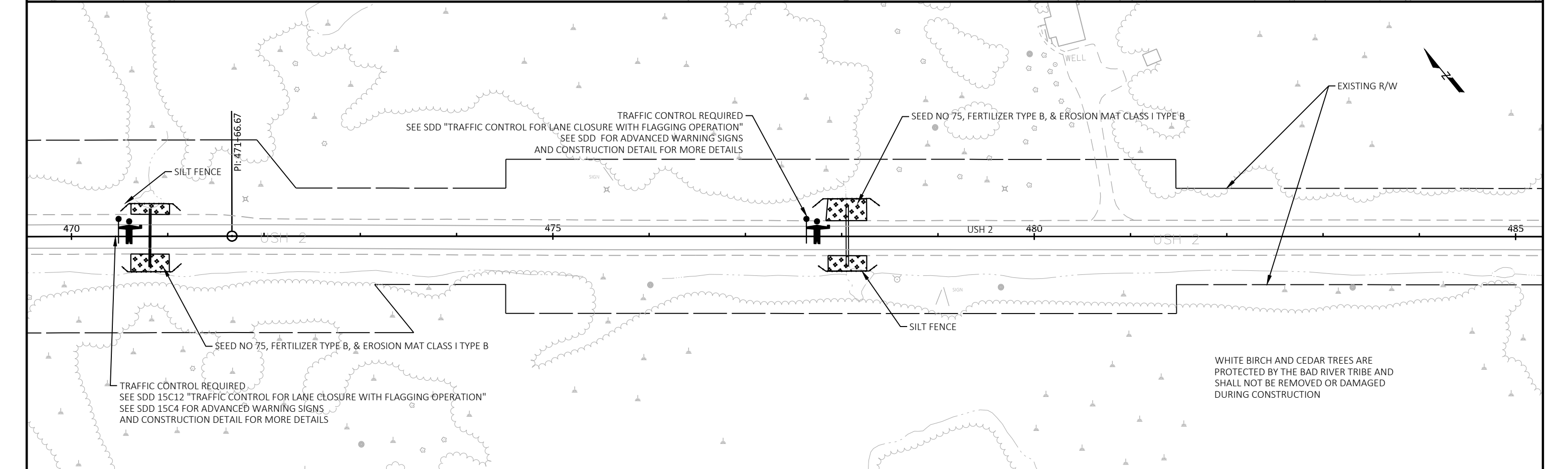
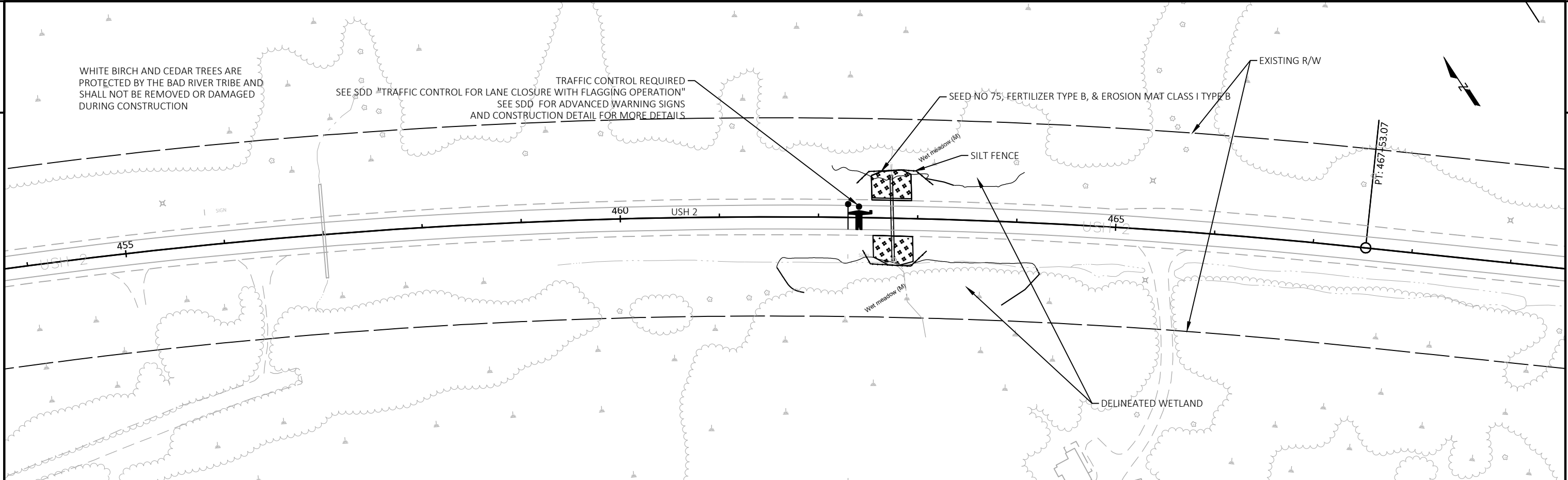

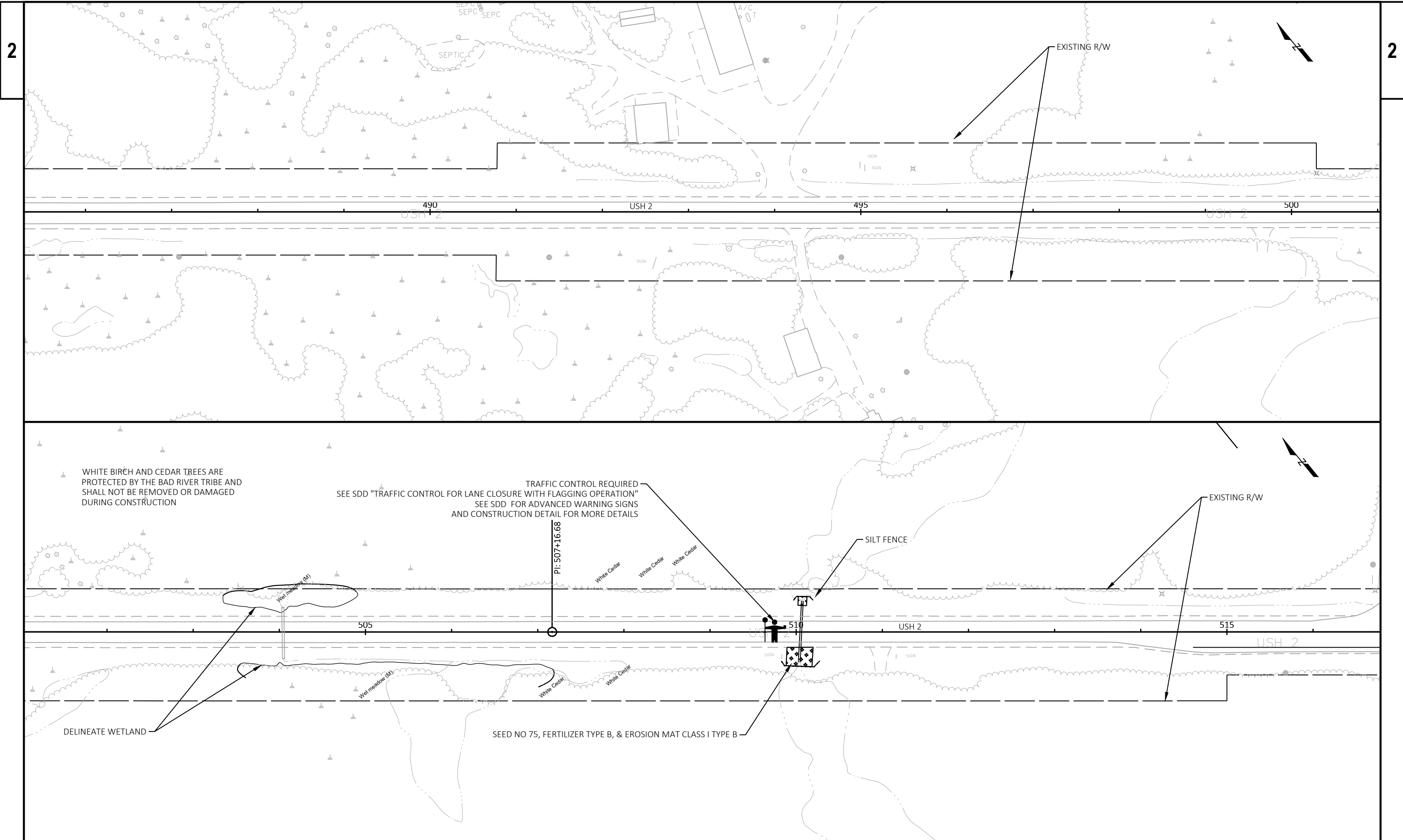

PROJECT NO: 1180-44-70	HWY: USH 2	COUNTY: ASHLAND & IRON	EROSION CONTROL & TRAFFIC CONTROL	SHEET	E
------------------------	------------	------------------------	-----------------------------------	-------	----------

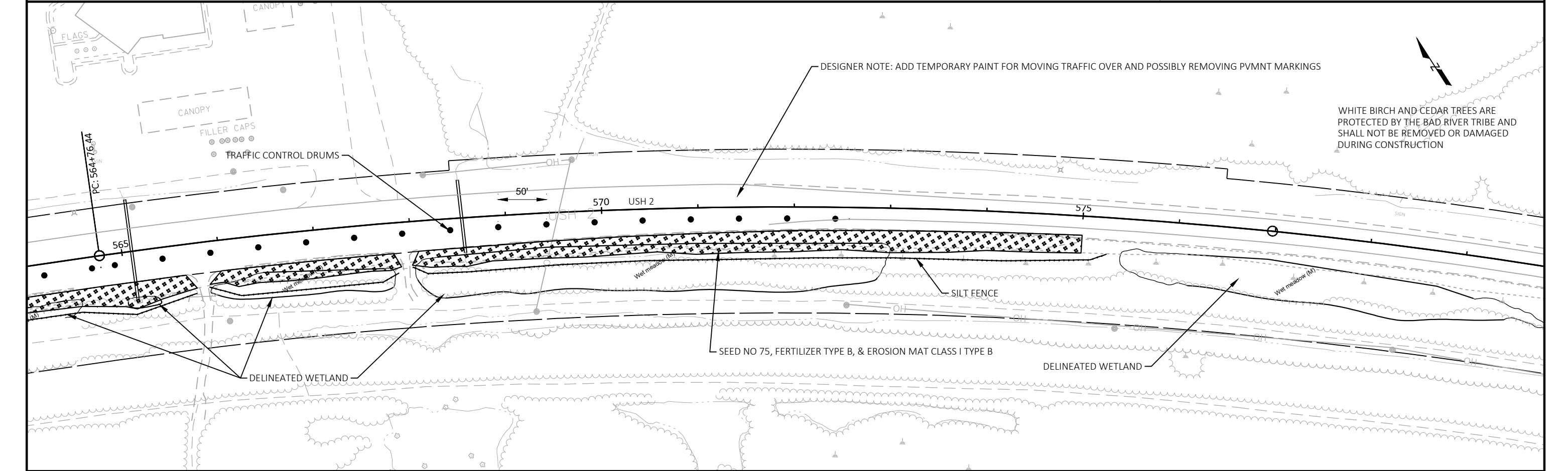
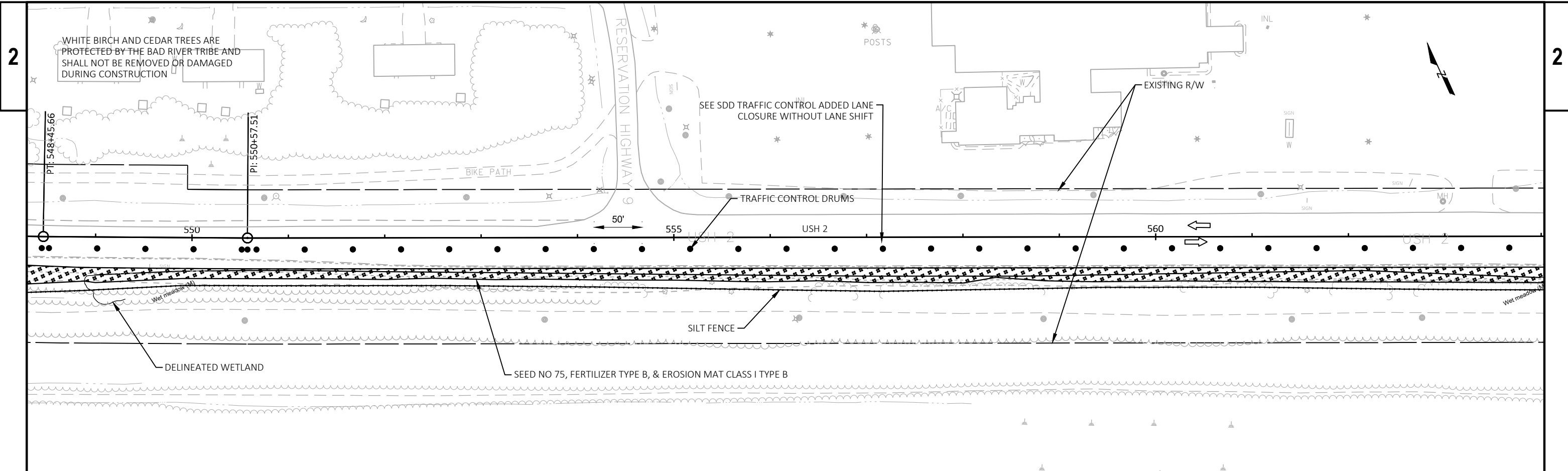

PROJECT NO: 1180-44-70	HWY: USH 2	COUNTY: ASHLAND & IRON	EROSION CONTROL & TRAFFIC CONTROL	SHEET	E
------------------------	------------	------------------------	-----------------------------------	-------	----------

TRAFFIC CONTROL REQUIRED
 SEE SDD "TRAFFIC CONTROL FOR LANE CLOSURE WITH FLAGGING OPERATION"
 SEE SDD FOR ADVANCED WARNING SIGNS
 AND CONSTRUCTION DETAIL FOR MORE DETAILS

SEED NO 75, FERTILIZER TYPE B, & EROSION MAT CLASS I TYPE B

SILT FENCE

EXISTING R/W

WHITE BIRCH AND CEDAR TREES ARE
 PROTECTED BY THE BAD RIVER TRIBE AND
 SHALL NOT BE REMOVED OR DAMAGED
 DURING CONSTRUCTION

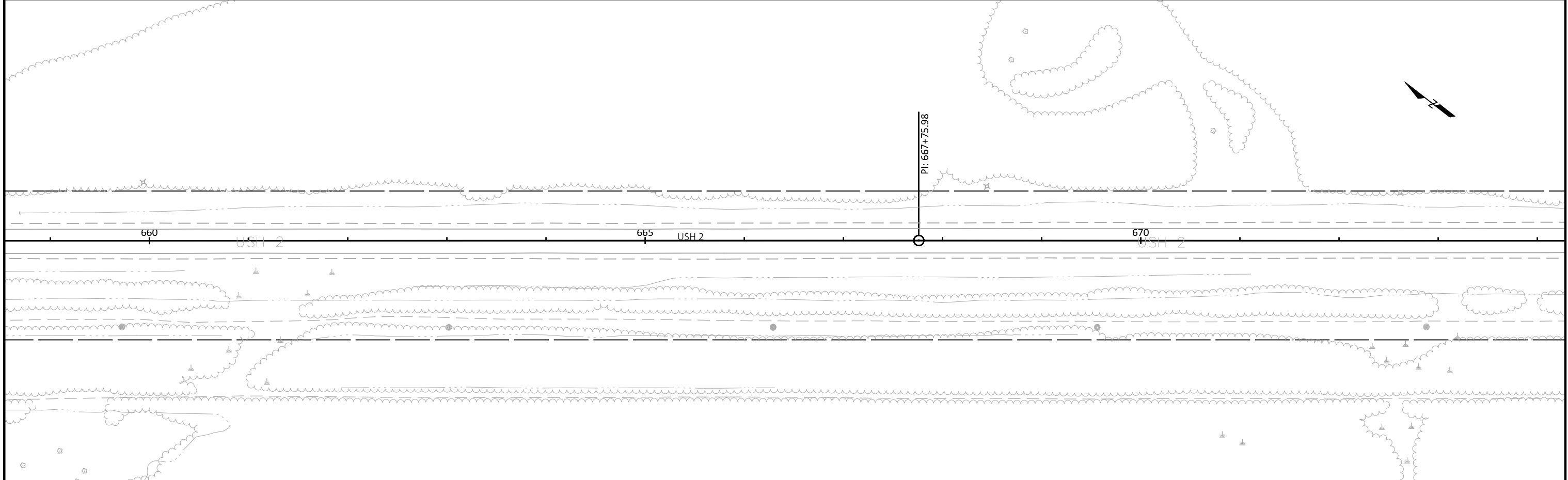
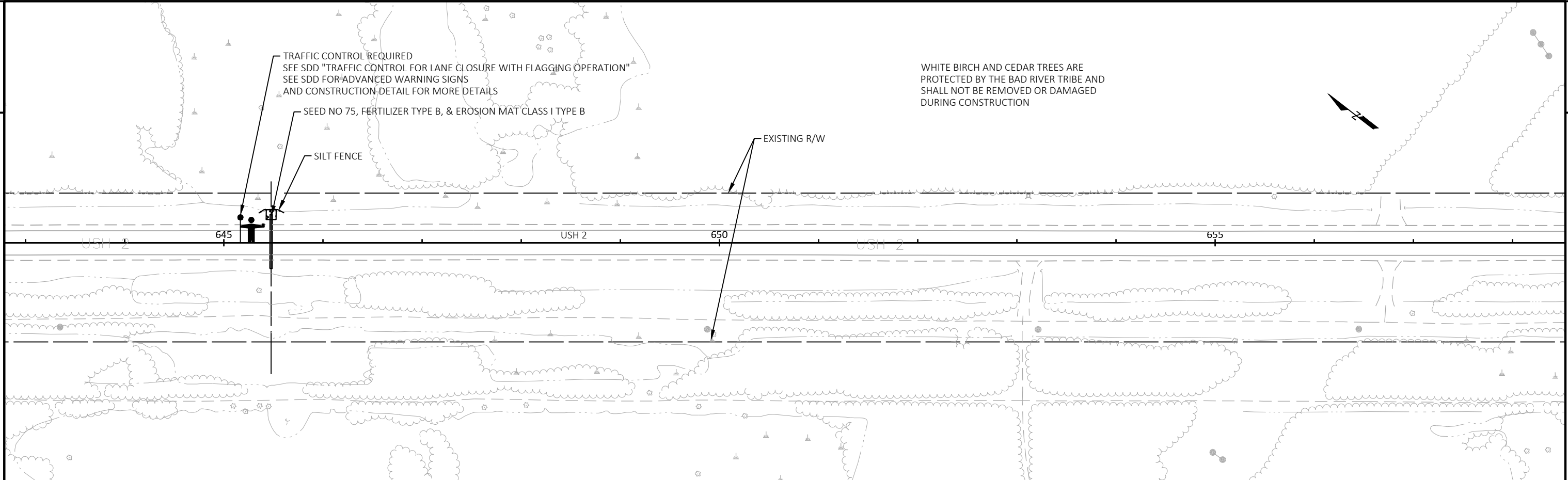

PROJECT NO: 1180-44-70	HWY: USH 2	COUNTY: ASHLAND & IRON	EROSION CONTROL & TRAFFIC CONTROL	SHEET	E
------------------------	------------	------------------------	-----------------------------------	-------	----------

WHITE BIRCH AND CEDAR TREES ARE PROTECTED BY THE BAD RIVER TRIBE AND SHALL NOT BE REMOVED OR DAMAGED DURING CONSTRUCTION

TRAFFIC CONTROL REQUIRED
SEE SDD 15C12 "TRAFFIC CONTROL FOR LANE CLOSURE WITH FLAGGING OPERATION"
SEE SDD 15C4 FOR ADVANCED WARNING SIGNS AND CONSTRUCTION DETAIL FOR MORE DETAILS

EXISTING R/W

DELINEATED WETLAND

675

680

USH 2

685

69

SILT FENCE

SEED NO 75, FERTILIZER TYPE B, & EROSION MAT CLASS I TYPE B

PI: 695+07.11

695

USH 2

USH 2

700

705

TRAFFIC CONTROL REQUIRED
SEE SDD "TRAFFIC CONTROL FOR LANE CLOSURE WITH FLAGGING OPERATION"
SEE SDD FOR ADVANCED WARNING SIGNS
AND CONSTRUCTION DETAIL FOR MORE DETAILS

WHITE BIRCH AND CEDAR TREES ARE
PROTECTED BY THE BAD RIVER TRIBE AND
SHALL NOT BE REMOVED OR DAMAGED
DURING CONSTRUCTION

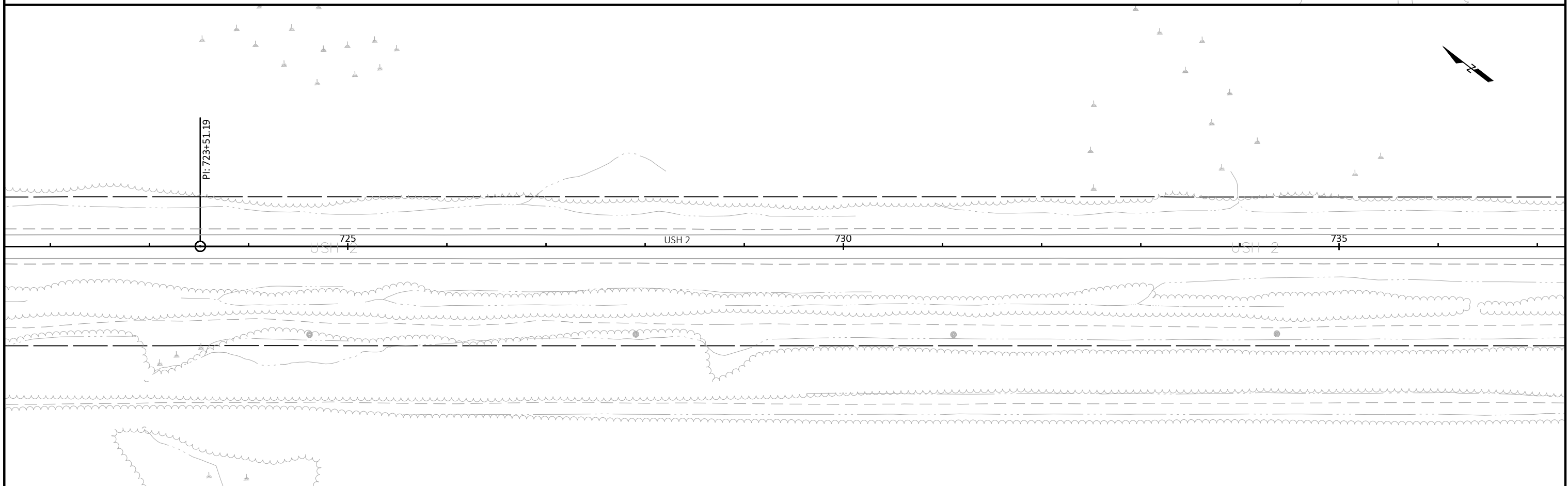
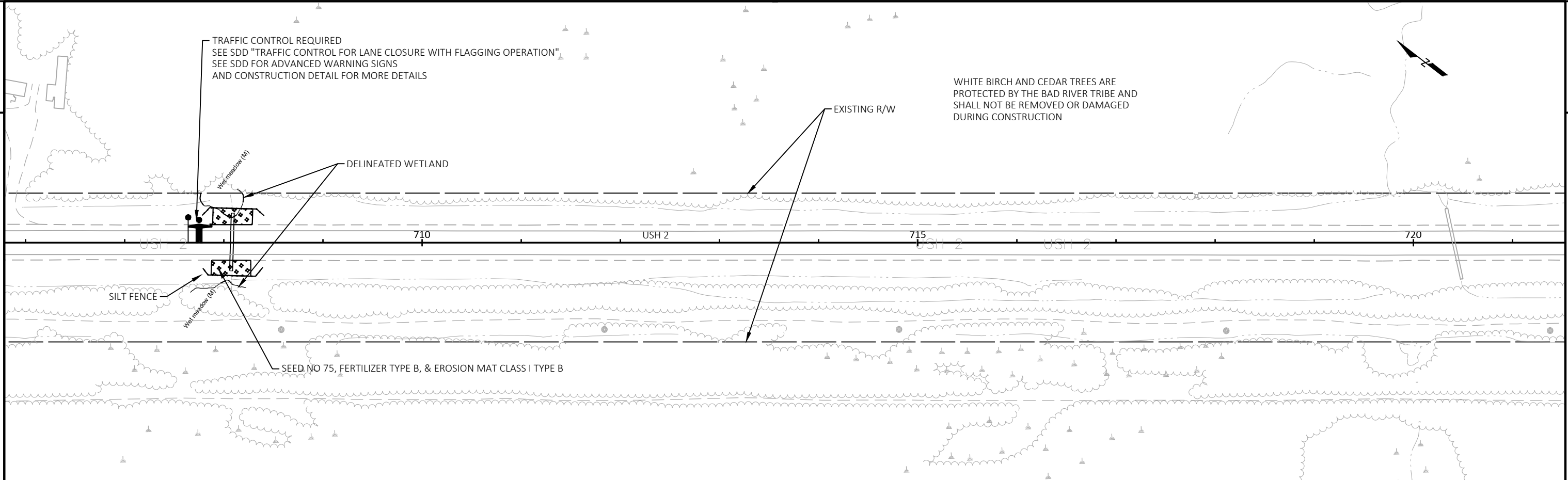

PROJECT NO: 1180-44-70	HWY: USH 2	COUNTY: ASHLAND & IRON	EROSION CONTROL & TRAFFIC CONTROL	SHEET	E
------------------------	------------	------------------------	-----------------------------------	-------	----------

WHITE BIRCH AND CEDAR TREES ARE PROTECTED BY THE BAD RIVER TRIBE AND SHALL NOT BE REMOVED OR DAMAGED DURING CONSTRUCTION

TRAFFIC CONTROL REQUIRED
SEE SDD "TRAFFIC CONTROL FOR LANE CLOSURE WITH FLAGGING OPERATION"
SEE SDD FOR ADVANCED WARNING SIGNS AND CONSTRUCTION DETAIL FOR MORE DETAILS

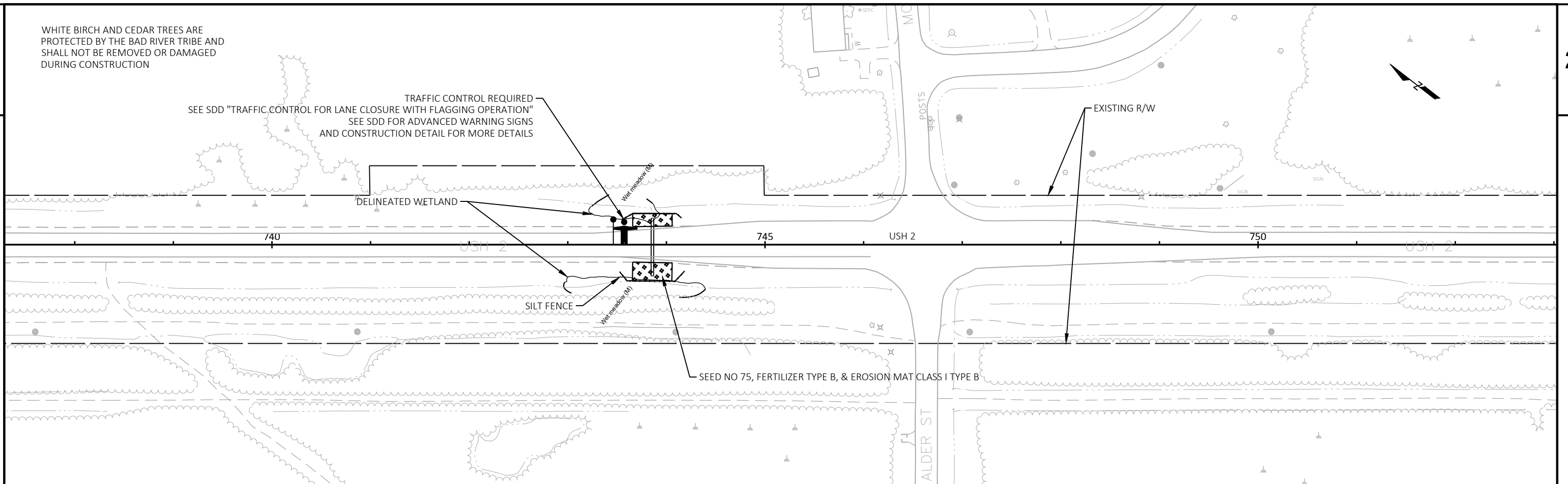

DELINEATED WATERSHED

SILT FENCE

TRAFFIC CONTROL REQUIRED
SEE SDD "TRAFFIC CONTROL FOR LANE CLOSURE WITH FLAGGING OPERATION"
SEE SDD FOR ADVANCED WARNING SIGNS AND CONSTRUCTION DETAIL FOR MORE DETAILS

EXISTING R/W

PI: 758+12.36

PC: 759+55.85

SEED NO 75, FERTILIZER TYPE B, & EROSION MAT CLASS I TYPE B

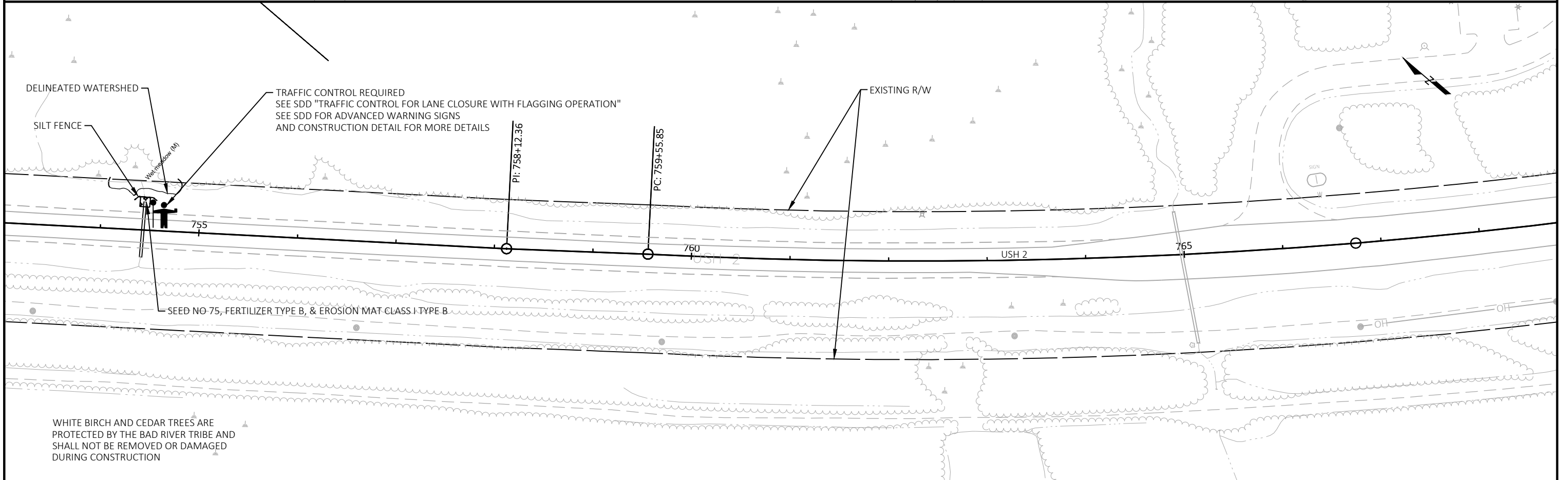

WHITE BIRCH AND CEDAR TREES ARE PROTECTED BY THE BAD RIVER TRIBE AND SHALL NOT BE REMOVED OR DAMAGED DURING CONSTRUCTION

WHITE BIRCH AND CEDAR TREES ARE PROTECTED BY THE BAD RIVER TRIBE AND SHALL NOT BE REMOVED OR DAMAGED DURING CONSTRUCTION

SEED NO 75, FERTILIZER TYPE B, & EROSION MAT CLASS I TYPE B

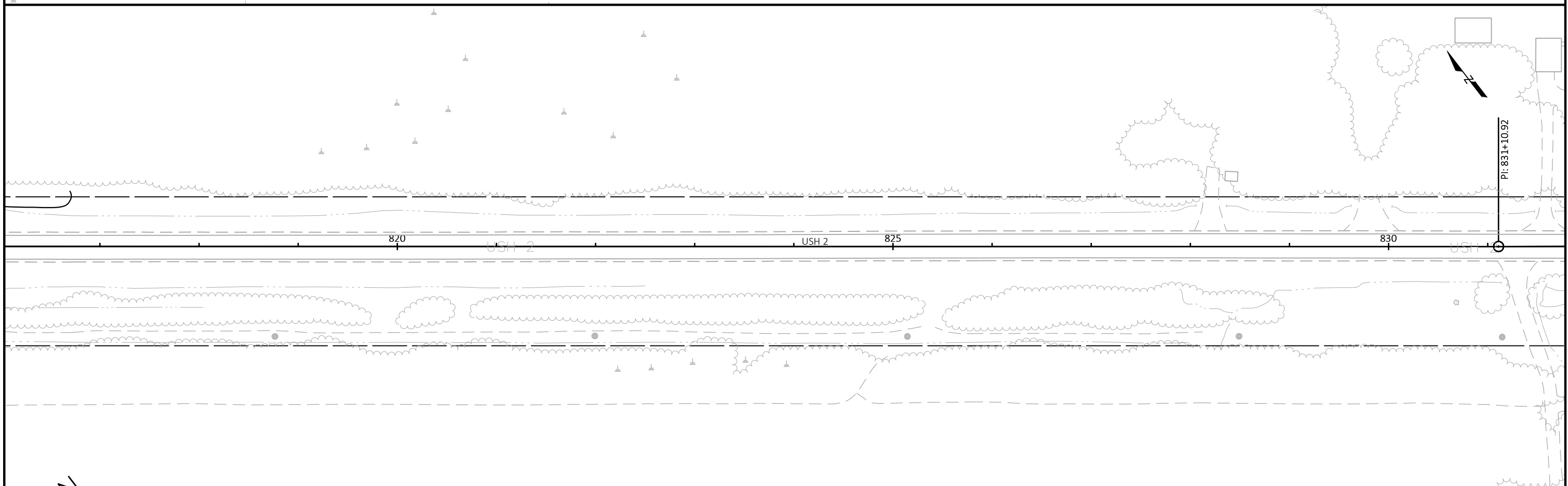
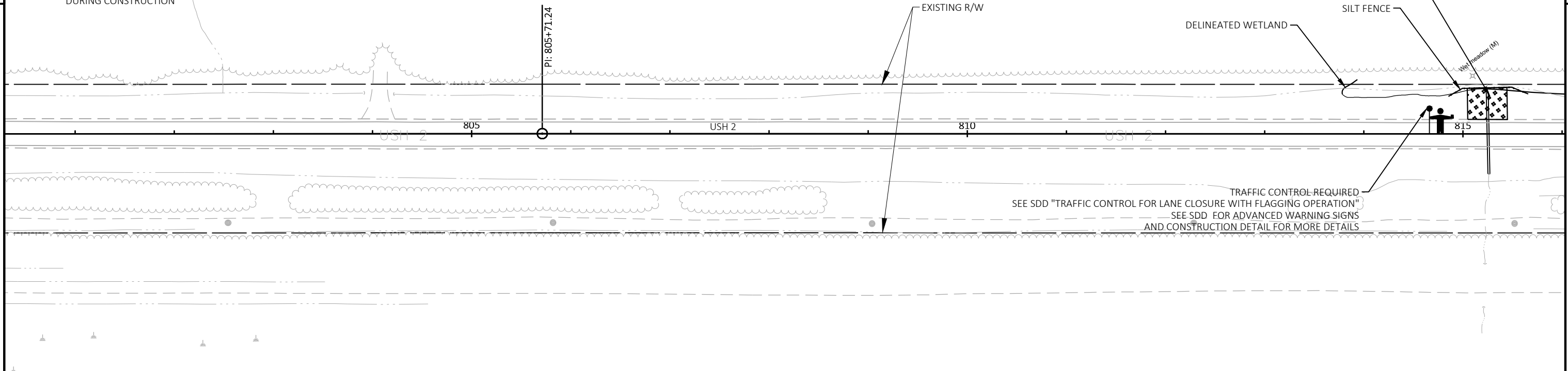

PROJECT NO: 1180-44-70	HWY: USH 2	COUNTY: ASHLAND & IRON	EROSION CONTROL & TRAFFIC CONTROL	SHEET	E
------------------------	------------	------------------------	-----------------------------------	-------	----------

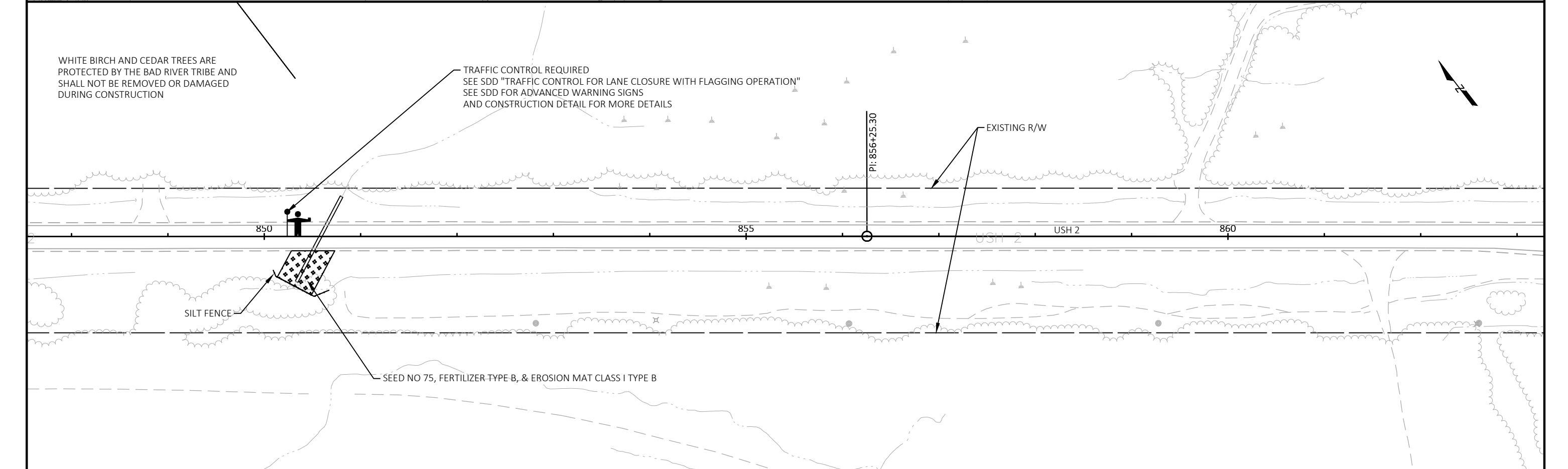
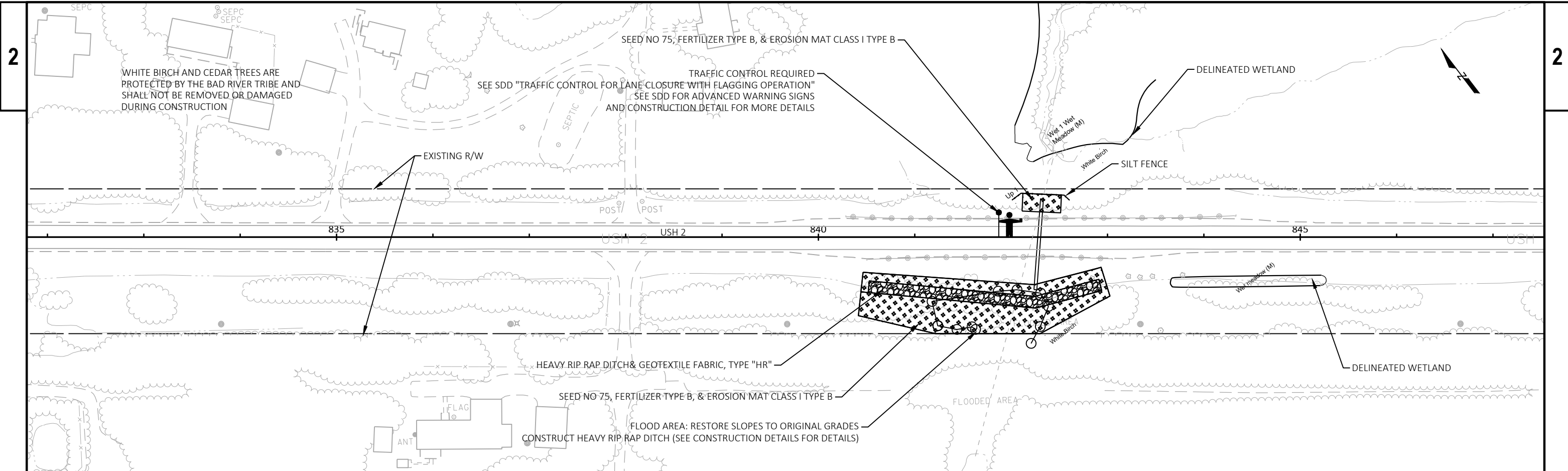

PROJECT NO: 1180-44-70	HWY: USH 2	COUNTY: ASHLAND & IRON	EROSION CONTROL & TRAFFIC CONTROL	SHEET	E
------------------------	------------	------------------------	-----------------------------------	-------	----------

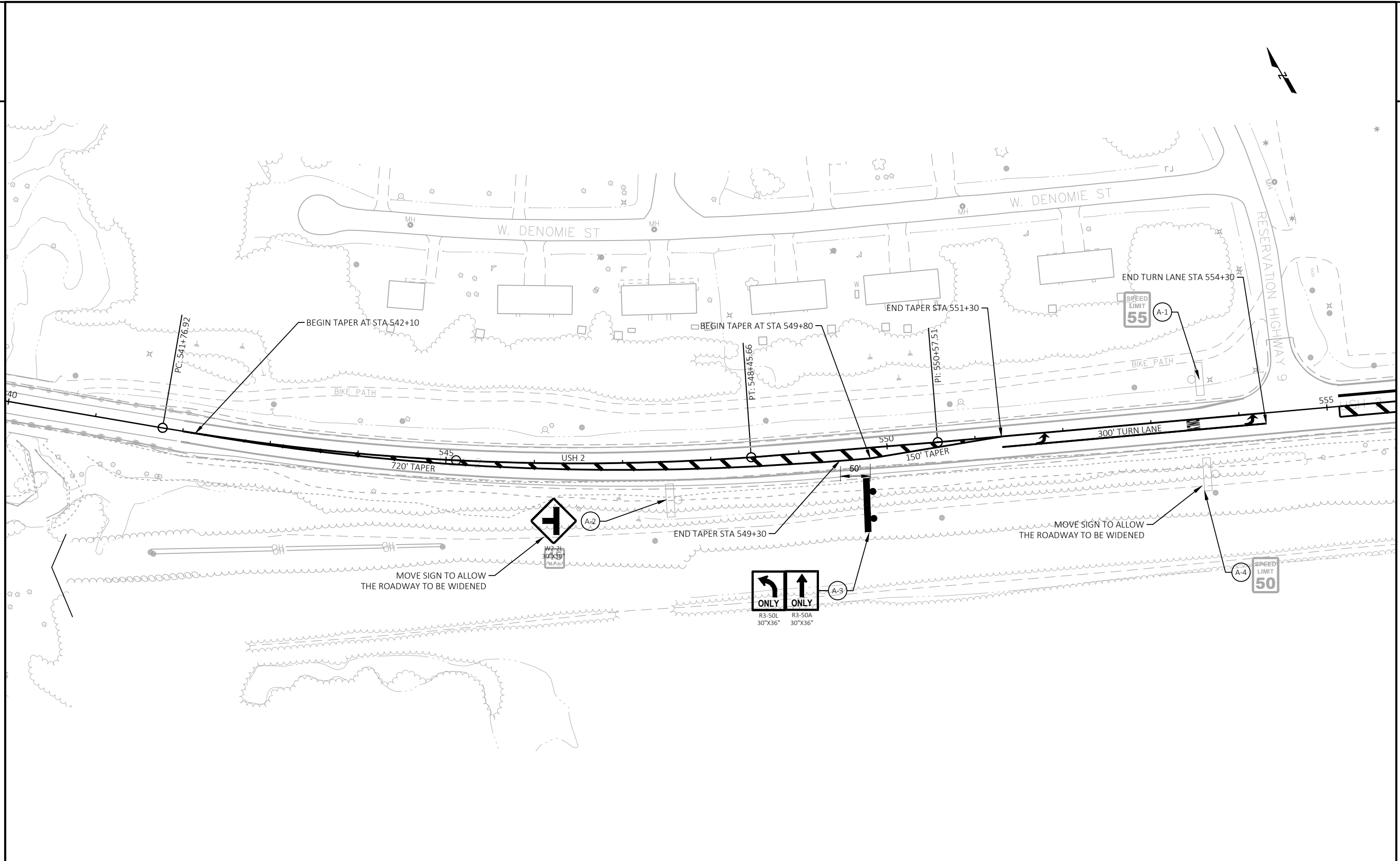

PROJECT NO: 1180-44-70	HWY: USH 2	COUNTY: ASHLAND & IRON	LANE RECONFIGURATION	SHEET	E
------------------------	------------	------------------------	----------------------	-------	---

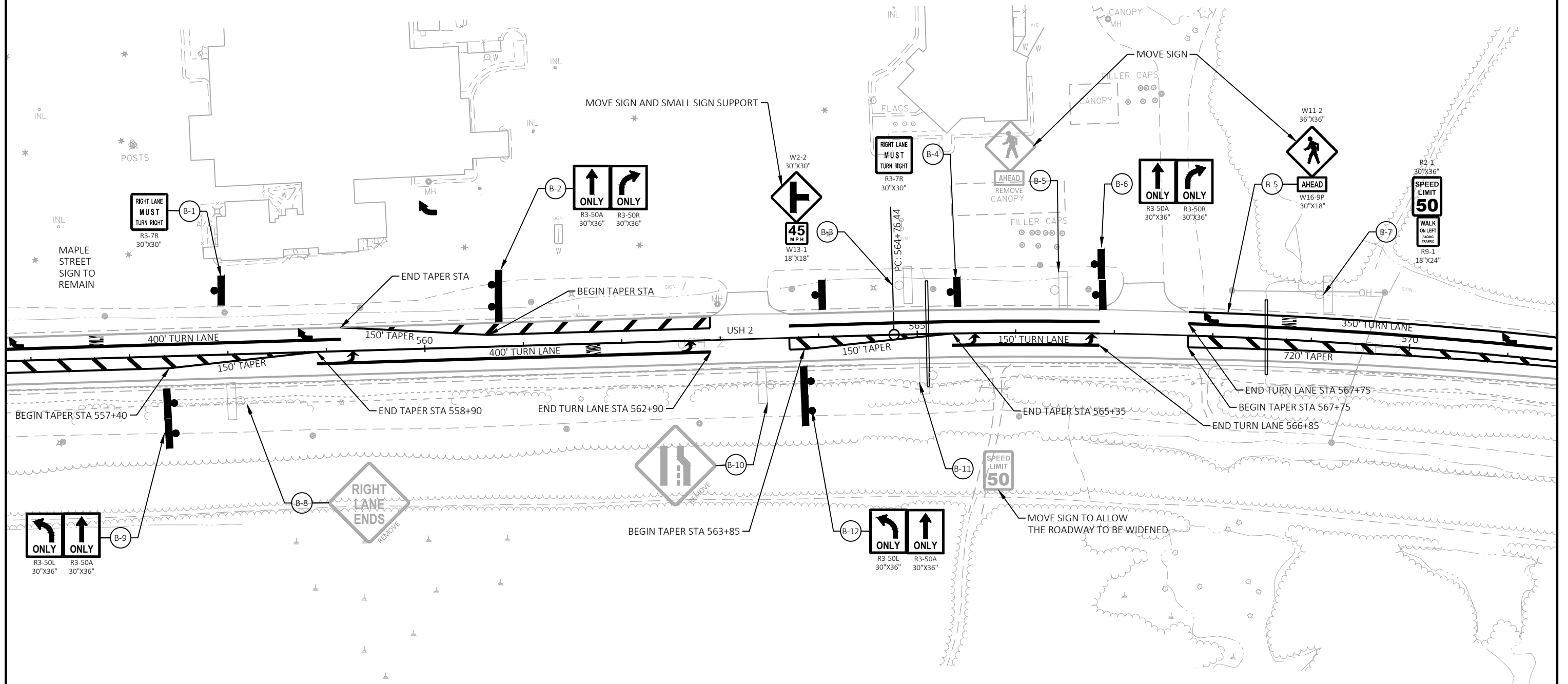

PROJECT NO: 1180-44-70	HWY: USH 2	COUNTY: ASHLAND & IRON	LANE RECONFIGURATION	SHEET	E
------------------------	------------	------------------------	----------------------	-------	---

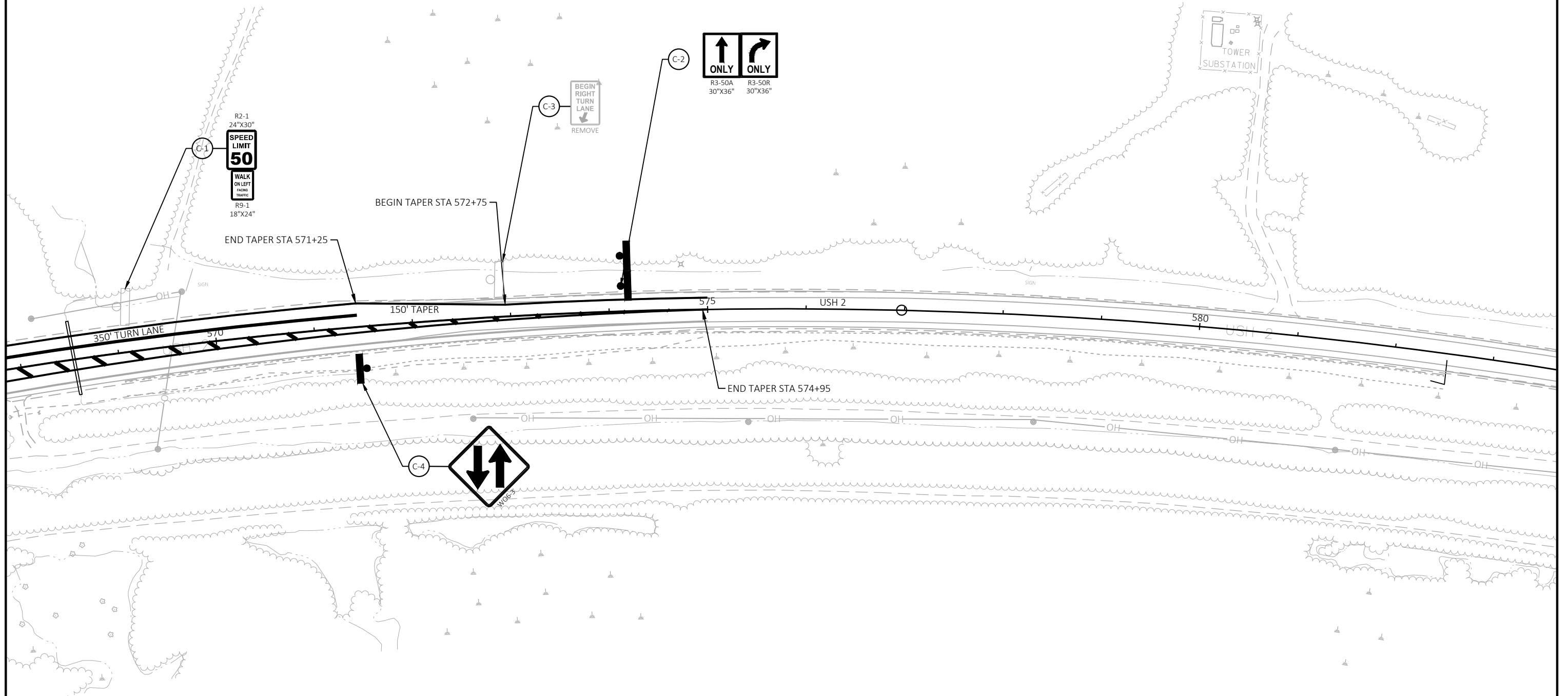

PROJECT NO: 1180-44-70

HWY: USH 2

COUNTY: ASHLAND & IRON

LANE RECONFIGURATION

SHEET

E

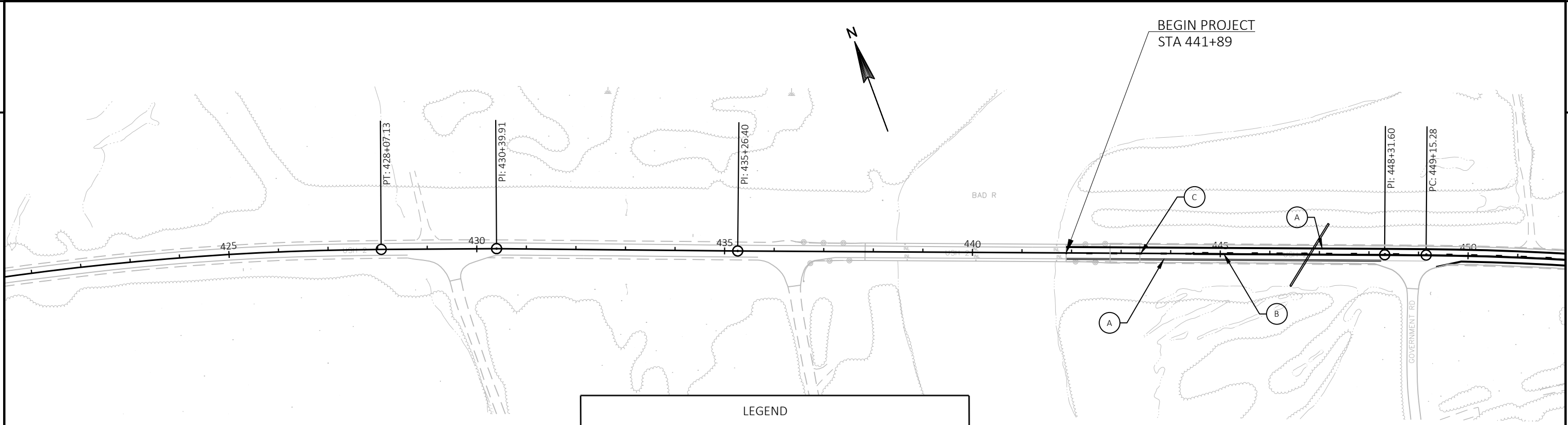

LEGEND

(A)	MARKING LINE GROOVED WET REF EPOXY 4-INCH, WHITE SOLID
(B)	MARKING LINE EPOXY 4-INCH, YELLOW SOLID
(C)	MARKING LINE EPOXY 4-INCH, YELLOW SKIPS, 12.5' LINES, 37.5' GAPS
(D)	MARKING LINE GROOVED WET REF EPOXY 8-INCH, WHITE SOLID
(E)	MARKING LINE EPOXY 4-INCH, WHITE SKIPS, 12.5 LINES, 37.5' GAPS

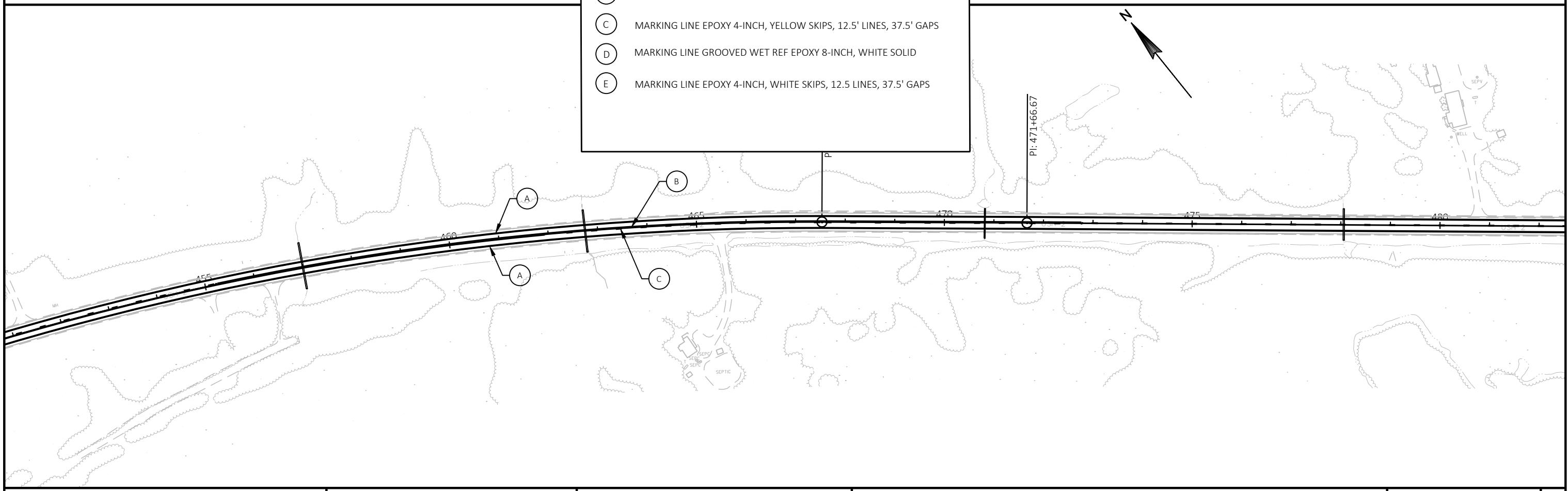

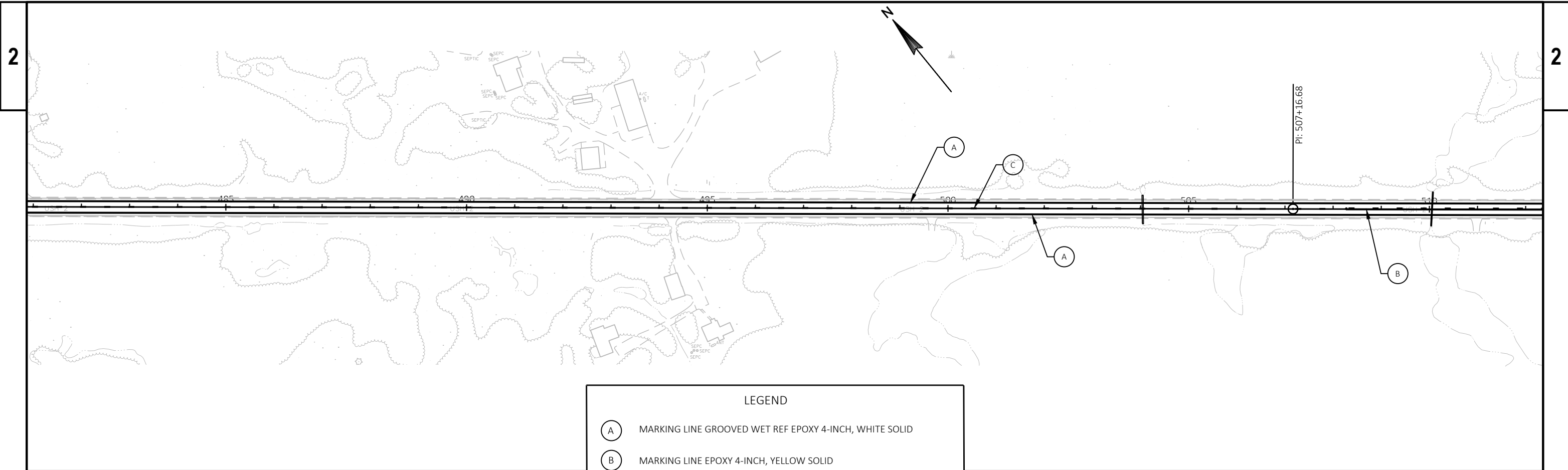

LEGEND

A	MARKING LINE GROOVED WET REF EPOXY 4-INCH, WHITE SOLID
B	MARKING LINE EPOXY 4-INCH, YELLOW SOLID
C	MARKING LINE EPOXY 4-INCH, YELLOW SKIPS, 12.5' LINES, 37.5' GAPS
D	MARKING LINE GROOVED WET REF EPOXY 8-INCH, WHITE SOLID
E	MARKING LINE EPOXY 4-INCH, WHITE SKIPS, 12.5 LINES, 37.5' GAPS

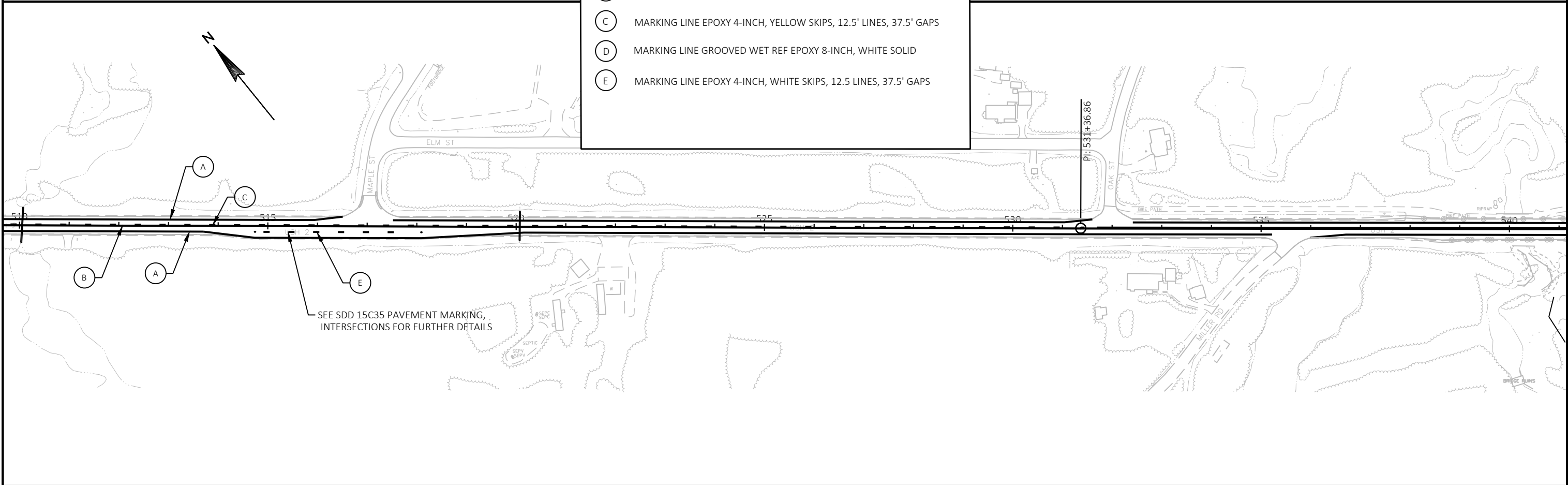

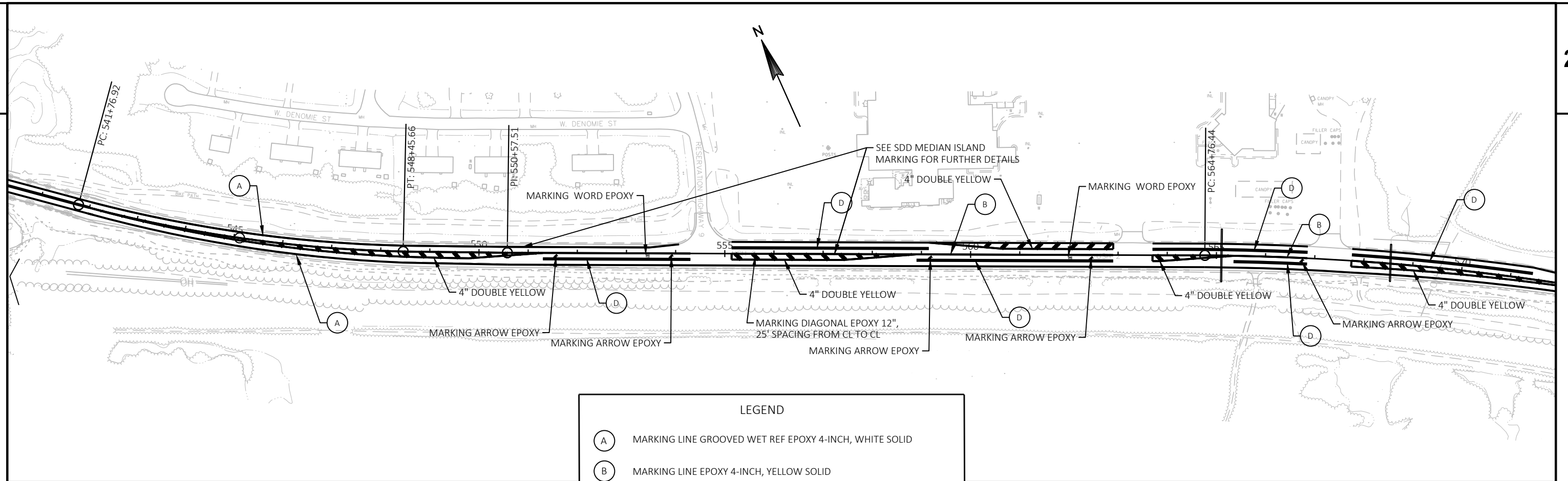

LEGEND

(A)	MARKING LINE GROOVED WET REF EPOXY 4-INCH, WHITE SOLID
(B)	MARKING LINE EPOXY 4-INCH, YELLOW SOLID
(C)	MARKING LINE EPOXY 4-INCH, YELLOW SKIPS, 12.5' LINES, 37.5' GAPS
(D)	MARKING LINE GROOVED WET REF EPOXY 8-INCH, WHITE SOLID
(E)	MARKING LINE EPOXY 4-INCH, WHITE SKIPS, 12.5 LINES, 37.5' GAPS

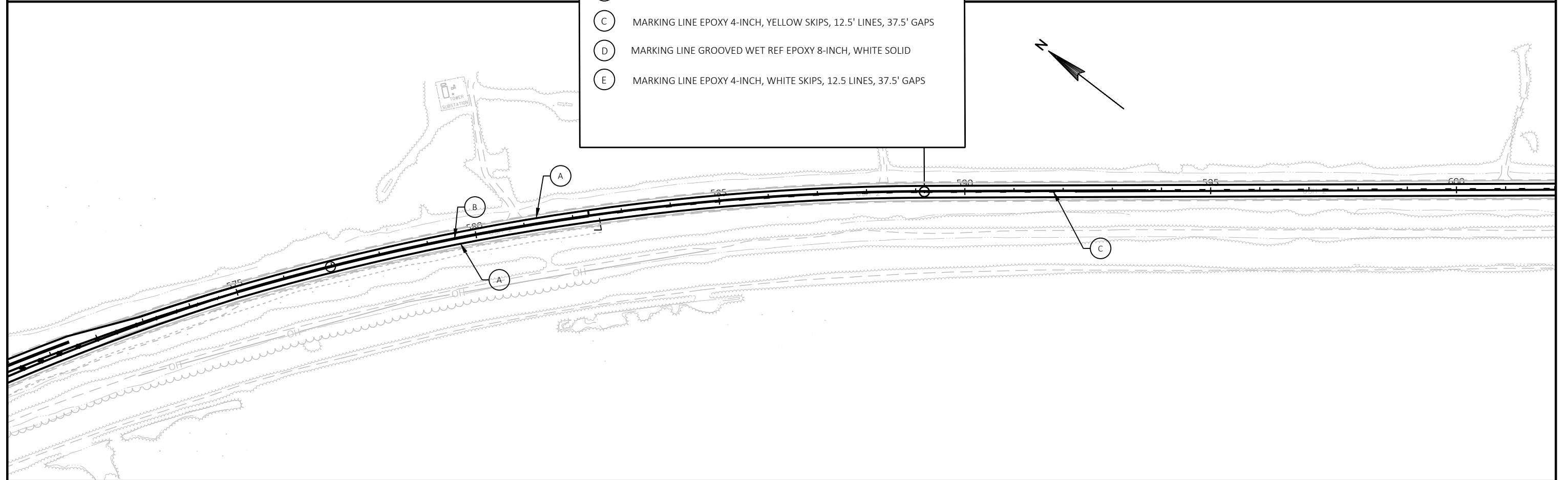

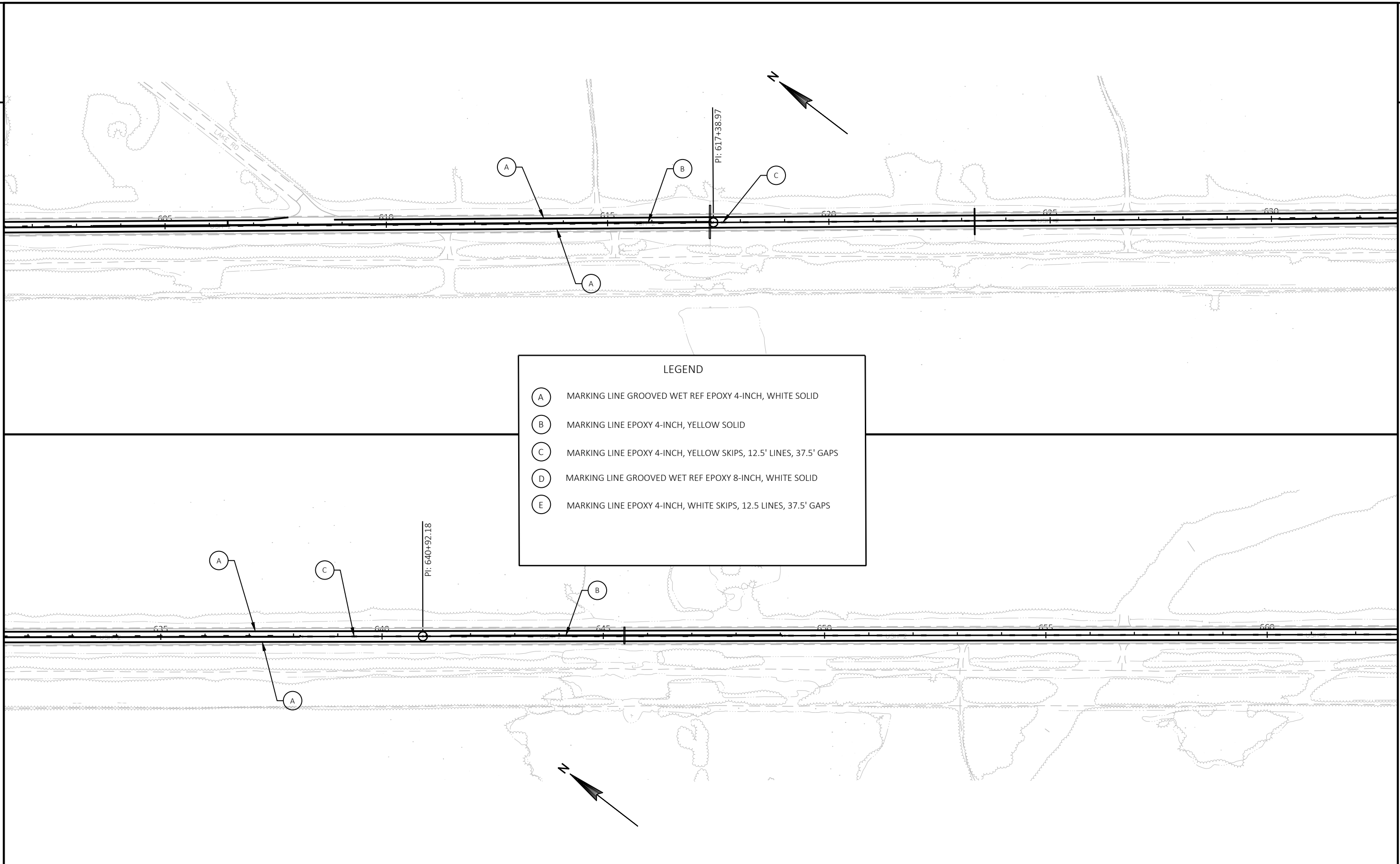

LEGEND

- (A) MARKING LINE GROOVED WET REF EPOXY 4-INCH, WHITE SOLID
- (B) MARKING LINE EPOXY 4-INCH, YELLOW SOLID
- (C) MARKING LINE EPOXY 4-INCH, YELLOW SKIPS, 12.5' LINES, 37.5' GAPS
- (D) MARKING LINE GROOVED WET REF EPOXY 8-INCH, WHITE SOLID
- (E) MARKING LINE EPOXY 4-INCH, WHITE SKIPS, 12.5 LINES, 37.5' GAPS

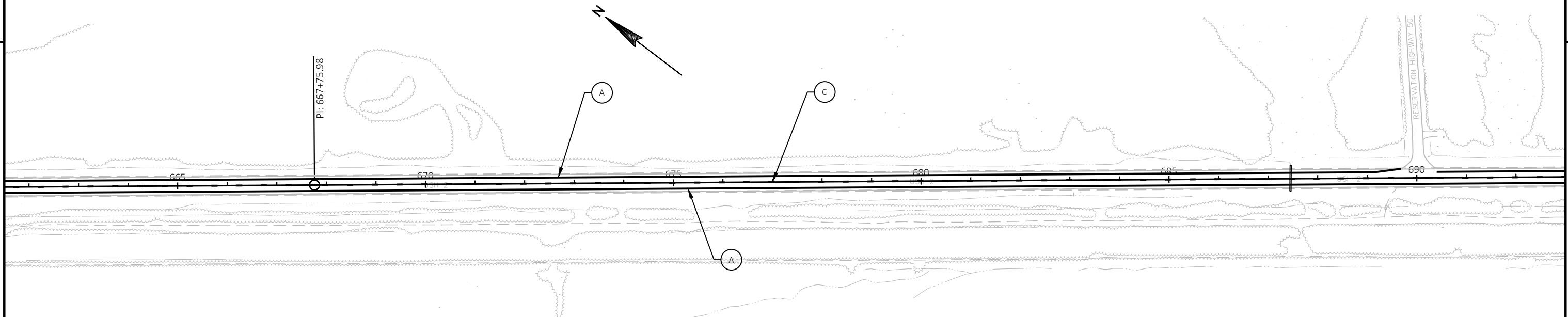

LEGEND

(A)	MARKING LINE GROOVED WET REF EPOXY 4-INCH, WHITE SOLID
(B)	MARKING LINE EPOXY 4-INCH, YELLOW SOLID
(C)	MARKING LINE EPOXY 4-INCH, YELLOW SKIPS, 12.5' LINES, 37.5' GAPS
(D)	MARKING LINE GROOVED WET REF EPOXY 8-INCH, WHITE SOLID
(E)	MARKING LINE EPOXY 4-INCH, WHITE SKIPS, 12.5 LINES, 37.5' GAPS

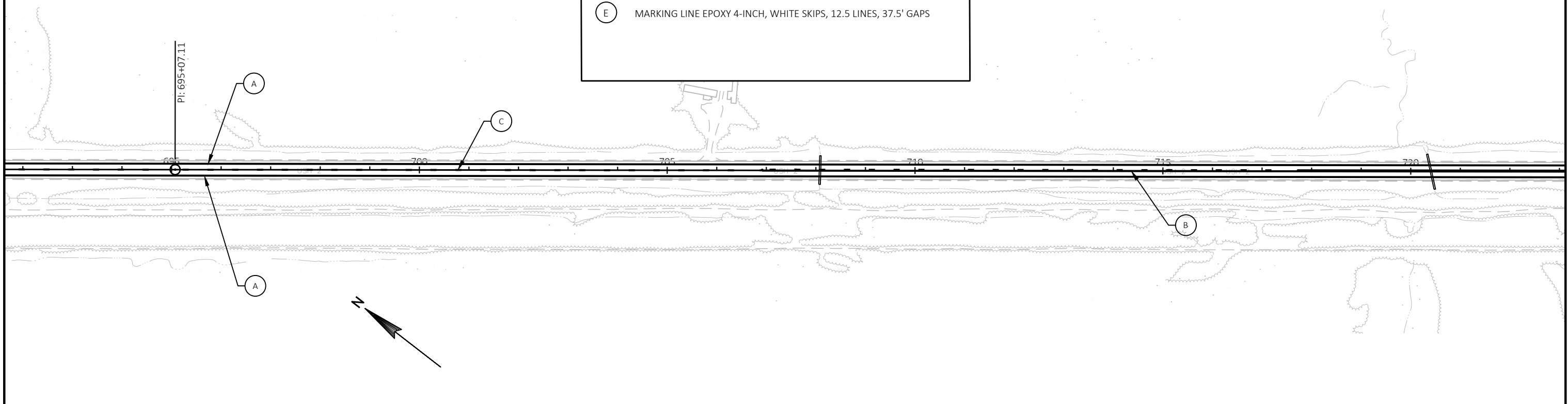

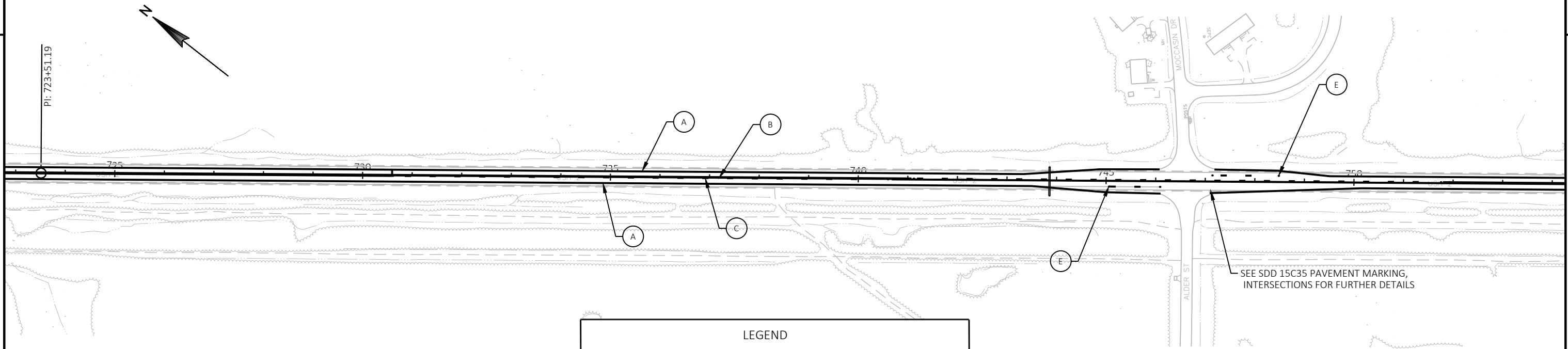

LEGEND

(A)	MARKING LINE GROOVED WET REF EPOXY 4-INCH, WHITE SOLID
(B)	MARKING LINE EPOXY 4-INCH, YELLOW SOLID
(C)	MARKING LINE EPOXY 4-INCH, YELLOW SKIPS, 12.5' LINES, 37.5' GAPS
(D)	MARKING LINE GROOVED WET REF EPOXY 8-INCH, WHITE SOLID
(E)	MARKING LINE EPOXY 4-INCH, WHITE SKIPS, 12.5 LINES, 37.5' GAPS

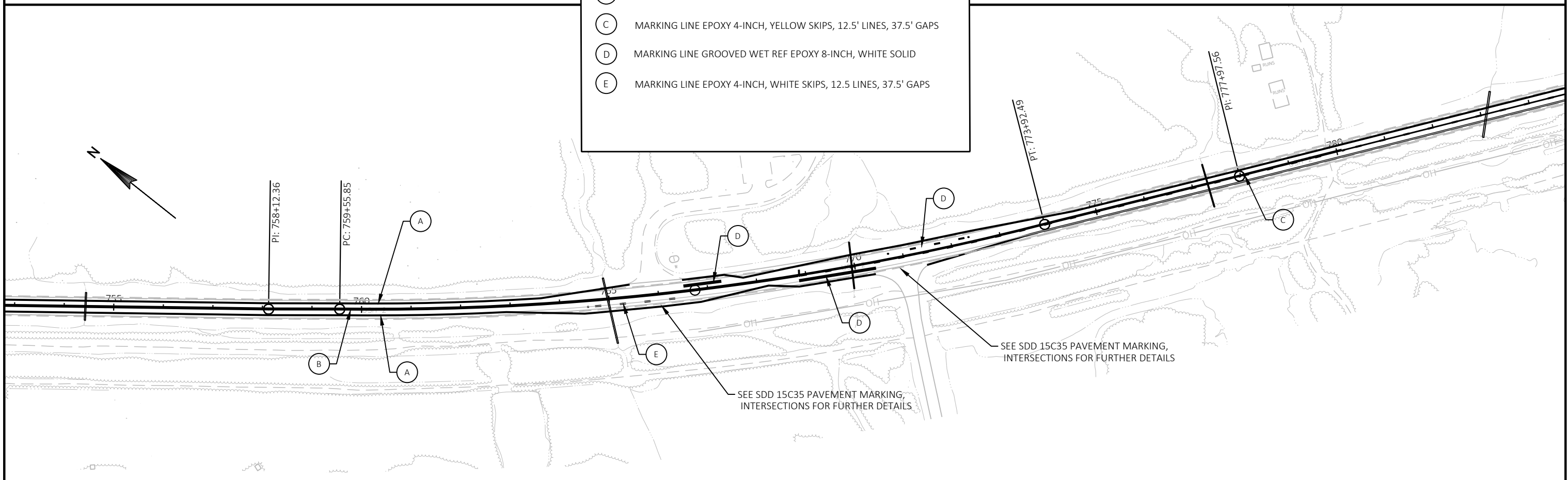

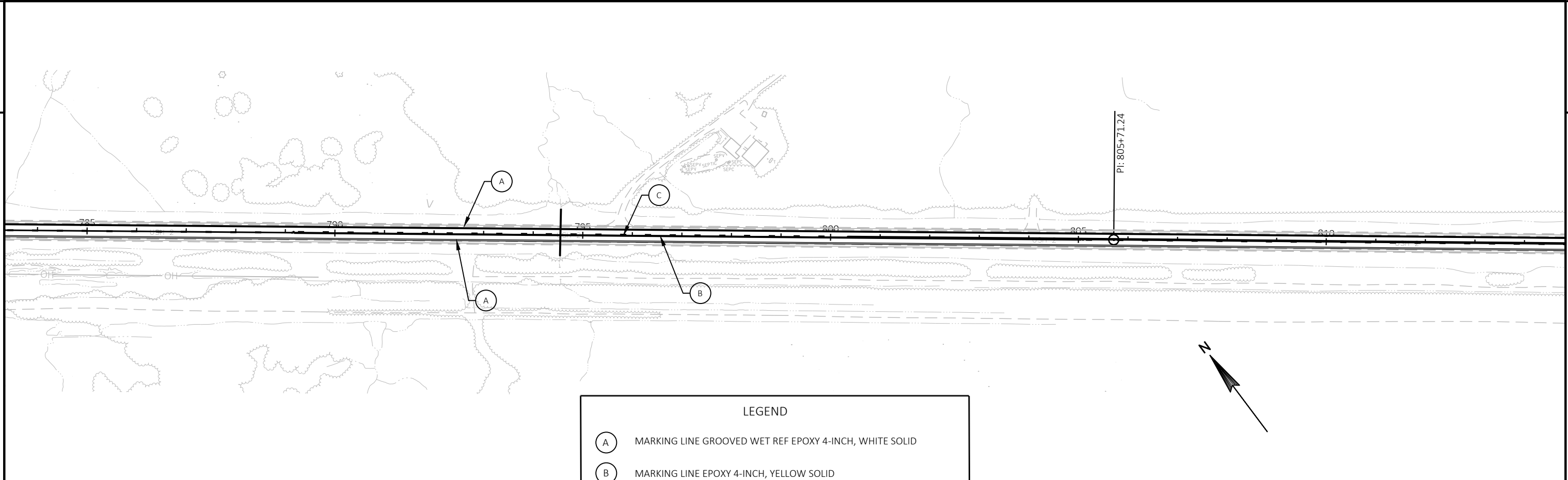

LEGEND

(A)	MARKING LINE GROOVED WET REF EPOXY 4-INCH, WHITE SOLID
(B)	MARKING LINE EPOXY 4-INCH, YELLOW SOLID
(C)	MARKING LINE EPOXY 4-INCH, YELLOW SKIPS, 12.5' LINES, 37.5' GAPS
(D)	MARKING LINE GROOVED WET REF EPOXY 8-INCH, WHITE SOLID
(E)	MARKING LINE EPOXY 4-INCH, WHITE SKIPS, 12.5 LINES, 37.5' GAPS

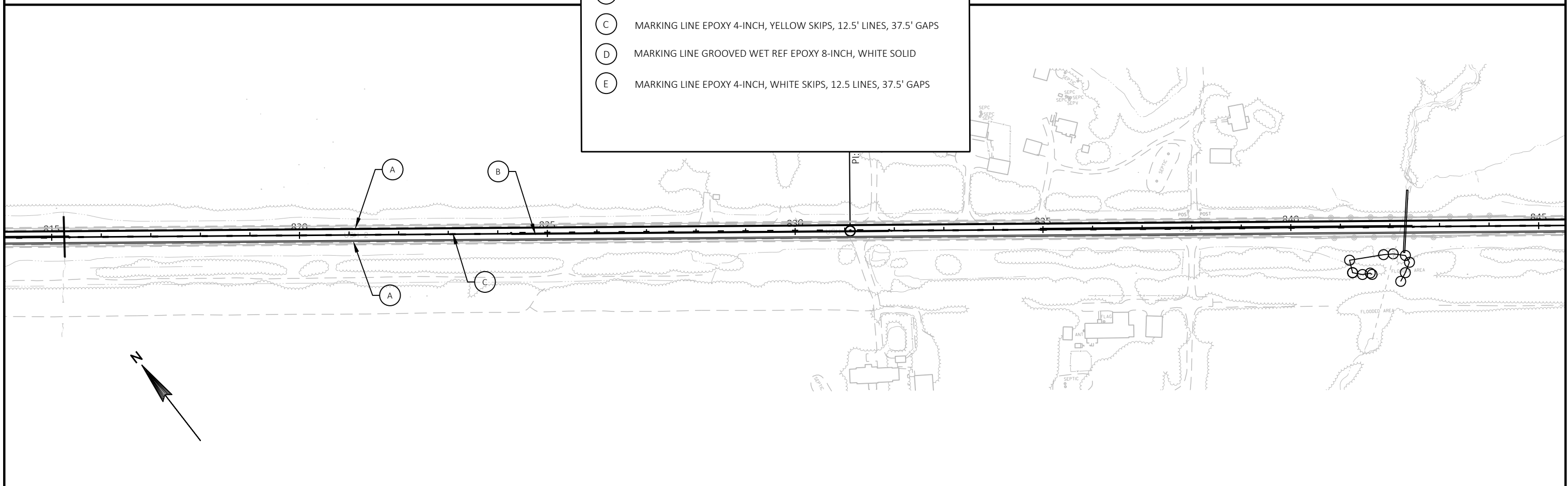

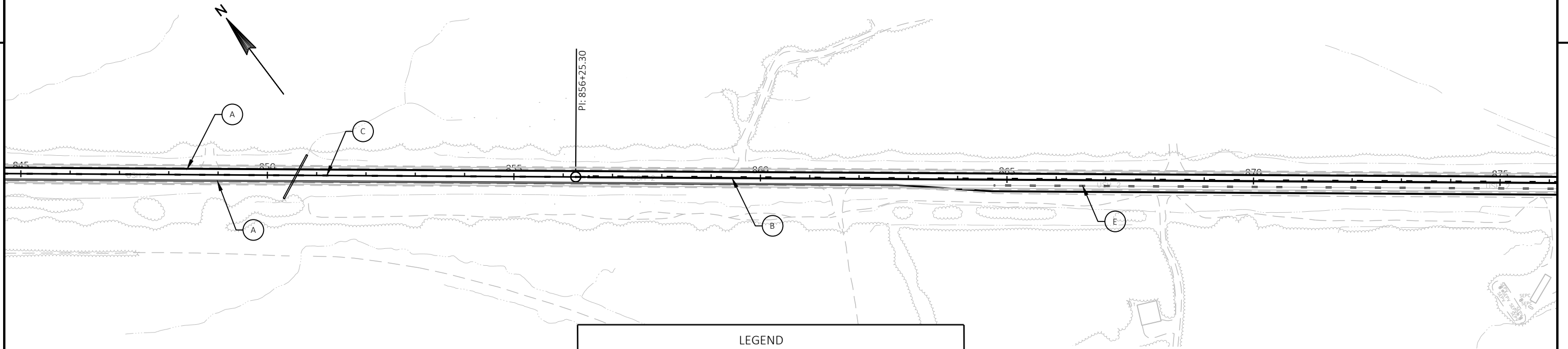

LEGEND

(A)	MARKING LINE GROOVED WET REF EPOXY 4-INCH, WHITE SOLID
(B)	MARKING LINE EPOXY 4-INCH, YELLOW SOLID
(C)	MARKING LINE EPOXY 4-INCH, YELLOW SKIPS, 12.5' LINES, 37.5' GAPS
(D)	MARKING LINE GROOVED WET REF EPOXY 8-INCH, WHITE SOLID
(E)	MARKING LINE EPOXY 4-INCH, WHITE SKIPS, 12.5 LINES, 37.5' GAPS

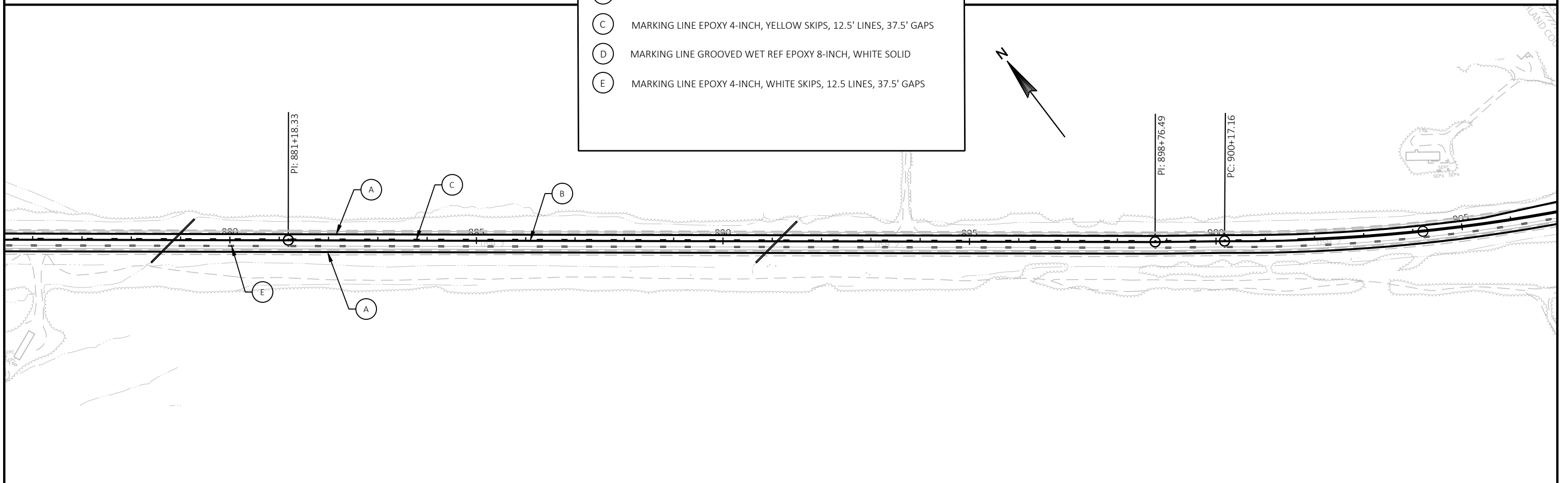

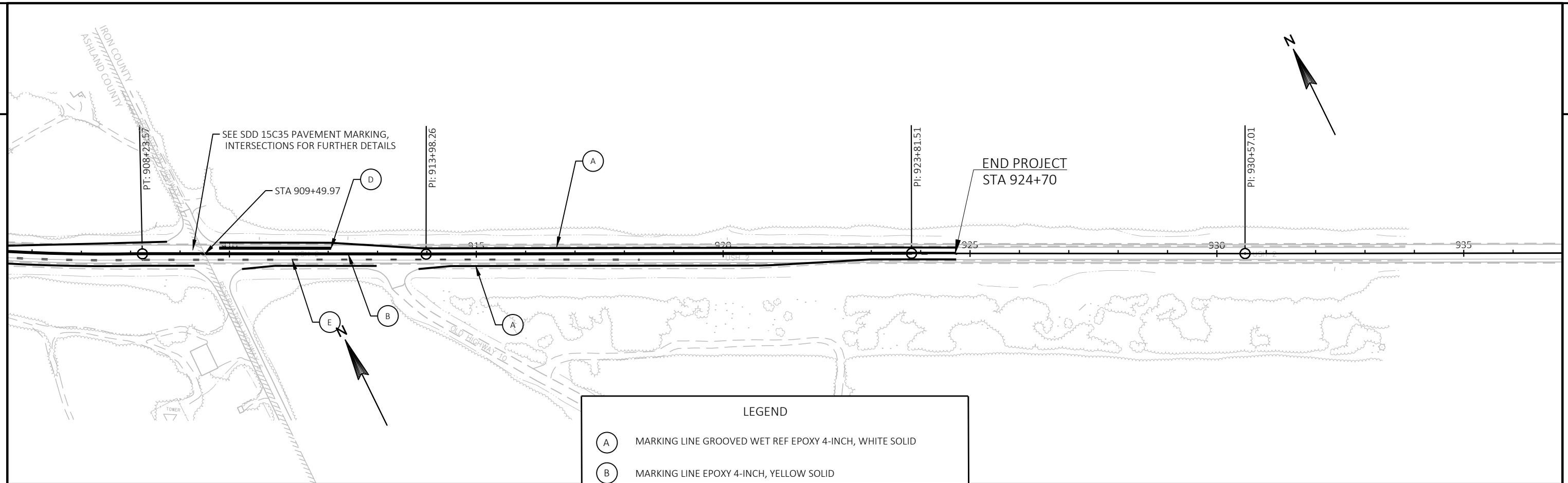

LEGEND

(A)	MARKING LINE GROOVED WET REF EPOXY 4-INCH, WHITE SOLID
(B)	MARKING LINE EPOXY 4-INCH, YELLOW SOLID
(C)	MARKING LINE EPOXY 4-INCH, YELLOW SKIPS, 12.5' LINES, 37.5' GAPS
(D)	MARKING LINE GROOVED WET REF EPOXY 8-INCH, WHITE SOLID
(E)	MARKING LINE EPOXY 4-INCH, WHITE SKIPS, 12.5 LINES, 37.5' GAPS

Estimate Of Quantities

1180-44-70

Line	Item	Item Description	Unit	Total	Qty
0002	201.0105	Clearing	STA	21.000	21.000
0004	201.0205	Grubbing	STA	21.000	21.000
0006	203.0100	Removing Small Pipe Culverts	EACH	7.000	7.000
0008	204.0110	Removing Asphaltic Surface	SY	2,275.000	2,275.000
0010	204.0115	Removing Asphaltic Surface Butt Joints	SY	512.000	512.000
0012	204.0120	Removing Asphaltic Surface Milling	SY	204,439.000	204,439.000
0014	205.0100	Excavation Common	CY	5,724.000	5,724.000
0016	205.0400	Excavation Marsh	CY	879.000	879.000
0018	208.1100	Select Borrow	CY	5,967.000	5,967.000
0020	211.0101	Prepare Foundation for Asphaltic Paving (project) 01. 1180-44-70	EACH	1.000	1.000
0022	213.0100	Finishing Roadway (project) 01. 1180-44-70	EACH	1.000	1.000
0024	305.0110	Base Aggregate Dense 3/4-Inch	TON	5,400.000	5,400.000
0026	305.0120	Base Aggregate Dense 1 1/4-Inch	TON	6,201.000	6,201.000
0028	455.0605	Tack Coat	GAL	13,005.000	13,005.000
0030	460.0115.S	HMA Pavement Test Strips Volumetrics	EACH	1.000	1.000
0032	460.0120.S	HMA Pavement Test Strips Density	EACH	1.000	1.000
0034	460.2000	Incentive Density HMA Pavement	DOL	9,760.000	9,760.000
0036	460.6244	HMA Pavement 4 MT 58-34 S	TON	9,319.000	9,319.000
0038	460.8644	HMA Pavement 4 SMA 58-34 V	TON	15,247.000	15,247.000
0040	460.9000.S	Material Transfer Vehicle	EACH	1.000	1.000
0042	465.0105	Asphaltic Surface	TON	321.000	321.000
0044	465.0110	Asphaltic Surface Patching	TON	50.000	50.000
0046	465.0120	Asphaltic Surface Driveways and Field Entrances	TON	62.000	62.000
0048	465.0425	Asphaltic Shoulder Rumble Strips 2-Lane Rural	LF	65,622.000	65,622.000
0050	465.0475	Asphalt Centerline Rumble Strips 2-Lane Rural	LF	48,281.000	48,281.000
0052	520.8000	Concrete Collars for Pipe	EACH	2.000	2.000
0054	520.8700	Cleaning Culvert Pipes	EACH	4.000	4.000
0056	522.0124	Culvert Pipe Reinforced Concrete Class III 24-Inch	LF	64.000	64.000
0058	522.0130	Culvert Pipe Reinforced Concrete Class III 30-Inch	LF	266.000	266.000
0060	522.0136	Culvert Pipe Reinforced Concrete Class III 36-Inch	LF	152.000	152.000
0062	522.1024	Apron Endwalls for Culvert Pipe Reinforced Concrete 24-Inch	EACH	5.000	5.000
0064	522.1030	Apron Endwalls for Culvert Pipe Reinforced Concrete 30-Inch	EACH	11.000	11.000
0066	522.1036	Apron Endwalls for Culvert Pipe Reinforced Concrete 36-Inch	EACH	5.000	5.000
0068	606.0300	Riprap Heavy	CY	255.000	255.000
0070	618.0100	Maintenance And Repair of Haul Roads (project) 01. 1180-44-70	EACH	1.000	1.000
0072	619.1000	Mobilization	EACH	1.000	1.000
0074	624.0100	Water	MGAL	112.000	112.000
0076	625.0100	Topsoil	SY	5,659.000	5,659.000
0078	625.0500	Salvaged Topsoil	SY	3,000.000	3,000.000
0080	628.1504	Silt Fence	LF	4,470.000	4,470.000
0082	628.1520	Silt Fence Maintenance	LF	4,470.000	4,470.000
0084	628.1905	Mobilizations Erosion Control	EACH	2.000	2.000
0086	628.1910	Mobilizations Emergency Erosion Control	EACH	2.000	2.000
0088	628.2004	Erosion Mat Class I Type B	SY	8,659.000	8,659.000
0090	628.2008	Erosion Mat Urban Class I Type B	SY	3,000.000	3,000.000
0092	628.7555	Culvert Pipe Checks	EACH	21.000	21.000
0094	629.0210	Fertilizer Type B	CWT	5.450	5.450
0096	630.0175	Seeding Mixture No. 75	LB	55.000	55.000
0098	633.5200	Markers Culvert End	EACH	55.000	55.000

Estimate Of Quantities

1180-44-70

Line	Item	Item Description	Unit	Total	Qty
0100	634.0616	Posts Wood 4x6-Inch X 16-FT	EACH	16.000	16.000
0102	637.2210	Signs Type II Reflective H	SF	113.000	113.000
0104	637.2230	Signs Type II Reflective F	SF	16.000	16.000
0106	638.2102	Moving Signs Type II	EACH	4.000	4.000
0108	638.2602	Removing Signs Type II	EACH	2.000	2.000
0110	638.3000	Removing Small Sign Supports	EACH	2.000	2.000
0112	638.4000	Moving Small Sign Supports	EACH	3.000	3.000
0114	642.5001	Field Office Type B	EACH	1.000	1.000
0116	643.0300	Traffic Control Drums	DAY	2,080.000	2,080.000
0118	643.0715	Traffic Control Warning Lights Type C	DAY	300.000	300.000
0120	643.0900	Traffic Control Signs	DAY	2,520.000	2,520.000
0122	643.5000	Traffic Control	EACH	1.000	1.000
0124	645.0120	Geotextile Type HR	SY	2,300.000	2,300.000
0126	646.1020	Marking Line Epoxy 4-Inch	LF	160,180.000	160,180.000
0128	646.1040	Marking Line Grooved Wet Ref Epoxy 4-Inch	LF	99,623.000	99,623.000
0130	646.3040	Marking Line Grooved Wet Ref Epoxy 8-Inch	LF	2,395.000	2,395.000
0132	646.4520	Marking Line Same Day Epoxy 4-Inch	LF	47,887.000	47,887.000
0134	646.5020	Marking Arrow Epoxy	EACH	5.000	5.000
0136	646.5120	Marking Word Epoxy	EACH	2.000	2.000
0138	646.7120	Marking Diagonal Epoxy 12-Inch	LF	750.000	750.000
0140	649.0105	Temporary Marking Line Paint 4-Inch	LF	41,718.000	41,718.000
0142	650.4500	Construction Staking Subgrade	LF	3,300.000	3,300.000
0144	650.5000	Construction Staking Base	LF	3,300.000	3,300.000
0146	650.6000	Construction Staking Pipe Culverts	EACH	7.000	7.000
0148	650.8000	Construction Staking Resurfacing Reference	LF	48,281.000	48,281.000
0150	650.9911	Construction Staking Supplemental Control (project) 01. 1180-44-70	EACH	1.000	1.000
0152	650.9920	Construction Staking Slope Stakes	LF	3,300.000	3,300.000
0154	690.0150	Sawing Asphalt	LF	3,286.000	3,286.000
0156	740.0440	Incentive IRI Ride	DOL	36,560.000	36,560.000
0158	ASP.1T0A	On-the-Job Training Apprentice at \$5.00/HR	HRS	1,200.000	1,200.000
0160	ASP.1T0G	On-the-Job Training Graduate at \$5.00/HR	HRS	1,200.000	1,200.000
0162	SPV.0060	Special 01. Resetting Culvert Sections	EACH	41.000	41.000
0164	SPV.0060	Special 02. Denomiee Creek Restoration	EACH	1.000	1.000

201.0105 CLEARING

STATION	TO	STATION	LOCATION	201.0105 CLEARING STA
555+00	-	576+00	RT	21
TOTAL 0010				21

201.0205 GRUBBING

STATION	TO	STATION	LOCATION	201.0205 GRUBBING STA
555+00	-	576+00	RT	21
TOTAL 0010				21

204.0110 REMOVING ASPHALTIC SURFACE

STATION	TO	STATION	LOCATION	204.0110 REMOVING ASPHALTIC SURFACE SY
541+75	-	575+00	RT	2,275
TOTAL 0010				2,275

203.0100
REMOVING SMALL
PIPE CULVERTS

STATION	LOCATION	EACH	REMARKS
462+73	RT<	1	30"X 86'
470+77	RT<	1	24" X 60'
478+05	RT<	1	30" X 54'
687+35	RT<	1	30" X 48'
708+10	RT<	1	36" x 58'
743+80	RT<	1	30 " X 58'
850+60	RT<	1	36" X 100'
TOTAL 0010		7	

204.0115 REMOVING ASPHALTIC SURFACE BUTT JOINTS

204.0115 REMOVING ASPHALTIC SURFACE BUTT JOINTS		
STATION	LOCATION	SY
441+89	MAINLINE	60
448+80	GOVERNMENT RD	14
494+00	DRIVEWAY	12
517+00	MAPLE STREET	40
532+00	OAK STREET	15
535+50	MILLER RD	13
554+50	RESERVATION HWY 9	15
563+00	COMMERCIAL ENTRANCE	29
567+00	COMMERCIAL ENTRANCE	33
608+25	LAKE RD	16
690+00	RESERVATION HWY 50	14
746+50	ALDER ST	16
746+50	MOCCASIN DR	16
766+00	DRIVEWAY	44
771+00	F ACCEFS RD	16
831+00	DRIVEWAY	16
835+00	DRIVEWAY	11
838+00	DRIVEWAY	11
868+00	DRIVEWAY	11
909+50	RESERVATION HWY 7	14
909+50	RESERVATION HWY 5	15
913+25	OLD HWY 10	19
924+70	MAINLINE	60
TOTAL 0010		512

204.0120 REMOVNG ASPHALTIC SURFACE MILLING

208.1100 SELECT BORROW

3

3

STATION	LOCATION	204.0120 REMOVING ASPHALTIC SURFACE MILLING SY
974+70	MAIN INF	200,626
448+80	GOVERNMENT RD	356
494+00	DRIVEWAY	79
517+00	MAPLE STREET	271
532+00	OAK STREET	74
535+50	MILLER RD	169
554+50	RESERVATION HWY 9	164
563+00	COMMERCIAL ENTRANCE	307
567+00	COMMERCIAL ENTRANCE	80
608+25	LAKE RD	95
690+00	RESERVATION HWY 50	251
746+50	ALDER ST	299
746+50	MOCCASIN DR	321
766+00	DRIVEWAY	123
771+00	F ACCFS RD	387
831+00	DRIVEWAY	45
835+00	DRIVEWAY	39
838+00	DRIVEWAY	39
868+00	DRIVEWAY	32
909+50	RESERVATION HWY 7	269
909+50	RESERVATION HWY 5	274
913+25	OLD HWY 10	188
TOTAL 0010		204,439

STATION	TO	STATION	LOCATION	208.1100 SELECT BORROW CY
541+77	-	576+00	RT	5,967
TOTAL 0010				5,967

LOCATION	211.0101 PREPARE FOUNDATION FOR ASPHALTIC PAVING (1180-44-70) EACH
PROJECT	1
TOTAL 0010	1

205.0100 EXCAVATION COMMON

213.0100.01 FINISHING ROADWAY (1180-44-70)

STATION	TO	STATION	LOCATION	205.0100 EXCAVATION COMMON CY
541+77	-	576+00	RT	5,724
TOTAL 0010				5,724

LOCATION	213.0100.01 FINISHING ROADWAY (1180- 44-70) EACH
PROJECT	1
TOTAL 0010	1

LOCATION	205.0400 EXCAVATION MARSH CY
PROJECT	879
TOTAL 0010	879

3

305.0110 BASE AGGREGATE DENSE 3/4-INCH

STATION	TO	STATION	LOCATION	305.0110 BASE AGGREGATE DENSE 3/4-INCH TON
441+89	-	924+70	LT/RT	5,400
TOTAL 0010				5,400

305.0120 BASE AGGREGATE DENSE 1 1/4-INCH

STATION	TO	STATION	LOCATION	305.0120 BASE AGGREGATE DENSE 1 1/4-INCH TON
541+77	-	576+00	RT	6,201
TOTAL 0010				6,201

455.0605 TACK COAT

STATION	TO	STATION	LOCATION	455.0605 TACK COAT GAL
441+89	-	924+70	MAINLINE/SHOULDER	12,038
		448+80	GOVERNMENT RD	21
		517+00	MAPLE STREET	16
		532+00	OAK STREET	10
		535+50	MILLER RD	10
		554+50	RESERVATION HWY 9	18
		608+25	LAKE RD	15
		690+00	RESERVATION HWY 50	10
		746+50	ALDER ST	19
		746+50	MOCCASIN DR	18
		771+00	E ACCES RD	23
		909+50	RESERVATION HWY 7	16
		909+50	RESERVATION HWY 5	16
		913+25	OLD HWY 10	11
			LOWER LAYER RECONFIGURE	381
			MIDDLE LAYER RECONFIGURE	381
TOTAL 0010				13,005

460.0115.S
HMA PAVEMENT
TEST STRIPS
VOLUMETRICS
EACH

LOCATION	EACH
PROJECT	1
TOTAL 0010	1

3

460.6244 HMA PAVEMENT 4 MT 58-34 S

LOCATION	460.0120.S HMA PAVEMENT TEST STRIPS DENSITY EACH
PROJECT	1
TOTAL 0010	1

STATION	TO	STATION	LOCATION	460.6244 HMA PAVEMENT 4 MT 58-34 S TON
441+89	-	924+70	LT/RT SHOULDER	7,316
		448+80	GOVERNMENT RD	40
		517+00	MAPLE STREET	30
		532+00	OAK STREET	19
541+10	-	575+00	LANE WIDENING	1,620
		535+50	MILLER RD	18
		554+50	RESERVATION HWY 9	34
		608+25	LAKE RD	28
		690+00	RESERVATION HWY 50	19
		746+50	ALDER ST	36
		746+50	MOCCASIN DR	33
		771+00	E ACCES RD	43
		909+50	RESERVATION HWY 7	30
		909+50	RESERVATION HWY 5	31
		913+25	OLD HWY 10	21
			TOTAL 0010	9,319

460.8644 HMA PAVEMENT 4 SMA 58-34 V

STATION	TO	STATION	LOCATION	460.8644 HMA PAVEMENT 4 SMA 58-34 V TON
441+89	-	449+84	MAINLINE	236
449+84	-	494+47	MAINLINE	1328
494+47	-	517+66	MAINLINE	691
517+66	-	541+10	MAINLINE	730
541+10	-	575+00	MAINLINE	1389
575+00	-	609+00	MAINLINE	1016
609+00	-	690+54	MAINLINE	2444
690+54	-	748+00	MAINLINE	1716
748+00	-	772+52	MAINLINE	731
772+52	-	831+81	MAINLINE	1765
831+81	-	868+64	MAINLINE	1095
868+64	-	908+00	MAINLINE	1167
908+00	-	939+50.84	MAINLINE	940
			TOTAL 0010	15,247

465.0105 ASPHALTIC SURFACE

STATION	LOCATION	465.0105 ASPHALTIC SURFACE TON
462+73	LT/RT	47
470+77	LT/RT	22
478+05	LT/RT	23
510+05	LT/RT	13
568+00	LT/RT	8
617+30	LT/RT	20
687+35	LT/RT	23
708+10	LT/RT	23
743+80	LT/RT	48
769+90	RT	19
777+30	RT	19
815+25	LT	25
842+30	LT	11
850+60	RT	20
TOTAL 0010		321

465.0110 ASPHALTIC SURFACE PATCHING

LOCATION	465.0110 ASPHALTIC SURFACE PATCHING TON
PROJECT	50
TOTAL 0010	50

465.0120 ASPHALTIC SURFACE DRIVEWAYS AND FIELD ENTRANCES

STATION	LOCATION	465.0120 ASPHALTIC SURFACE DRIVEWAYS AND FIELD ENTRANCES TON
451+25	LT	3
494+27	RT	8
563+28	LT	9
567+29	LT	11
765+90	RT	14
831+30	RT	5
834+97	LT	4
838+05	LT	4
868+18	RT	4
TOTAL 0010		62

465.0425 ASPHALTIC SHOULDER RUMBLE STRIPS 2-LANE RURAL

STATION	TO	STATION	LOCATION	465.0425 ASPHALTIC SHOULDER RUMBLE STRIPS 2- LANE RURAL LF
441+89	-	770+00	LT/RT	65,622
TOTAL 0010				65,622

465.0475 ASPHALT CENTERLINE RUMBLE STRIPS 2-LANE RURAL

STATION	TO	STATION	LOCATION	465.0475 ASPHALT CENTERLINE RUMBLE STRIPS 2- LANE RURAL LF
441+89	-	924+70	CENTERLINE	48,281
TOTAL 0010				48,281

520.8000 CONCRETE COLLARS FOR PIPE

STATION	LOCATION	520.8000 CONCRETE COLLARS FOR PIPE EACH
565+10	RT	1
568+60	RT	1
TOTAL 0010		2

520.8700 CLEANING CULVERT PIPES

STATION	LOCATION	520.8700 CLEANING CULVERT PIPES EACH
565+10	RT<	1
842+30	RT<	1
878+90	RT<	1
891+10	RT<	1
TOTAL 0010		4

522.0124 CULVERT PIPE REINFORCED CONCRETE CLASS III 24-INCH

STATION	LOCATION	522.0124 CULVERT PIPE REINFORCED CONCRETE CLASS III 24-INCH LF
470+77	RT<	64
TOTAL 0010		64

522.0136 CULVERT PIPE REINFORCED CONCRETE CLASS III 36-INCH

STATION	LOCATION	522.0136 CULVERT PIPE REINFORCED CONCRETE CLASS III 36-INCH LF
708+10	RT<	58
850+60	RT<	94
TOTAL 0010		152

522.1030 APRON ENDWALLS FOR CULVERT PIPE REINFORCED CONCRETE 30-INCH

STATION	LOCATION	522.1030 APRON ENDWALLS FOR CULVERT PIPE REINFORCED CONCRETE 30- INCH EACH
462+73	RT<	2
478+05	RT<	2
565+10	LT	1
645+50	RT<	1
687+35	RT<	2
743+80	RT<	2
850+60	RT	1
TOTAL 0010		11

522.0130 CULVERT PIPE REINFORCED CONCRETE CLASS III 30-INCH

STATION	LOCATION	522.0130 CULVERT PIPE REINFORCED CONCRETE CLASS III 30-INCH LF
462+73	RT<	86
478+05	RT<	58
565+10	RT	8
568+60	RT	4
687+35	RT<	52
743+80	RT<	58
TOTAL 0010		266

522.1024 APRON ENDWALLS FOR CULVERT PIPE REINFORCED CONCRETE 24-INCH

STATION	LOCATION	522.1024 APRON ENDWALLS FOR CULVERT PIPE REINFORCED CONCRETE 24- INCH EACH
470+77	RT<	2
769+90	LT	1
777+30	LT	1
815+25	RT	1
TOTAL 0010		5

522.1036 APRON ENDWALLS FOR CULVERT PIPE REINFORCED CONCRETE 36-INCH

STATION	LOCATION	522.1036 APRON ENDWALLS FOR CULVERT PIPE REINFORCED CONCRETE 36- INCH EACH
708+10	RT<	2
783+10	RT	1
850+60	RT<	2
TOTAL 0010		5

618.0100.01 MAINTENANCE AND REPAIR OF HAUL ROADS (1180-44-70)

LOCATION	618.0100.01 MAINTENANCE AND REPAIR OF HAUL ROADS (1180-44-70) EACH
PROJECT	1
TOTAL 0010	1

619.1000 MOBILIZATION

LOCATION	619.1000 MOBILIZATION EACH
PROJECT	1.0
TOTAL 0010	1

606.0300 RIPRAP HEAVY

STATION	TO	STATION	LOCATION	606.0300 RIPRAP HEAVY CY
840+54	-	842+77	RT	255
TOTAL 0010				255

LOCATION	624.0100 WATER MGAL
PROJECT	112

625.0100 TOPSOIL

CATEGORY	STATION	TO	STATION	LOCATION	625.0100 TOPSOIL SY
0010	462+44	-	463+15	LT/RT	253
0010	470+50	-	471+10	LT/RT	130
0010	477+75	-	478+35	LT/RT	177
0010	509+95	-	510+25	LT/RT	28
0010	519+95	-	520+40	LT/RT	49
0010	544+80	-	565+65	RT	1,432
0010	565+85	-	567+85	RT	135
0010	568+05	-	575+25	RT	650
0010	617+05	-	617+55	LT/RT	111
0010	623+10	-	623+40	LT/RT	52
0010	645+40	-	645+60	LT	100
0010	687+15	-	687+75	LT/RT	118
0010	707+80	-	708+40	LT/RT	141
0010	743+50	-	743+15	LT/RT	142
0010	754+40	-	754+60	LT	11
0010	769+55	-	770+10	RT	118
0010	776+90	-	777+80	RT	170
0010	782+80	-	783+15	RT	11
0010	814+85	-	815+65	LT	143
0010	840+50	-	843+00	RT	1,423
0010	842+15	-	842+65	LT	82
0010	850+10	-	850+50	RT	183
TOTAL					5659

625.0500 SALVAGED TOPSOIL

STATION	TO	STATION	LOCATION	625.0500 SALVAGED TOPSOIL SY
544+80	-	575+25	RT	3,000
TOTAL 0010				3,000

628.1504 SILT FENCE

STATION	TO	STATION	LOCATION	628.1504 SILT FENCE LF
462+44	-	463+15	LT/RT	135
470+50	-	471+10	LT/RT	120
477+75	-	478+35	LT/RT	120
509+95	-	510+25	LT/RT	70
519+95	-	520+40	LT/RT	85
544+80	-	565+65	RT	2,076
565+85	-	567+85	RT	190
568+05	-	575+25	RT	709
617+05	-	617+55	LT/RT	90
623+10	-	623+40	LT/RT	60
645+40	-	645+60	LT	20
687+15	-	687+75	LT/RT	135
707+80	-	708+40	LT/RT	120
743+50	-	743+15	LT/RT	130
754+40	-	754+60	LT	20
769+55	-	770+10	RT	65
776+90	-	777+80	RT	100
782+80	-	783+15	RT	40
814+85	-	815+65	LT	85
842+15	-	842+65	LT	50
850+10	-	850+50	RT	50
TOTAL 0010				4,470

628.1520 SILT FENCE MAINTENANCE

STATION	TO	STATION	LOCATION	628.1520 SILT FENCE MAINTENANCE LF
462+44	-	463+15	LT/RT	135
470+50	-	471+10	LT/RT	120
477+75	-	478+35	LT/RT	120
509+95	-	510+25	LT/RT	70
519+95	-	520+40	LT/RT	85
544+80	-	565+65	RT	2,076
565+85	-	567+85	RT	190
568+05	-	575+25	RT	709
617+05	-	617+55	LT/RT	90
623+10	-	623+40	LT/RT	60
645+40	-	645+60	LT	20
687+15	-	687+75	LT/RT	135
707+80	-	708+40	LT/RT	120
743+50	-	743+15	LT/RT	130
754+40	-	754+60	LT	20
769+55	-	770+10	RT	65
776+90	-	777+80	RT	100
782+80	-	783+15	RT	40
814+85	-	815+65	LT	85
842+15	-	842+65	LT	50
850+10	-	850+50	RT	50
TOTAL 0010				4,470

628.1905 MOBILIZATIONS EROSION CONTROL

LOCATION	628.1905 MOBILIZATIONS EROSION CONTROL EACH
PROJECT	2
TOTAL 0010	2

628.1910 MOBILIZATIONS EMERGENCY EROSION CONTROL

LOCATION	628.1910 MOBILIZATIONS EMERGENCY EROSION CONTROL EACH
PROJECT	2
TOTAL 0010	2

628.2008 EROSION MAT URBAN CLASS 1 TYPE B

LOCATION	628.2008 EROSION MAT URBAN CLASS I TYPE B SY
PROJECT	3,000
TOTAL 0010	3,000

628.2004 EROSION MAT CLASS 1 TYPE B

STATION	TO	STATION	LOCATION	628.2004 EROSION MAT CLASS I TYPE B SY
462+44	-	463+15	LT/RT	253
470+50	-	471+10	LT/RT	130
477+75	-	478+35	LT/RT	177
509+95	-	510+25	LT/RT	28
519+95	-	520+40	LT/RT	49
544+80	-	565+65	RT	3,412
565+85	-	567+85	RT	337
568+05	-	575+25	RT	1,467
617+05	-	617+55	LT/RT	111
623+10	-	623+40	LT/RT	52
645+40	-	645+60	LT	100
687+15	-	687+75	LT/RT	118
707+80	-	708+40	LT/RT	141
743+50	-	743+15	LT/RT	142
754+40	-	754+60	LT	11
769+55	-	770+10	RT	118
776+90	-	777+80	RT	170
782+80	-	783+15	RT	11
814+85	-	815+65	LT	143
840+50	-	843+00	RT	1,423
842+15	-	842+65	LT	82
850+10	-	850+50	RT	183
			TOTAL 0010	8,659

628.7555 CULVERT PIPE CHECKS

629.0210 FERTILIZER TYPE B

628.7555
CULVERT PIPE
CHECKS
EACH

629.0210
FERTILIZER TYPE B
CWT

STATION	LOCATION	628.7555 CULVERT PIPE CHECKS EACH
462+73	RT<	1
470+77	RT<	1
478+05	RT<	1
510+05	RT<	1
520+10	RT<	1
565+10	RT	1
565+10	RT	1
568+60	RT<	1
568+60	RT	1
617+30	RT<	1
623+30	RT<	1
645+50	LT	1
687+35	RT<	1
708+10	RT<	1
743+80	RT<	1
754+40	LT	1
769+90	RT	1
777+30	RT	1
815+25	LT	1
842+30	LT	1
850+60	RT	1
TOTAL0010		21

STATION	TO	STATION	LOCATION	629.0210 FERTILIZER TYPE B CWT
462+44	-	463+15	LT/RT	0.16
470+50	-	471+10	LT/RT	0.08
477+75	-	478+35	LT/RT	0.11
509+95	-	510+25	LT/RT	0.02
519+95	-	520+40	LT/RT	0.03
544+80	-	565+65	RT	2.15
565+85	-	567+85	RT	0.21
568+05	-	575+25	RT	0.92
617+05	-	617+55	LT/RT	0.07
623+10	-	623+40	LT/RT	0.03
645+40	-	645+60	LT	0.06
687+15	-	687+75	LT/RT	0.07
707+80	-	708+40	LT/RT	0.09
743+50	-	743+15	LT/RT	0.09
754+40	-	754+60	LT	0.01
769+55	-	770+10	RT	0.07
776+90	-	777+80	RT	0.11
782+80	-	783+15	RT	0.01
814+85	-	815+65	LT	0.09
840+50	-	843+00	RT	0.90
842+15	-	842+65	LT	0.05
850+10	-	850+50	RT	0.12
				5.45

3

3

630.0175 SEEDING MIXTURE NO. 75

STATION	LOCATION	630.0175 SEEDING MIXTURE NO. 75 LB
463+15	LT/RT	2
471+10	LT/RT	1
478+35	LT/RT	1
510+25	LT/RT	0
520+40	LT/RT	0
565+65	RT	21
567+85	RT	2
575+25	RT	9
617+55	LT/RT	1
623+40	LT/RT	0
645+60	LT	1
687+75	LT/RT	1
708+40	LT/RT	1
743+15	LT/RT	1
754+60	LT	0
770+10	RT	1
777+80	RT	1
783+15	RT	0
815+65	LT	1
843+00	RT	9
842+65	LT	1
850+50	RT	1
TOTAL 0010		55

633.5200 MARKERS CULVERT END

LOCATION	633.5200 MARKERS CULVERT END EACH
PROJECT	55
TOTAL 0010	55

638-SIGNS

SIGN GROUP #	SIGN CODE	SIGN MESSAGE	SIZE (INCHES)	638-SIGNS							REMARKS
				634.0616 POSTS WOOD 4X6- INCH X 16-FT EACH	637.2210 SIGNS TYPE II REFLECTIVE H SF	637.2230 SIGNS TYPE II REFLECTIVE F SF	638.2102 MOVING SIGNS TYPE II EACH	638.2602 REMOVING SIGNS TYPE II EACH	638.3000 REMOVING SMALL SIGN SUPPORTS EACH	638.4000 MOVING SMALL SIGN SUPPORTS EACH	
PROJECT 1180-44-70											
A-1	R2-1	SPEED LIMIT 55 MPH	24 X 30	-	-	-	-	-	-	-	
A-2	W2-2	SIDE ROAD (90 DEGREES)	30 X 30	-	-	-	1	-	-	1	
A-3	W13-1	ADVISORY SPEED PLATE (YELLOW BACK)	18 X 18	-	-	-	1	-	-	-	
	R3-50L	LANE CONTROL SYMBOL -LEFT ONLY	30 X 36	1	8	-	-	-	-	-	
A-4	R3-50A	ARROW UP/ONLY	30 X 36	1	8	-	-	-	-	-	
	R2-1	SPEED LIMIT 50 MPH	24 X 30	-	-	-	1	-	-	1	
B-1	R3-7R	RIGHT LANE MUST TURN RIGHT	30 X 30	1	6	-	-	-	-	-	
B-2	R3-50A	ARROW UP/ONLY	30 X 36	1	8	-	-	-	-	-	
	R3-50R	LANE CONTROL SYMBOL - RIGHT ONLY	30 X 36	1	8	-	-	-	-	-	
B-3	W2-2	SIDE ROAD (90 DEGREES)	30 X 30	-	-	-	-	-	-	-	TO REMAIN
	W13-1	ADVISORY SPEED PLATE (YELLOW BACK)	18 X 18	-	-	-	-	-	-	-	TO REMAIN
B-4	R3-7R	RIGHT LANE MUST TURN RIGHT	30 X 30	1	6	-	-	-	-	-	
B-5	W11-2	PEDESTRIAN CROSSING SYMBOL	36 X 36	-	-	-	-	-	-	-	
	W16-9P	AHEAD PLAQUE (YELLOW)	30 X 18	-	-	-	-	-	-	-	
B-6	R3-50A	ARROW UP/ONLY	30 X 36	1	8	-	-	-	-	-	
	R3-50R	LANE CONTROL SYMBOL - RIGHT ONLY	30 X 36	1	8	-	-	-	-	-	
B-7	R2-1	SPEED LIMIT 50 MPH	24 X 30	-	-	-	-	-	-	-	TO REMAIN
	R9-1	WALK ON LEFT SIDE FACING TRAFFIC	18 X 24	-	-	-	-	-	-	-	TO REMAIN
B-8	W9-1-R	RIGHT LANE ENDS	36 X 36	-	-	-	-	1	1	-	
B-9	R3-50L	LANE CONTROL SYMBOL -LEFT ONLY	30 X 36	1	8	-	-	-	-	-	
	R3-50A	ARROW UP/ONLY	30 X 36	1	8	-	-	-	-	-	
B-10	W9-2-L	LANE ENDS MERGE LEFT	36 X 36	-	-	-	-	1	1	-	
B-11	R2-1	SPEED LIMIT 50 MPH	24 X 30	-	-	-	1	-	-	1	
B-12	R3-50L	LANE CONTROL SYMBOL -LEFT ONLY	30 X 36	1	8	-	-	-	-	-	
	R3-50A	ARROW UP/ONLY	30 X 36	1	8	-	-	-	-	-	
C-1	R2-1	SPEED LIMIT 50 MPH	24 X 30	-	-	-	-	-	-	-	TO REMAIN
	R9-1	WALK ON LEFT SIDE FACING TRAFFIC	18 X 24	-	-	-	-	-	-	-	TO REMAIN
C-2	R3-50A	ARROW UP/ONLY	30 X 36	1	8	-	-	-	-	-	
	R3-50R	LANE CONTROL SYMBOL - RIGHT ONLY	30 X 36	1	8	-	-	-	-	-	
C-3	R3-20R	BEGIN RIGHT TURN LANE WITH DOWN LEFT ARROW	24 X 36	1	6	-	-	-	-	-	
C-4	WO6-3	TWO WAY TRAFFIC SYMBOL	48 X 48	1	-	16	-	-	-	-	
TOTAL0010				16	113	16	4	2	2	3	

642.5001 FIELD OFFICE TYPE B

LOCATION	642.5001 FIELD OFFICE TYPE B EACH
PROJECT	1
TOTAL 0010	1

643.0300 TRAFFIC CONTROL DRUMS

STATION	TO	STATION	LOCATION	643.0300 TRAFFIC CONTROL DRUMS DAY	REMARKS
542+10	-	574+95	RT	1,960	CASINO
		VARIES		120	CULVERT WORK
			TOTAL 0010	2,080	

643.0900 TRAFFIC CONTROL SIGNS

STATION	TO	STATION	LOCATION	643.0900 TRAFFIC CONTROL SIGNS DAY
441+89	-	924+70	PROJECT	2,520
			TOTAL 0010	2,520

643.0715 TRAFFIC CONTROL WARNING LIGHTS TYPE C

STATION	TO	STATION	LOCATION	643.0715 TRAFFIC CONTROL WARNING LIGHTS TYPE C DAY
542+10	-	574+95	RT	300
			TOTAL 0010	300

643.5000 TRAFFIC CONTROL

LOCATION	643.5000 TRAFFIC CONTROL EACH
PROJECT	1
TOTAL 0010	1

645.0120 GEOTEXTILE TYPE HR

STATION	TO	STATION	LOCATION	645.0120 GEOTEXTILE TYPE HR SY
540+54	-	542+77	RT	2,300
			TOTAL 0010	2,300

646.1020 MARKING LINE EPOXY 4-INCH

646.1020 MARKING LINE EPOXY 4-INCH					
STATION	TO	STATION	LOCATION	646.1020 MARKING LINE EPOXY 4-INCH LF	REMARKS
441+89	-	924+70	EDGELINES	99623	WHITE EDGELINE
441+89	-	924+70	CL	58,976	YELLOW CL
441+89	-	924+70	PASSING & TURN LANES	1,581	DASHED WHITE
TOTAL 0010				160,180	

646.1040 MARKING LINE GROOVED WET REF EPOXY 4-INCH

646.1040 MARKING LINE GROOVED WET REF EPOXY 4-INCH					
STATION	TO	STATION	LOCATION	646.1040 MARKING LINE GROOVED WET REF EPOXY 4-INCH LF	REMARKS
441+89	-	924+70	EDGELINES	99623	WHITE EDGELINE
TOTAL 0010				99,623	

646.3040 MARKING LINE GROOVED WET REF EPOXY 8-INCH

646.3040 MARKING LINE GROOVED WET REF EPOXY 8-INCH					
STATION	TO	STATION	LOCATION	646.3040 MARKING LINE GROOVED WET REF EPOXY 8-INCH LF	REMARKS
551+30	-	554+30	TURN LANE	300	
555+15	-	559+15	TURN LANE	400	
558+90	-	562+90	TURN LANE	400	
563+70	-	566+85	TURN LANE	315	
565+35	-	566+85	TURN LANE	150	
567+75	-	571+45	TURN LANE	370	
766+50	-	767+29	TURN LANE	77	
768+90	-	770+47	TURN LANE	157	
909+80	-	911+06	TURN LANE	226	
TOTAL 0010				2,395	

646.4520 MARKING LINE SAME DAY EPOXY 4-INCH

STATION	TO	STATION	LOCATION	646.4520 MARKING LINE SAME DAY EPOXY 4-INCH LF
441+89	-	924+70	CL	47,887
TOTAL 0010				47,887

646.5020 MARKING ARROW EPOXY

STATION	LOCATION	646.5020 MARKING ARROW EPOXY EACH
551+55	LEFT TURN LANE	1
553+90	LEFT TURN LANE	1
559+15	LEFT TURN LANE	1
562+45	LEFT TURN LANE	1
566+75	LEFT TURN LANE	1
TOTAL 0010		5

646.7120 MARKING DIAGONAL EPOXY 12-INCH

STATION	TO	STATION	LOCATION	646.7120 MARKING DIAGONAL EPOXY 12-INCH LF
542+00	-	551+30	RT	170
555+14	-	558+90	RT	50
559+17	-	562+90	LT	150
563+70	-	565+36	RT	150
567+75	-	575+00	RT	230
TOTAL 0010				750

646.5120 MARKING WORD EPOXY

STATION	LOCATION	646.5120 MARKING WORD EPOXY EACH
553+45	LEFT TURN LANE	1
562+00	LEFT TURN LANE	1
TOTAL 0010		2

649.0105 TEMPORARY MARKING LINE PAINT 4-INCH

STATION	TO	STATION	LOCATION	649.0105 TEMPORARY MARKING LINE PAINT 4-INCH LF	REMARKS
441+89	-	924+70	CL	41,718	YELLOW CENTERLINE
TOTAL 0010				41,718	

650.4500 CONSTRUCTION STAKING SUBGRADE

STATION	TO	STATION	LOCATION	650.4500 CONSTRUCTION STAKING SUBGRADE LF
542+00	-	575+00		3,300
TOTAL 0010				3,300

650.5000 CONSTRUCTION STAKING BASE

STATION	TO	STATION	LOCATION	650.5000 CONSTRUCTION STAKING BASE LF
542+00	-	575+00		3,300
TOTAL 0010				3,300

650.6000
CONSTRUCTION
STAKING PIPE
CULVERTS

STATION	LOCATION	EACH	REMARKS
462+73	RT<	1	PIPE REPLACEMENT
470+77	RT<	1	PIPE REPLACEMENT
478+05	RT<	1	PIPE REPLACEMENT
687+35	RT<	1	PIPE REPLACEMENT
708+10	RT<	1	PIPE REPLACEMENT
743+80	RT<	1	PIPE REPLACEMENT
850+60	RT<	1	PIPE REPLACEMENT
TOTAL 0010		7	

650.8000 CONSTRUCTION STAKING RESURFACING REFERENCE

STATION	TO	STATION	LOCATION	650.8000 CONSTRUCTION STAKING RESURFACING REFERENCE LF
441+89	-	924+70	MAINLINE	48,281
TOTAL 0010				48,281

650.9911
CONSTRUCTION STAKING
SUPPLEMENTAL CONTROL (1180-44-
70)

LOCATION	EACH
PROJECT	1
TOTAL 0010	1

650.9920 CONSTRUCTION STAKING SLOPE STAKES

STATION	TO	STATION	LOCATION	650.9920 CONSTRUCTION STAKING SLOPE STAKES LF
542+00	-	575+00		3,300
TOTAL 0010				3,300

690.0150 SAWING ASPHALT

STATION	TO	STATION	LOCATION	690.0150 SAWING ASPHALT LF
542+00	-	575+00	RECONFIGURATION	3,286
TOTAL 0010				3,286

LOCATION	SPV.0060 DENOMIE CREEK RESTORATION EACH
PROJECT	1
TOTAL 0010	1

SPV.0060.01 RESETTING CULVERT SECTIONS

STATION	LOCATION	SPV.0060.01 RESETTING CULVERT SECTIONS EACH	REMARKS
510+05	RT<	4	2 SECTIONS & 2 AEW
520+10	RT<	3	1 SECTION & 2 AEW
565+10	RT	1	1AEW
568+60	RT<	5	3 SECTIONS & 2 AEW
617+30	RT<	5	3 SECTIONS & 2 AEW
623+30	RT<	3	1 SECTION & 2 AEW
645+50	LT	1	1 AEW
754+40	LT	1	1AEW
769+90	RT	4	3 SECTIONS & 1 AEW
777+30	RT	4	3 SECTIONS & 1 AEW
815+25	LT	5	4 SECTIONS & 1 AEW
842+30	LT	5	4 SECTIONS & 1 AEW
850+60	RT	4	3 SECTIONS & 1 AEW
TOTAL 0010		45	

HMA / SMA Acceptance Table

HMA / SMA Acceptance Table							Quality Management program to be used	
Location	Station	Mixture Use	Underlying Surface	Bid Item	Tons	Thickness	Mixture Acceptance	Density Acceptance
12' Driving Lane		Upper Layer	Milled Surface	460.8644	15247	2"	QMP as per SS 460	Incentive Density HMA Pavement (460.2000)
Shoulders, sideroads, Turn lanes	Various	Upper Layer	Milled Surface	460.6244	9319	2"	QMP as per SS 460	Accepted by Department Testing, Not Eligible for Incentive
Driveways	Various	Upper Layer	Milled surface/ Base aggregate	Asphaltic Surface Driveways	62	2"	QMP as per SS 460	Accepted by Ordinary Compaction
Culvert Patches	Various	Lower and Upper	Base Aggregate	Asphaltic Surface	321	6"	QMP as per SS 460	Accepted by Ordinary Compaction
Patching	Various	Lower	Milled Surface	Asphaltic Surface Patching	50	Varies	QMP as per SS 460	Accepted by Ordinary Compaction

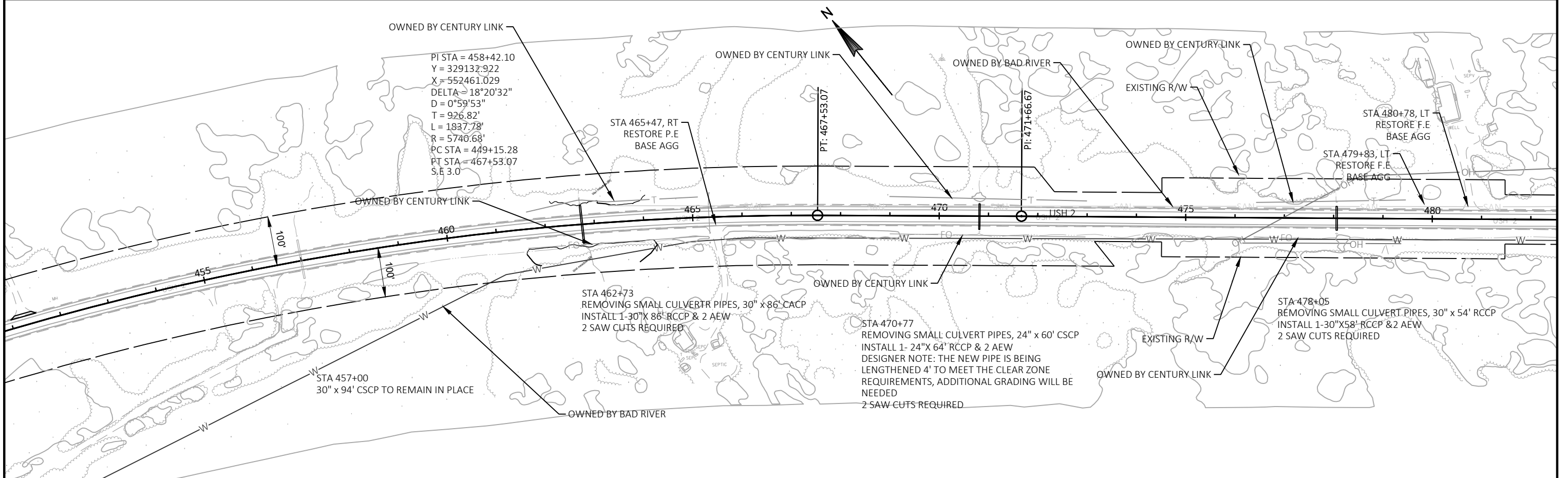
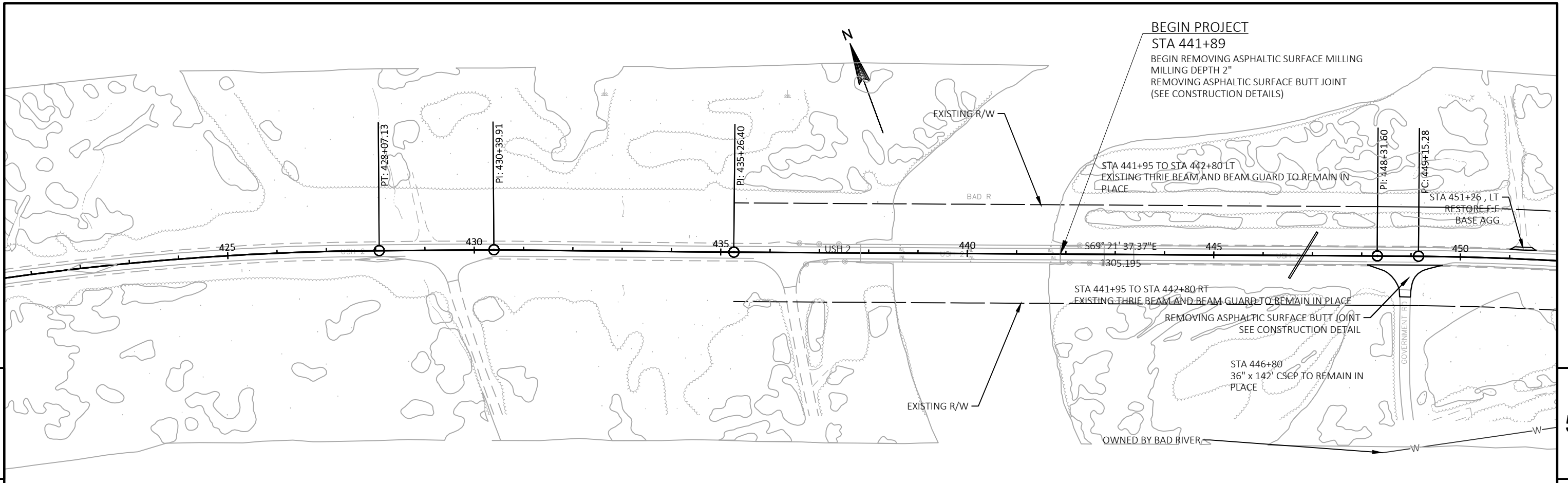

PROJECT NO: 1180-44-70	HWY: USH 2	COUNTY: ASHLAND & IRON	PLAN SHEETS	SHEET	E
------------------------	------------	------------------------	-------------	-------	---

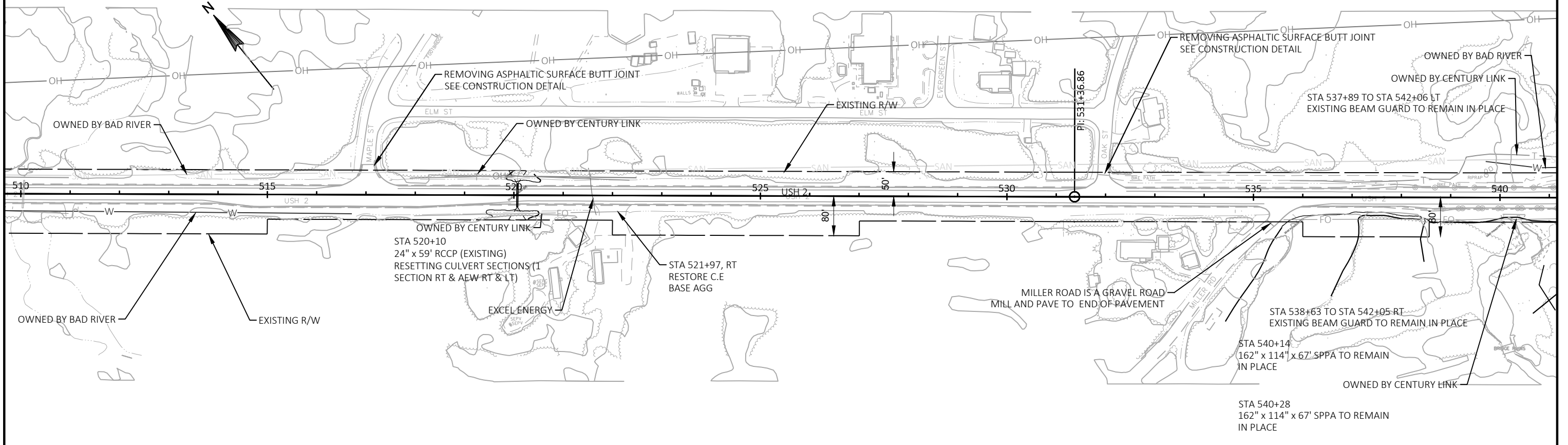
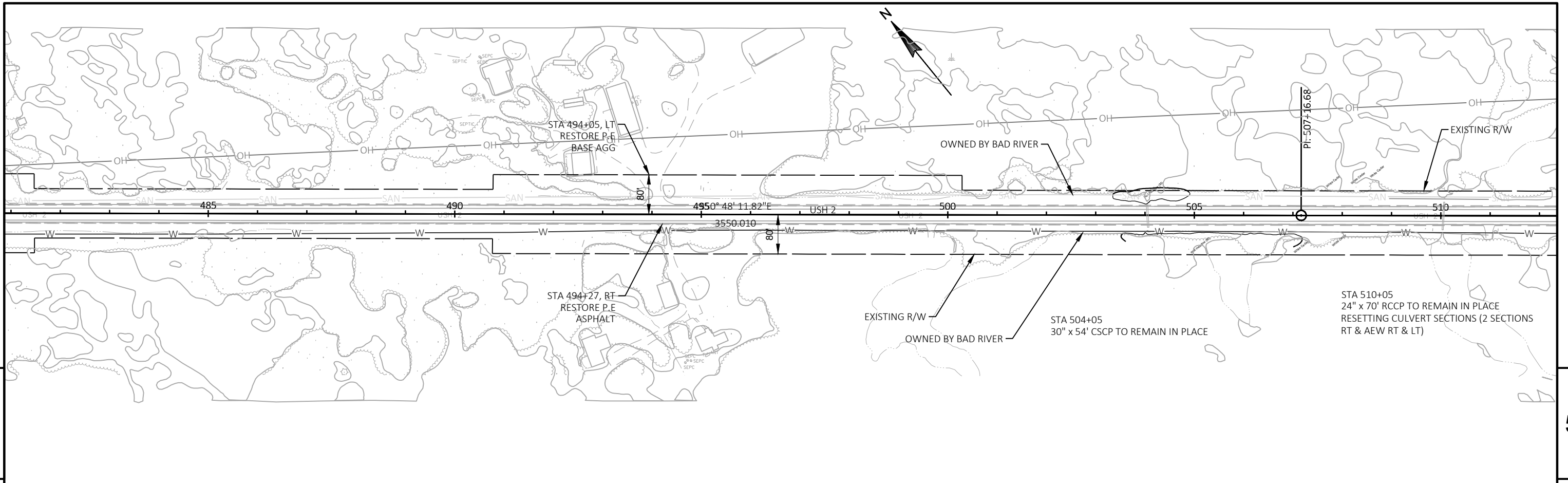

PROJECT NO: 1180-44-70	HWY: USH 2	COUNTY: ASHLAND & IRON	PLAN SHEETS	SHEET	E
------------------------	------------	------------------------	-------------	-------	---

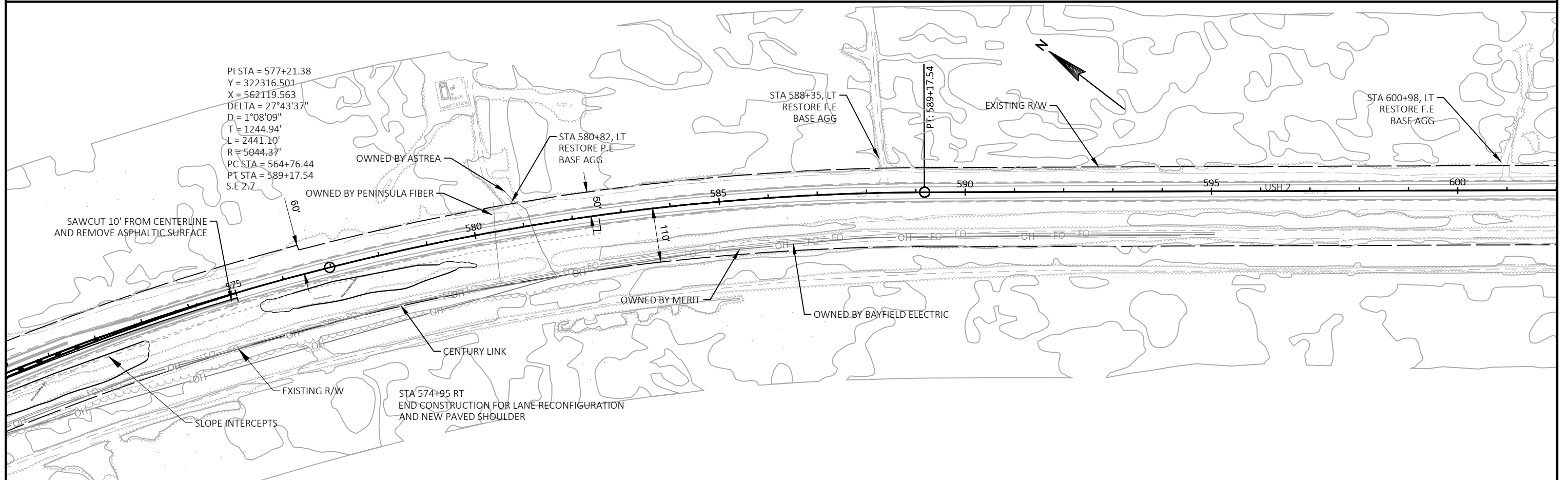
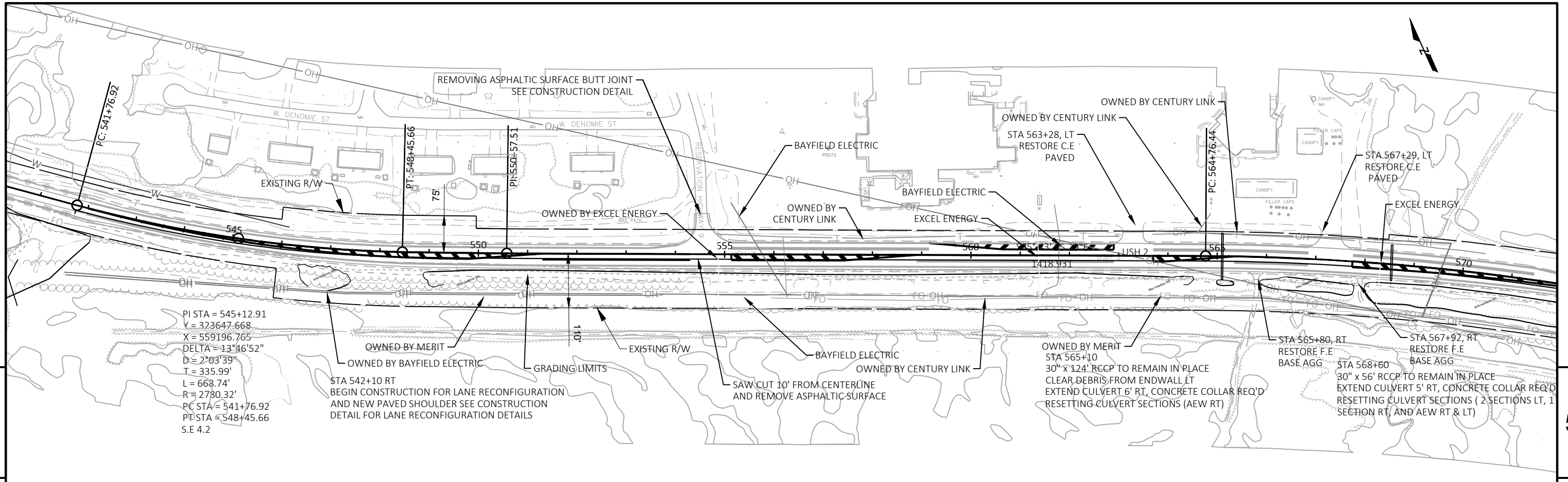

PROJECT NO: 1180-44-70	HWY: USH 2	COUNTY: ASHLAND & IRON	PLAN SHEETS	SHEET	E
------------------------	------------	------------------------	-------------	-------	---

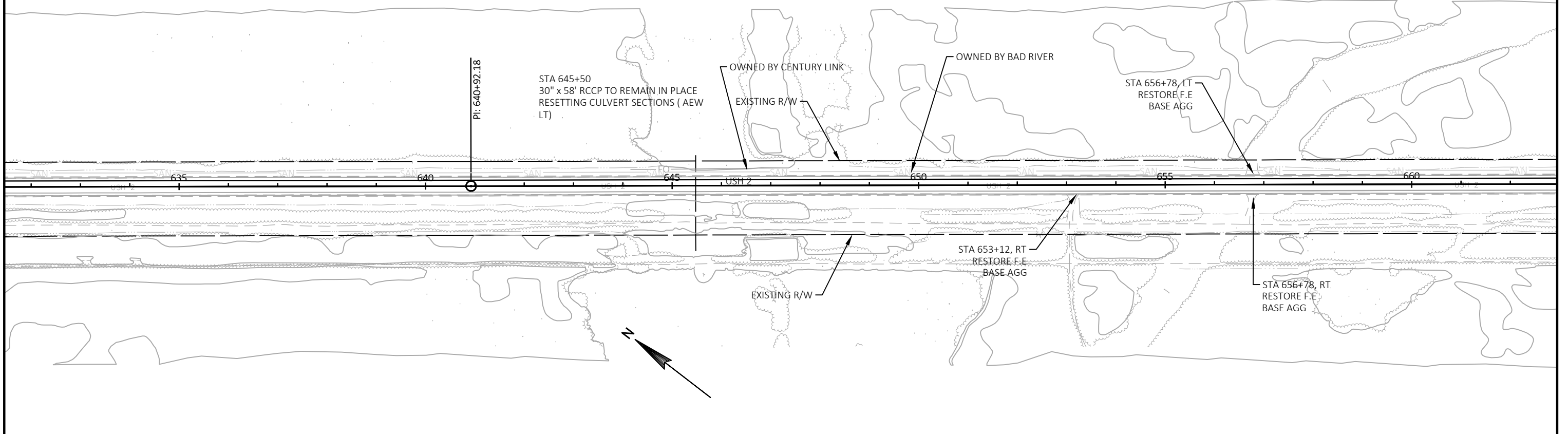
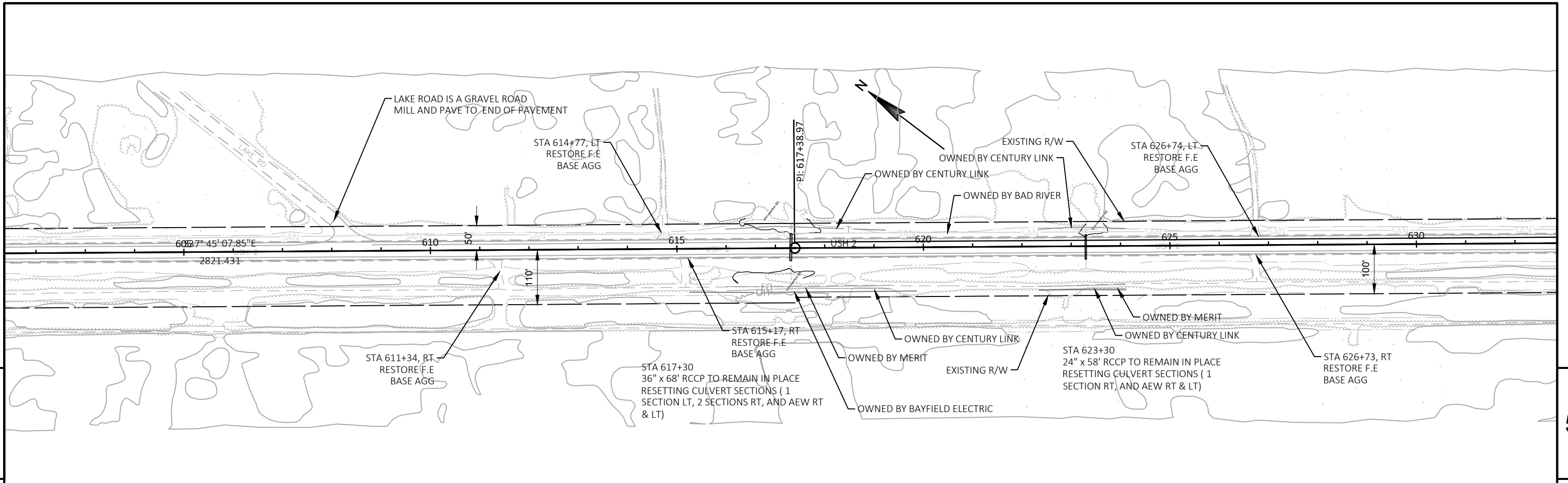

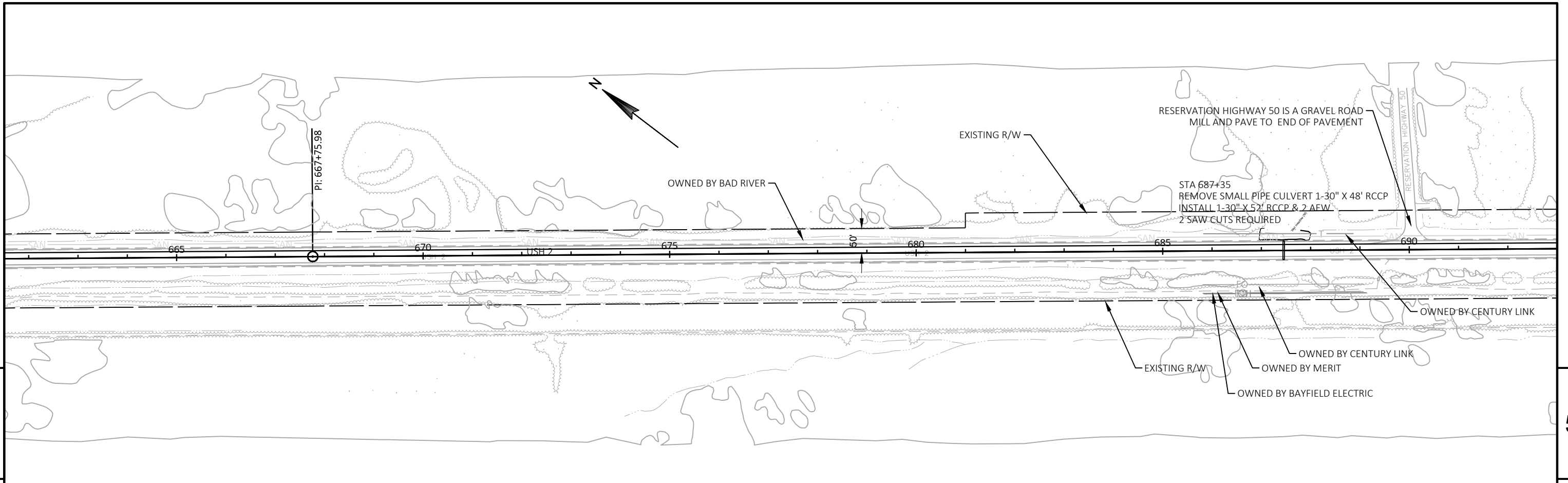

5

5

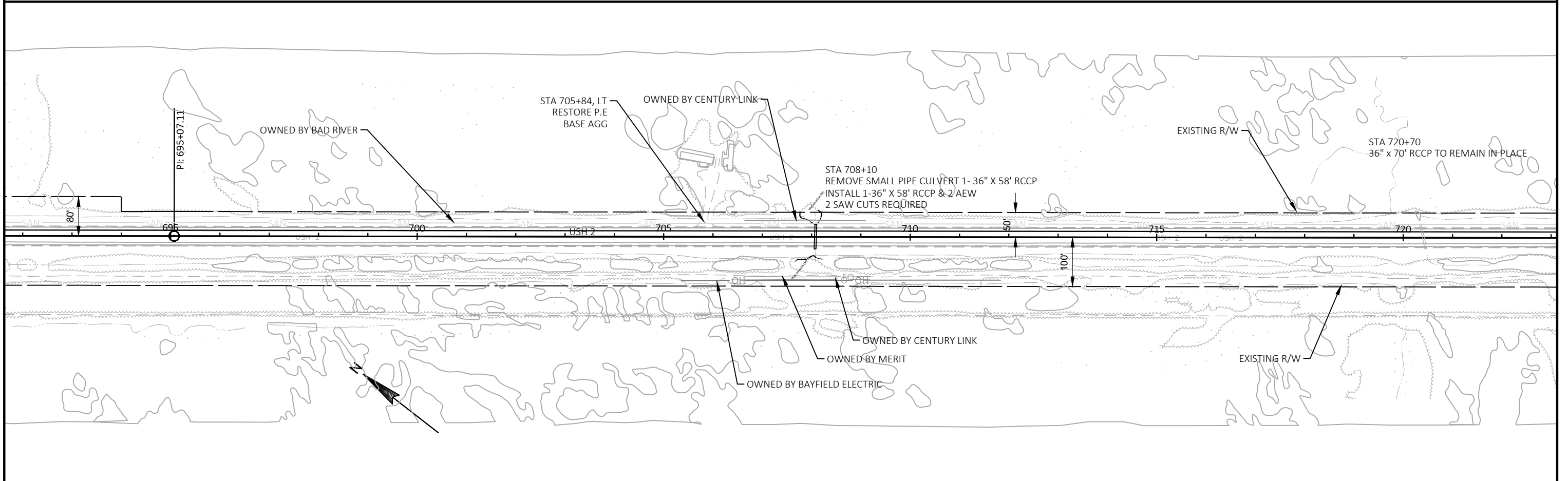

PROJECT NO: 1180-44-70	HWY: USH 2	COUNTY: ASHLAND & IRON	PLAN SHEETS	SHEET	E
------------------------	------------	------------------------	-------------	-------	---

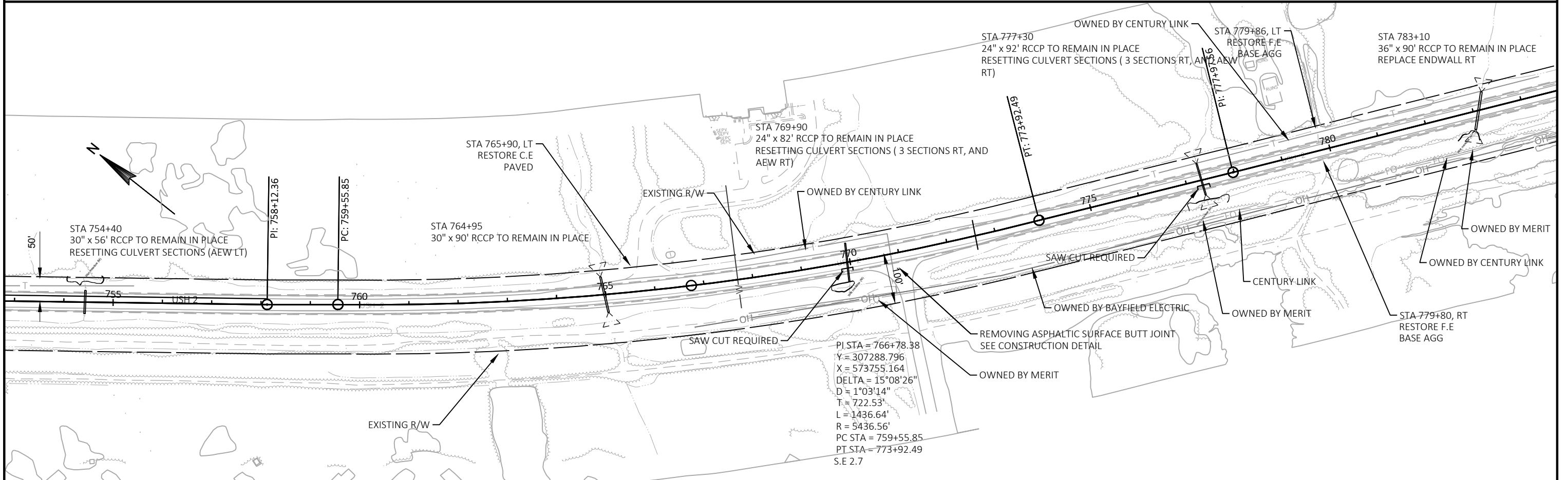
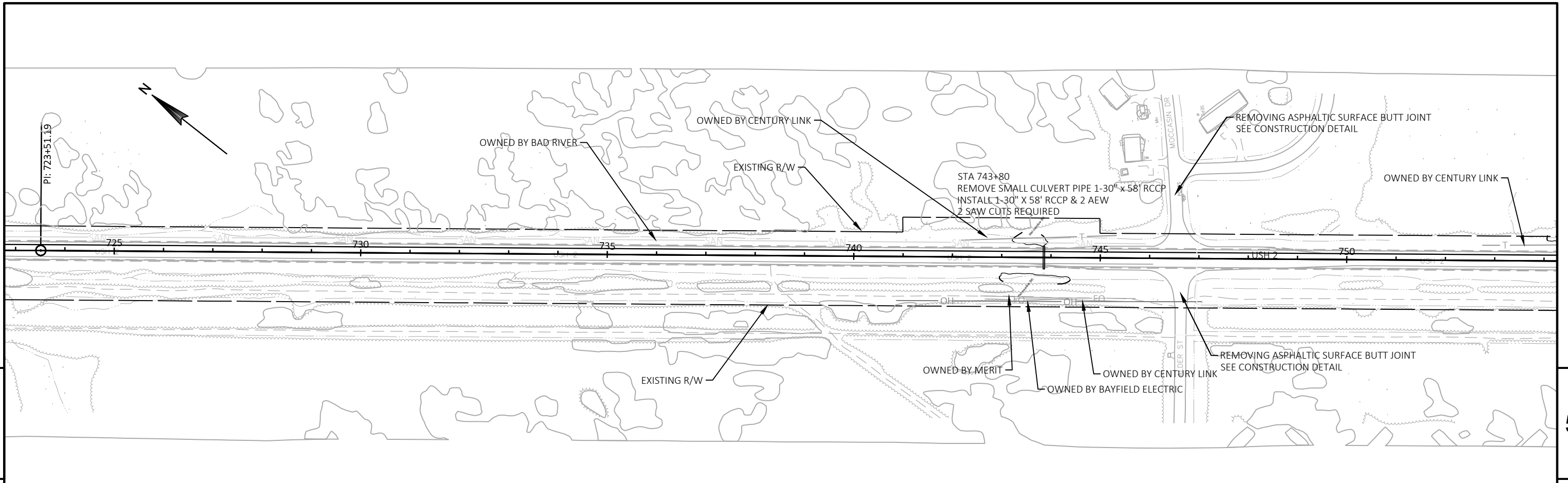

PROJECT NO: 1180-44-70	HWY: USH 2	COUNTY: ASHLAND & IRON	PLAN SHEETS	SHEET	E
------------------------	------------	------------------------	-------------	-------	---

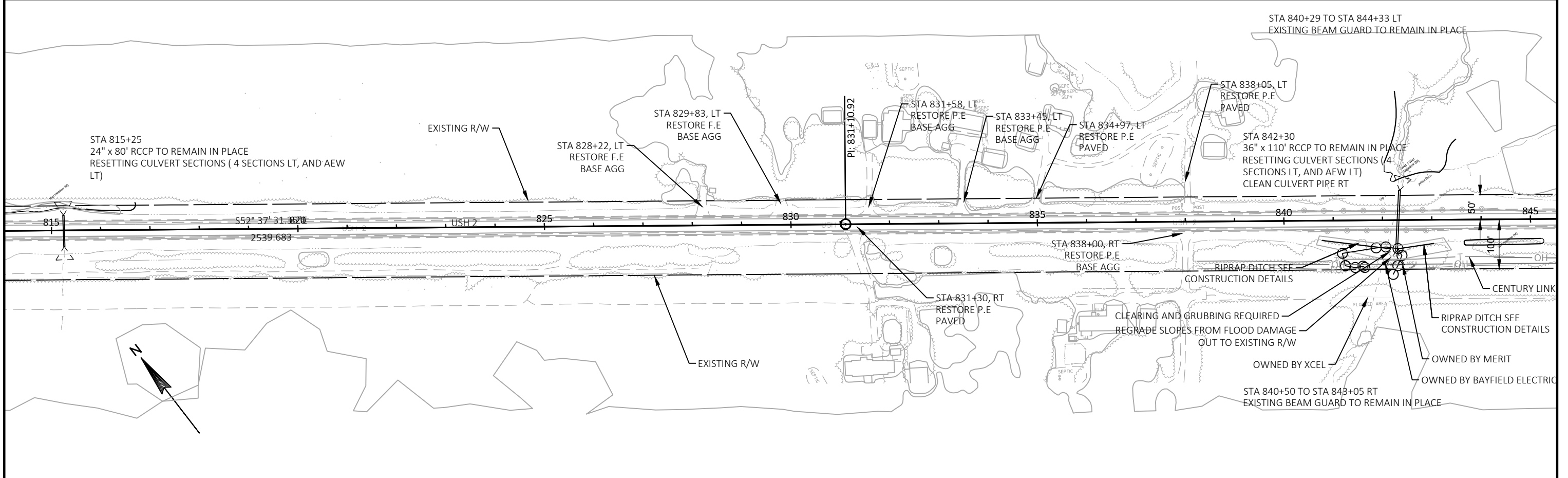
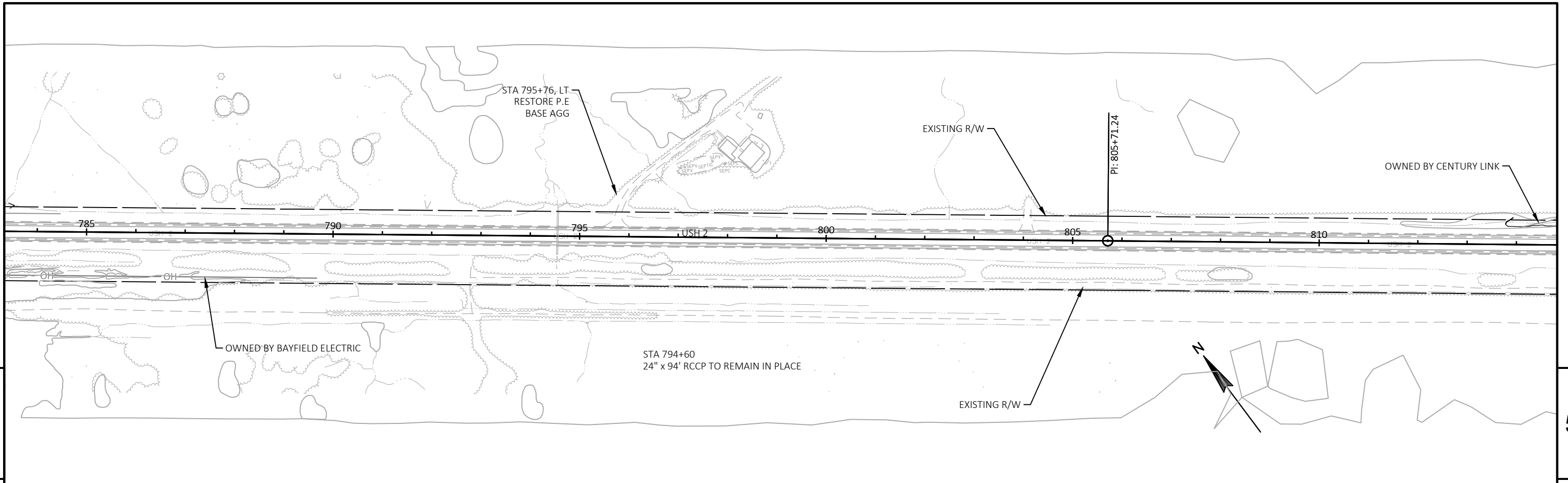

PROJECT NO: 1180-44-70	HWY: USH 2	COUNTY: ASHLAND & IRON	PLAN SHEETS	SHEET	E
------------------------	------------	------------------------	-------------	-------	----------

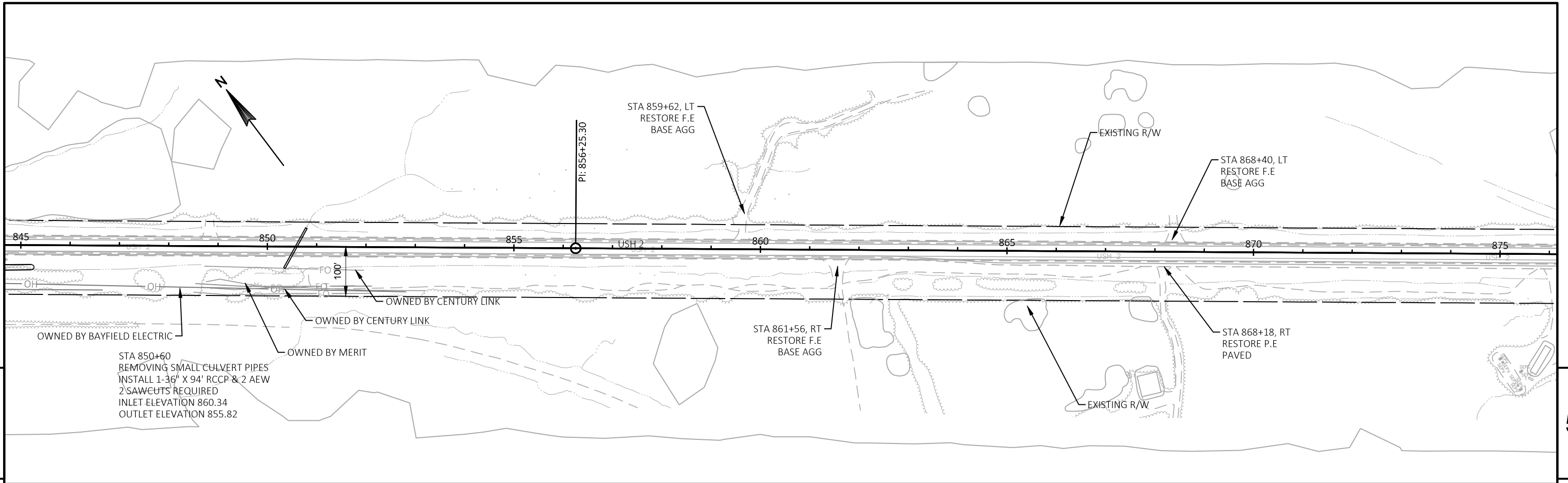

5

5

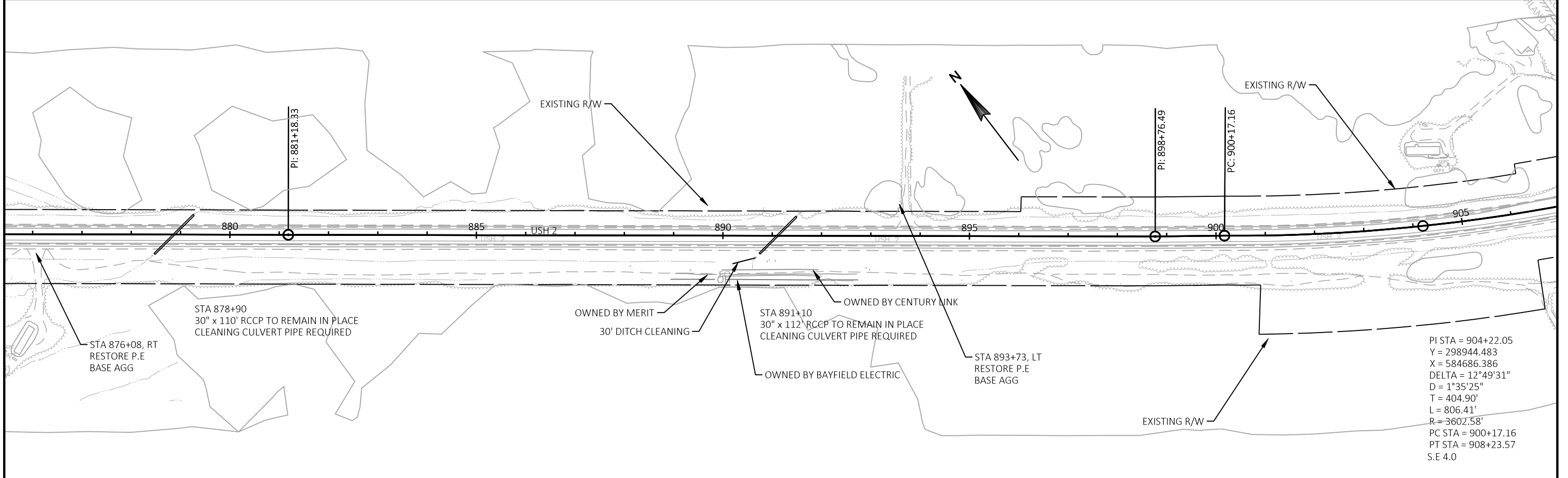

PROJECT NO: 1180-44-70	HWY: USH 2	COUNTY: ASHLAND & IRON	PLAN SHEETS	SHEET	E
------------------------	------------	------------------------	-------------	-------	----------

FILE NAME : N:\PDS\C3D\11804401\SHEETSPLAN\050400_PLN.DWG PLOT DATE : 9/26/2022 2:47 PM PLOT BY : FINNEGAN, MITCHELL PLOT NAME : PLOT SCALE : 1 IN:200 FT WISDOT/CADD'S SHEET 44

PI STA = 904+22.05
 Y = 298944.483
 X = 584686.386
 DELTA = 12°49'31"
 D = 1°35'25"
 T = 404.90'
 L = 806.41'
 R = 3602.58'
 PC STA = 900+17.16
 PT STA = 908+23.57
 S.E 4.0

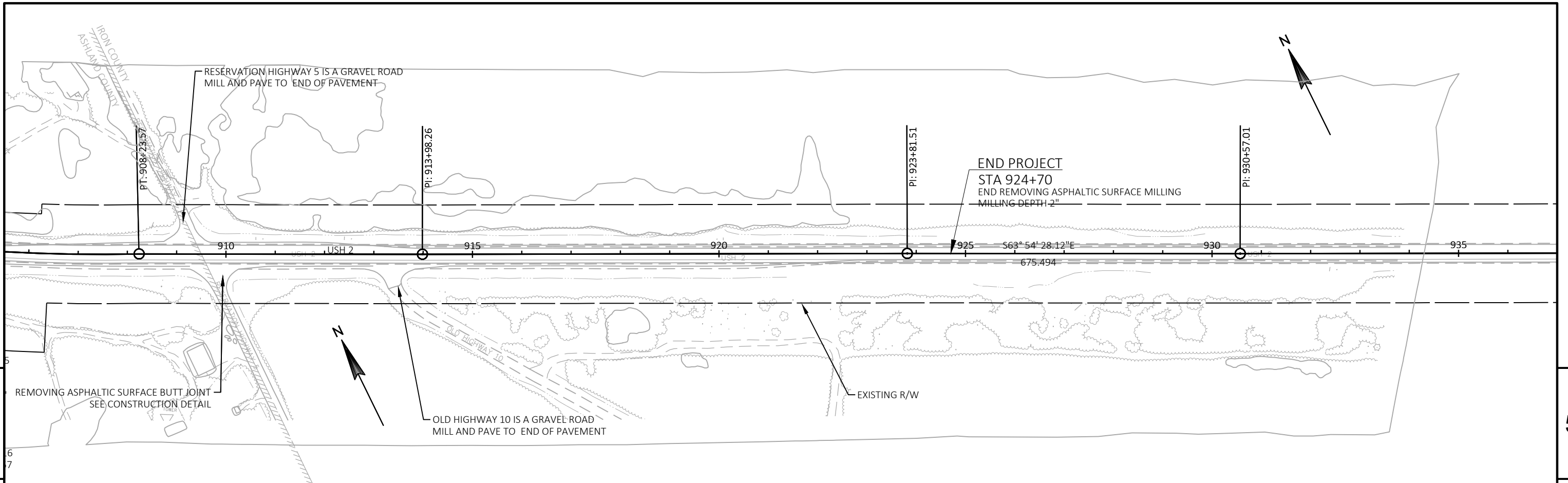

PROJECT NO: 1180-44-70

HWY: USH 2

COUNTY: ASHLAND & IRON

PLAN SHEETS

SHEET

E

Standard Detail Drawing List

08E09-06	SILT FENCE
08E15-01	CULVERT PIPE CHECK
08F01-11	APRON ENDWALLS FOR CULVERT PIPE
08F04-08	JOINT TIES FOR CONCRETE PIPE AND CONCRETE COLLAR DETAIL
13A10-02A	2-LANE RURAL SHOULDER RUMBLE STRIP, MILLING
13A10-02B	2-LANE RURAL SHOULDER RUMBLE STRIP, MILLING
13A10-02C	2-LANE RURAL SHOULDER RUMBLE STRIP, MILLING
13A10-02D	2-LANE RURAL SHOULDER RUMBLE STRIP, MILLING
13A11-03A	2-LANE RURAL CENTER LINE RUMBLE STRIP, MILLING
13A11-03B	2-LANE RURAL CENTER LINE RUMBLE STRIP, MILLING
13C19-03	HMA LONGITUDINAL JOINTS
14B29-01	SAFETY EDGE
15A03-02A	FLEXIBLE MARKER POST FOR CULVERT END
15A03-02B	FLEXIBLE MARKER POST FOR CULVERT END
15C04-05	TRAFFIC CONTROL, ADVANCE WARNING SIGNS 45 M. P. H. OR GREATER TWO-WAY UNDIVIDED ROAD OPEN TO TRAFFIC
15C07-15A	PAVEMENT MARKING SYMBOLS
15C07-15B	PAVEMENT MARKING WORDS
15C07-15C	PAVEMENT MARKING ARROWS
15C08-21A	LONGITUDINAL MARKING (MAINLINE)
15C08-21B	TEMPORARY LONGITUDINAL PAVEMENT MARKING
15C08-21C	PAVEMENT MARKING (TURN LANES)
15C11-09B	CHANNELIZING DEVICES DRUMS, CONES, BARRICADES AND VERTICAL PANELS
15C12-09A	TRAFFIC CONTROL FOR LANE CLOSURE WITH FLAGGING OPERATION
15C18-06A	MEDIAN ISLAND MARKING PAVEMENT MARKINGS
15C19-07A	MOVING PAVEMENT MARKING OPERATION TWO-LANE TWO-WAY ROADWAY
15C35-05A	PAVEMENT MARKING (INTERSECTIONS)
15D44-02	TRAFFIC CONTROL, SIGNING ON ROADWAYS WITH MILLED SURFACES
15D50-02A	TRAFFIC CONTROL, ADDED LANE CLOSURE WITHOUT LANE SHIFT

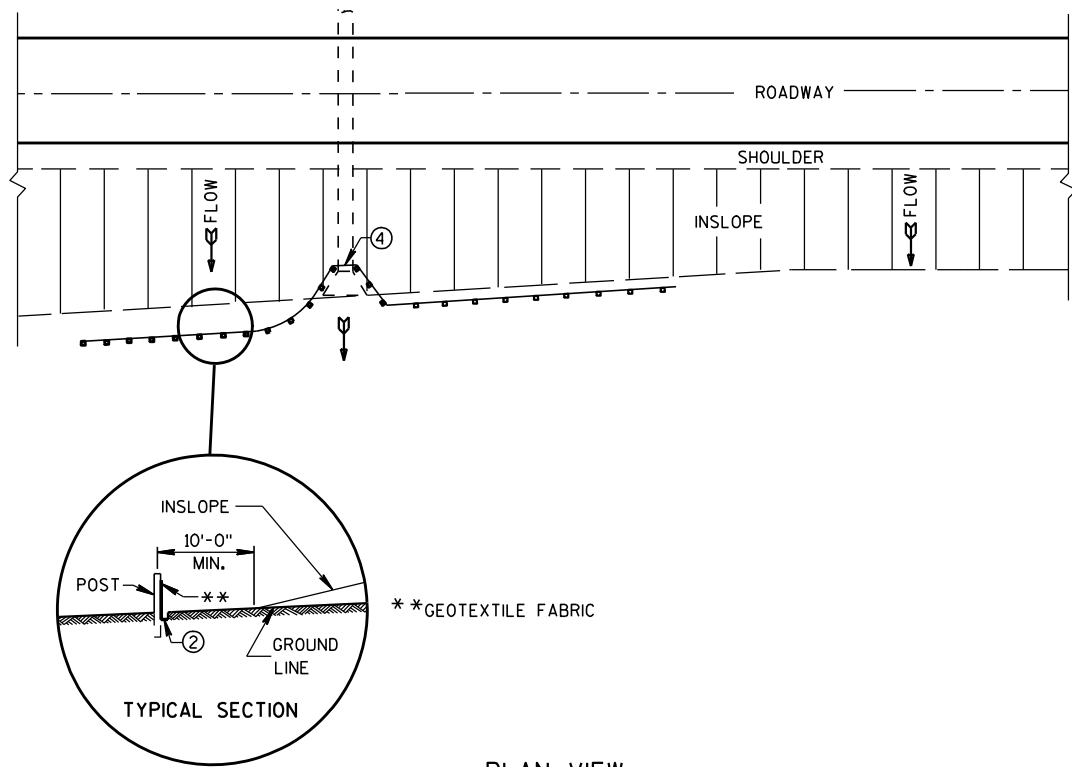

PLAN VIEW
TYPICAL APPLICATION OF SILT FENCE

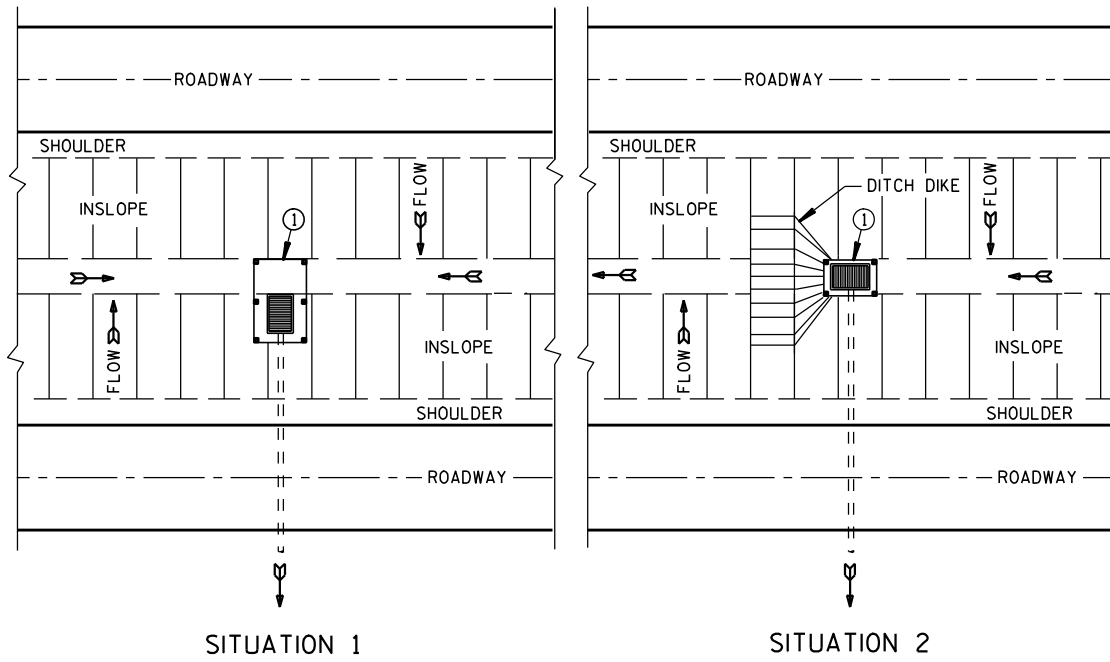

SITUATION 1 SITUATION 2
PLAN VIEW
SILT FENCE AT MEDIAN SURFACE DRAINS

GENERAL NOTES

DETAILS OF CONSTRUCTION NOT SHOWN ON THIS DRAWING SHALL CONFORM TO THE PERTINENT REQUIREMENTS OF THE STANDARD SPECIFICATIONS AND APPLICABLE SPECIAL PROVISIONS.

- ① HORIZONTAL BRACE REQUIRED WITH 2" X 4" WOODEN FRAME OR EQUIVALENT AT TOP OF POSTS.
- ② FOR MANUAL INSTALLATIONS THE TRENCH SHALL BE A MINIMUM OF 4" WIDE & 6" DEEP TO BURY AND ANCHOR THE GEOTEXTILE FABRIC. FOLD MATERIAL TO FIT TRENCH AND BACKFILL & COMPACT TRENCH WITH EXCAVATED SOIL.
- ③ WOOD POSTS SHALL BE A MINIMUM SIZE OF 1 1/8" X 1 1/8" OF OAK OR HICKORY.
- ④ SILT FENCE TO EXTEND ACROSS THE TOP OF THE PIPE.
- ⑤ CONSTRUCT SILT FENCE FROM A CONTINUOUS ROLL IF POSSIBLE BY CUTTING LENGTHS TO AVOID JOINTS. IF A JOINT IS NECESSARY USE ONE OF THE FOLLOWING TWO METHODS; A) OVERLAP THE END POSTS AND TWIST, OR ROTATE, AT LEAST 180 DEGREES, B) HOOK THE END OF EACH SILT FENCE LENGTH.

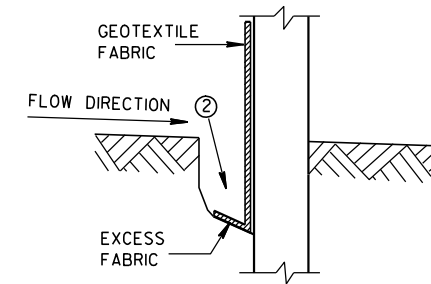

TRENCH DETAIL

NOTE: ADDITIONAL POST DEPTH OR TIE BACKS MAY BE REQUIRED IN UNSTABLE SOILS

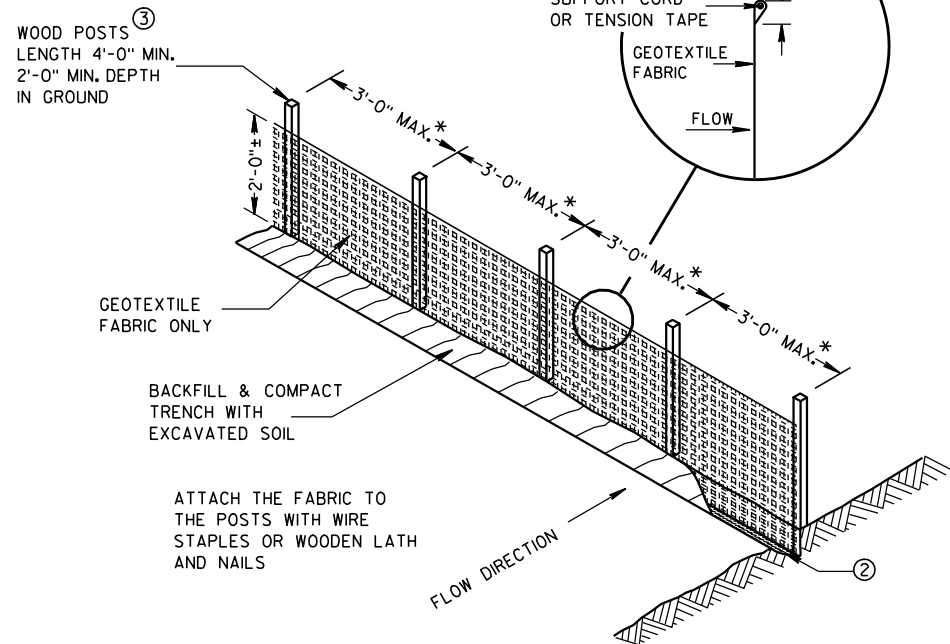

SILT FENCE

* NOTE: 8'-0" POST SPACING ALLOWED IF A WOVEN GEOTEXTILE FABRIC IS USED.

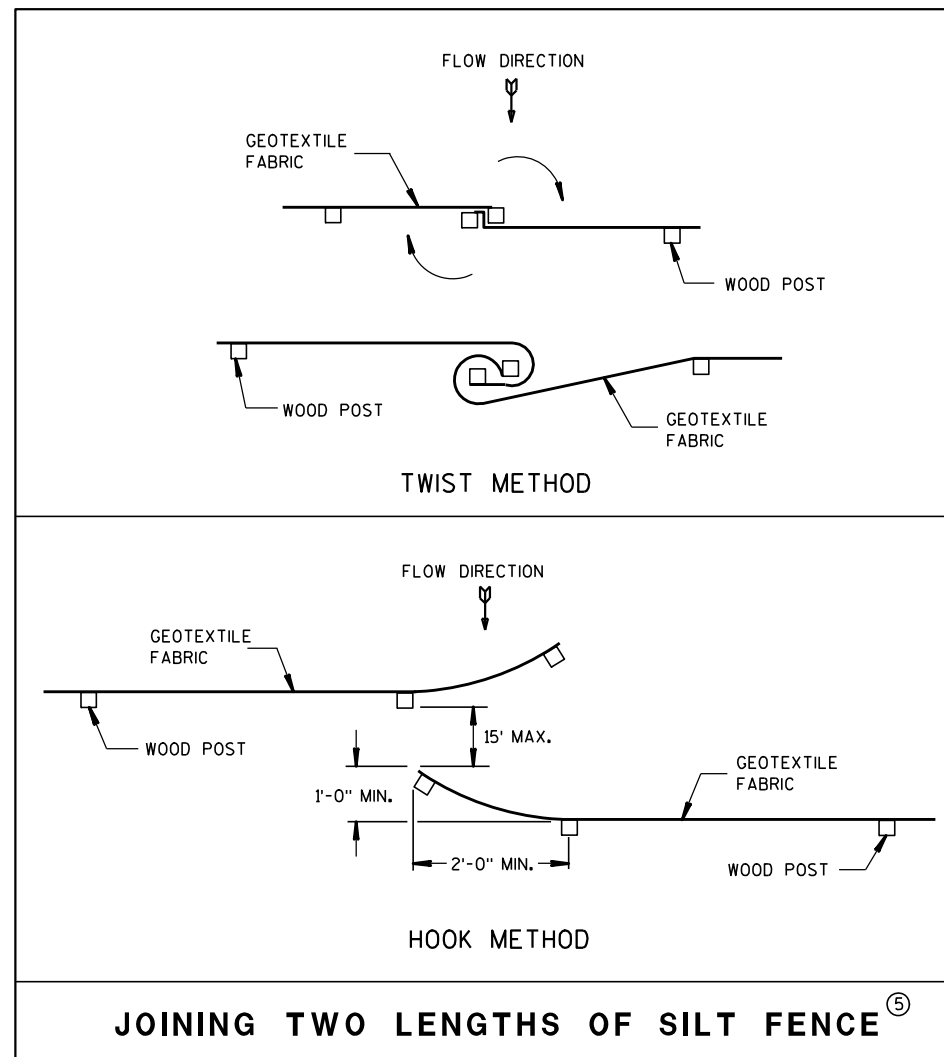

JOINING TWO LENGTHS OF SILT FENCE ⑤

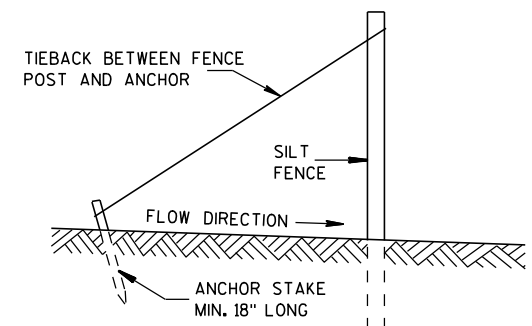

SILT FENCE TIE BACK
(WHEN REQUIRED BY THE ENGINEER)

SILT FENCE

STATE OF WISCONSIN
DEPARTMENT OF TRANSPORTATION

APPROVED
4-29-05 /S/ Beth Canestra
DATE CHIEF ROADWAY DEVELOPMENT ENGINEER
FHWA

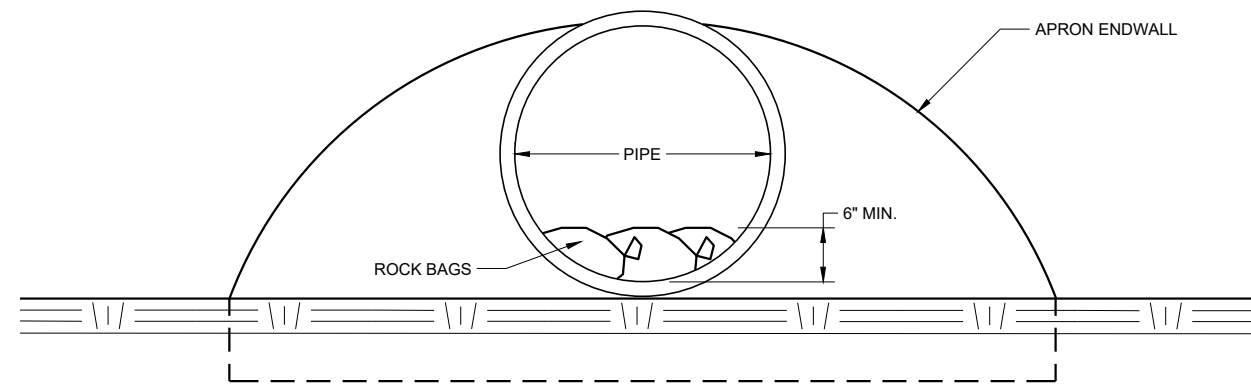

END VIEW

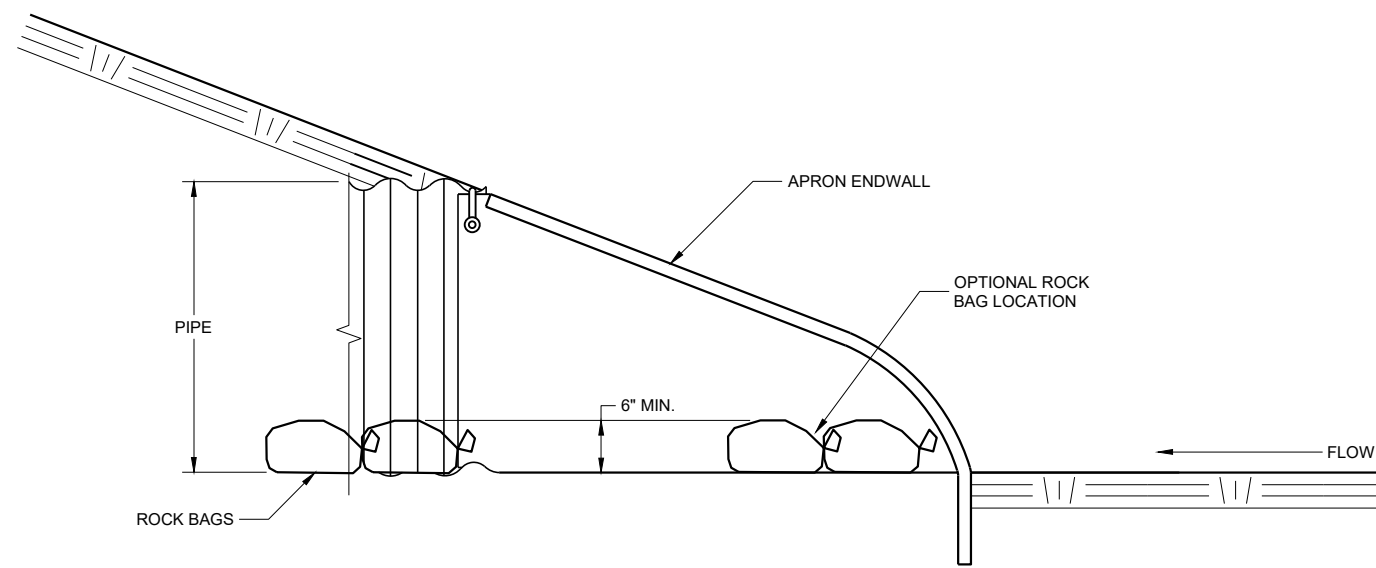

SIDE VIEW

CULVERT PIPE CHECK
(INSTALL ON INLET END ONLY)

CULVERT PIPE CHECK

STATE OF WISCONSIN
DEPARTMENT OF TRANSPORTATION

APPROVED
May 2019 /S/ Daniel Schave
DATE EROSION CONTROL ENGINEER

FHWA

METAL APRON ENDWALLS											
PIPE DIA. (IN.)	MIN. THICK. (Inches)		DIMENSIONS (Inches)							APPROX. SLOPE	BODY
	STEEL	ALUM.	A (±1")	B (MAX.)	H (±1")	L (±1 1/2")	L1	L2	W (±2")		
12	.064	.060	6	6	6	21	12	17 1/2	24	2 1/2 to 1	1 Pc.
15	.064	.060	7	8	6	26	14	21 3/4	30	2 1/2 to 1	1 Pc.
18	.064	.060	8	10	6	31	15	28 1/4	36	2 1/2 to 1	1 Pc.
21	.064	.060	9	12	6	36	18	29 5/8	42	2 1/2 to 1	1 Pc.
24	.064	.075	10	13	6	41	18	37 1/4	48	2 1/2 to 1	1 Pc.
30	.079	.075	12	16	8	51	18	52 1/4	60	2 1/2 to 1	1 Pc.
36	.079	.105	14	19	9	60	24	59 3/4	72	2 1/2 to 1	2 Pc.
42	.109	.105	16	22	11	69	24	75 5/8	84	2 1/2 to 1	2 Pc.
48	.109	.105	18	27	12	78	24	81	90	2 1/4 to 1	3 Pc.
54	.109	.105	18	30	12	84	30	85 1/2	102	2 1/4 to 1	3 Pc.
60	.109x	.105x	18	33	12	87	—	—	114	2 to 1	3 Pc.
66	.109x	.105x	18	36	12	87	—	—	120	2 to 1	3 Pc.
72	.109x	.105x	18	39	12	87	—	—	126	2 to 1	3 Pc.
78	.109x	.105x	18	42	12	87	—	—	132	1 1/2 to 1	3 Pc.
84	.109x	.105x	18	45	12	87	—	—	138	1 1/2 to 1	3 Pc.
90	.109x	.105x	18	37	12	87	—	—	144	1 1/2 to 1	3 Pc.
96	.109x	.105x	18	35	12	87	—	—	150	1 1/2 to 1	3 Pc.

* EXCEPT CENTER PANEL SEE GENERAL NOTES

REINFORCED CONCRETE APRON ENDWALLS									
PIPE DIA. (IN.)	DIMENSIONS (Inches)							APPROX. SLOPE	
	T	A	B	C	D	E	G		
12	2	4	24	48 1/8	72 1/8	24	2	3 to 1	
15	2 1/4	6	27	46	73	30	2 1/4	3 to 1	
18	2 1/2	9	27	46	73	36	2 1/2	3 to 1	
21	2 3/4	9	36	37 1/2	73 1/2	42	2 3/4	3 to 1	
24	3	9 1/2	43 1/2	30	73 1/2	48	3	3 to 1	
27	3 1/4	10 1/2	49 1/2	24	73 1/2	54	3 1/4	3 to 1	
30	3 1/2	12	54	19 3/4	73 1/2	60	3 1/2	3 to 1	
36	4	15	63	34 3/4	97 3/4	72	4	3 to 1	
42	4 1/2	21	63	35	98	78	4 1/2	3 to 1	
48	5	24	72	26	98	84	5	3 to 1	
54	5 1/2	27	65	33 1/4-35	98 1/4-100	90	5 1/2	2 1/2 to 1	
60	6	30-35	60	39	99	96	5	2 to 1	
66	6 1/2	30-35	72-78	21-27	99	102	5 1/2	2 to 1	
72	7	30-35	78	21	99	108	6	2 to 1	
78	7 1/2	30-35	78	21	99	114	6 1/2	2 to 1	
84	8	36	90 1/2	21	111 1/2	120	6 1/2	1 1/2 to 1	
90	8 1/2	41	87 1/2	24	111 1/2	132	6 1/2	1 1/2 to 1	

* MINIMUM
** MAXIMUM

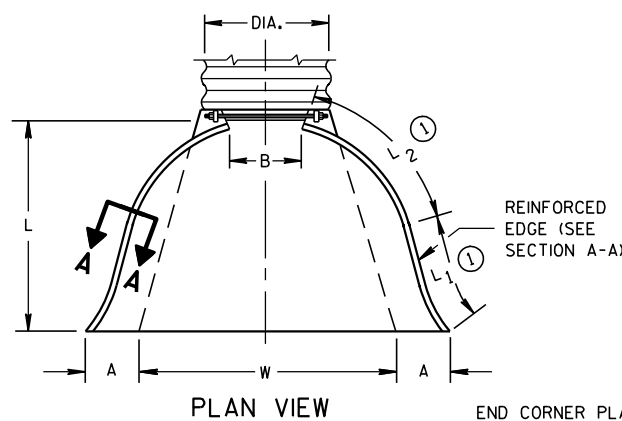

REINFORCED EDGE (SEE SECTION A-A)
END CORNER PLATES MAY BE FASTENED TO APRON PROPER BY BOLTS, RIVETS, OR RESISTANCE SPOT WELDS WHICH WILL HOLD THE SURFACES TIGHTLY TOGETHER

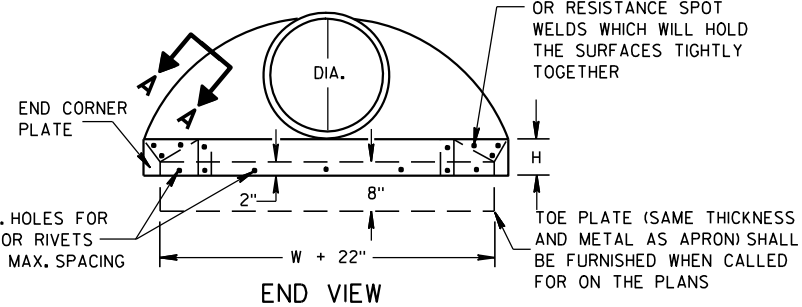

SIDE ELEVATION
METAL ENDWALLS

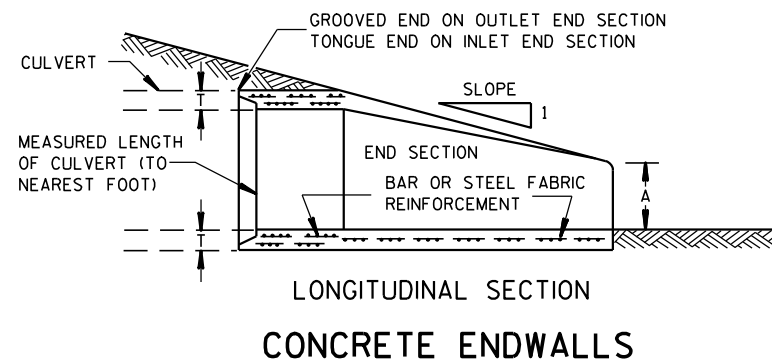
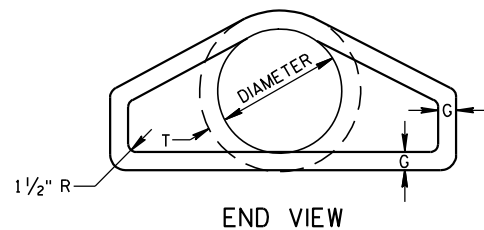
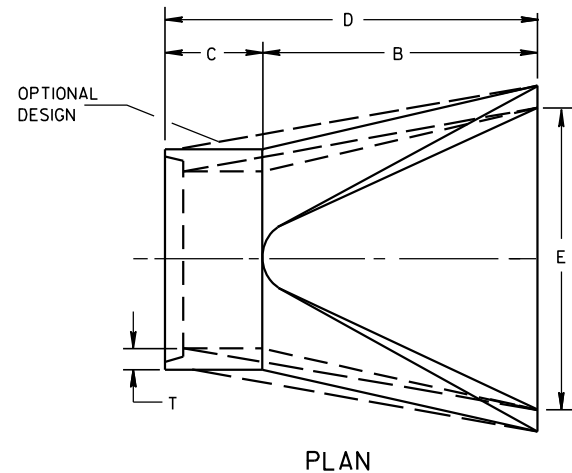

1" WIDE, 12 GA. (0.109" THICK) GALVANIZED STRAP WITH STANDARD 6" X 1/2" BAND BOLT AND NUT

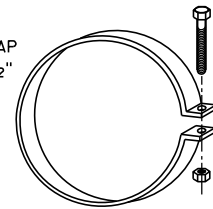

ALTERNATE FOR TYPE 1 CONNECTION
END SECTION CONNECTOR STRAP

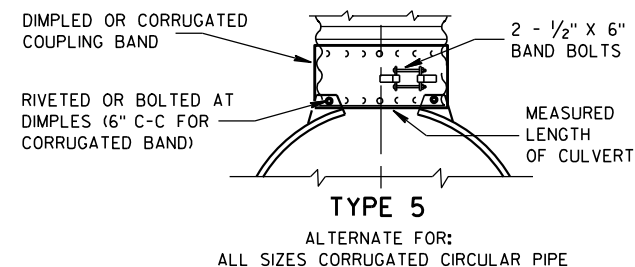
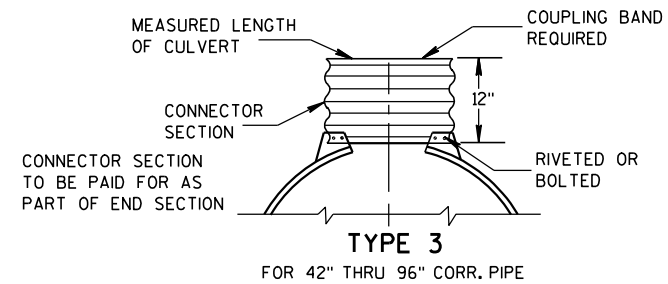
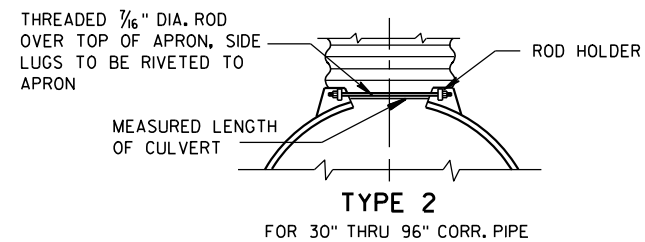
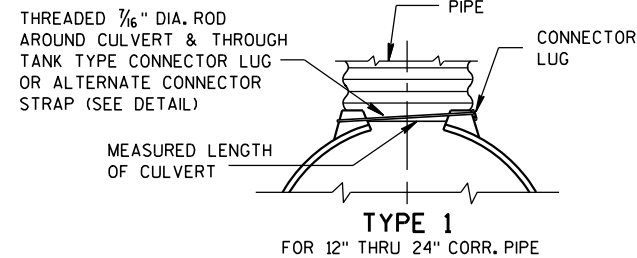

NOTE: DIMPLED BAND FITS OVER OUTSIDE OF ENDWALL, AND CORRUGATED BAND FITS INSIDE ENDWALL. DIMPLED BAND MAY BE USED WITH HELICALLY CORRUGATED PIPE.

FOR CIRCUMFERENTIALLY CORRUGATED PIPE USE ENDWALL CONNECTION DETAILS 1, 2, 3 OR 5 AS APPLICABLE.

FOR HELICALLY CORRUGATED PIPE USE ENDWALL CONNECTION DETAILS 1, 2 OR 5.

FOR HELICALLY CORRUGATED PIPES WITH TWO CIRCUMFERENTIAL CORRUGATIONS AT EACH END USE ENDWALL CONNECTION DETAILS 1, 2 OR 3.

CONNECTION DETAILS

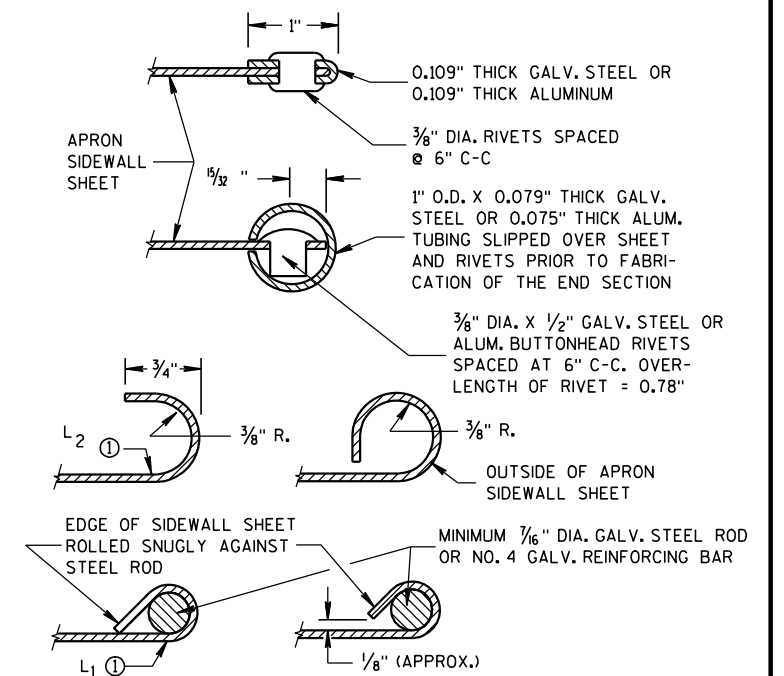

SECTION A-A

GENERAL NOTES

DETAILS OF CONSTRUCTION, MATERIALS AND WORKMANSHIP NOT SHOWN ON THIS DRAWING SHALL CONFORM TO THE PERTINENT REQUIREMENTS OF THE STANDARD SPECIFICATIONS AND THE APPLICABLE SPECIAL PROVISIONS.

CONCRETE CULVERT ENDWALLS MAY NOT BE USED WITH GALVANIZED STEEL OR ALUMINUM CULVERT PIPE OR VICE VERSA. GALVANIZED STEEL OR ALUMINUM ENDWALLS SHALL NORMALLY BE INSTALLED ON CULVERT PIPE OF THE SAME METAL.

ALL THREE PIECE STEEL APRON ENDWALLS FOR 60" DIAMETER PIPE AND LARGER SHALL HAVE 0.109" SIDES AND 0.138" CENTER PANELS. ALL THREE PIECE ALUMINUM APRON ENDWALLS FOR 60" DIAMETER PIPE AND LARGER SHALL HAVE 0.105" SIDES AND 0.134" CENTER PANELS. THE WIDTH OF CENTER PANELS SHALL BE GREATER THAN 20 PERCENT OF THE PIPE PERIMETER.

LAP SEAMS SHALL BE TIGHTLY JOINED BY GALVANIZED RIVETS OR BOLTS FOR STEEL UNITS AND ALUMINUM RIVETS AND BOLTS FOR ALUMINUM UNITS. FOR THE 60" THROUGH 96" DIAMETER APRON ENDWALL SIZES, THE REINFORCED EDGES AND CENTER PANEL SEAMS SHALL BE FURTHER REINFORCED WITH GALVANIZED STEEL OR ALUMINUM STIFFENER ANGLES. THE ANGLES SHALL BE ATTACHED BY GALVANIZED NUTS AND BOLTS FOR STEEL UNITS AND ALUMINUM NUTS AND BOLTS FOR ALUMINUM UNITS.

WHERE TWO OR MORE PIPES WITH APRON ENDWALLS ARE LAID ADJACENT TO EACH OTHER, THEY SHALL BE SEPARATED BY A DISTANCE SUFFICIENT TO PROVIDE A MINIMUM CLEARANCE OF 6 INCHES BETWEEN APRON ENDWALLS.

① FOR PIPE SIZES UP TO 60" DIAMETER, A 180° ROLLED EDGE MAY BE USED INSTEAD OF STEEL ROD REINFORCEMENT. SEE SECTION A-A.

APRON ENDWALLS FOR
CULVERT PIPE

STATE OF WISCONSIN
DEPARTMENT OF TRANSPORTATION

APPROVED
11/30/94 DATE /S/ Rory L. Rhinesmith
CHIEF ROADWAY DEVELOPMENT ENGINEER
FHWA

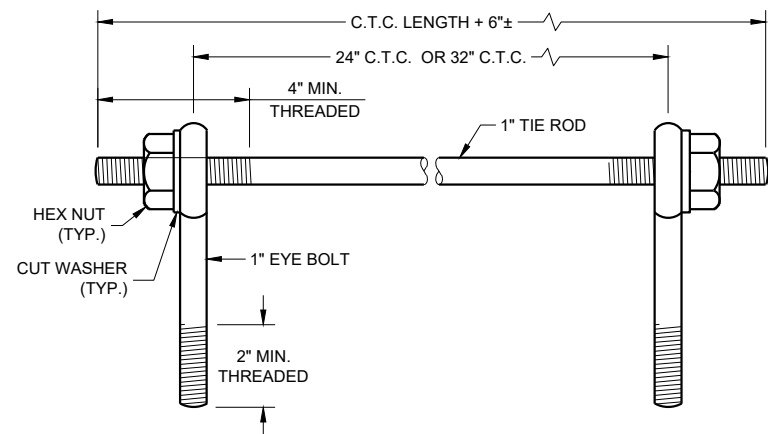

EYE BOLTS AND TIE ROD

EYE BOLT AND TIE ROD ASSEMBLY (ALTERNATE NO. 1)

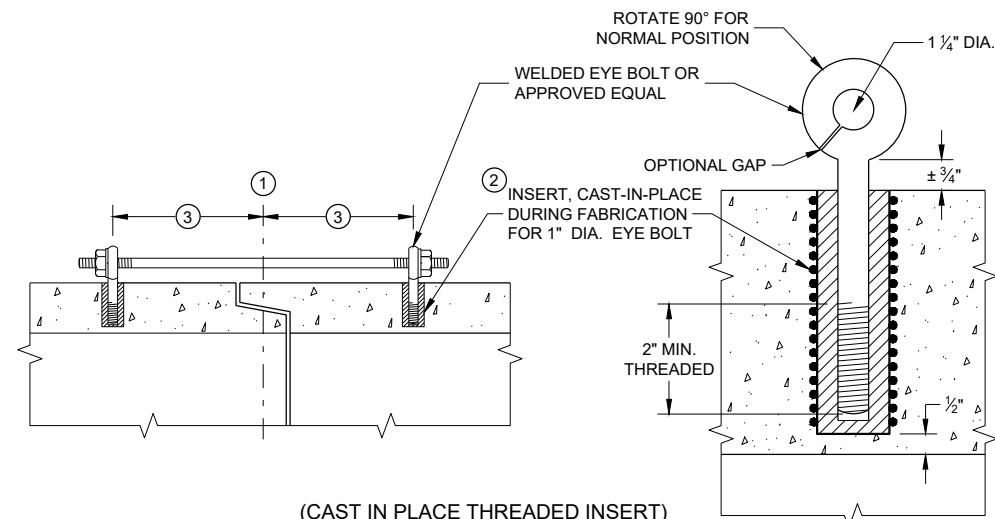

(CAST IN PLACE THREADED INSERT)
LONGITUDINAL SECTIONS

GENERAL NOTES

DETAILS OF CONSTRUCTION, MATERIALS, AND WORKMANSHIP NOT SHOWN ON THIS DRAWING SHALL CONFORM TO THE PERTINENT REQUIREMENTS OF THE STANDARD SPECIFICATIONS AND APPLICABLE SPECIAL PROVISIONS.

CONCRETE CULVERT AND STORM SEWER PIPE SHALL BE TIED TOGETHER IN THE MANNER ILLUSTRATED BY THIS DETAIL AT LOCATIONS DESIGNATED IN THE STANDARD SPECIFICATIONS AND THE PLAN. THE CONTRACTOR MAY USE EITHER ALTERNATE 1, 2 OR 3 FOR DRAINAGE STRUCTURES. ONLY ALTERNATE 1 AND 3 MAY BE USED FOR CATTLE PASSES, UNLESS OTHERWISE STATED IN THE CONTRACT. THE MATERIALS, FABRICATION AND WORK NECESSARY TO TIE THE PIPE BY THIS DETAIL WILL BE CONSIDERED INCIDENTAL TO THE PIPE AND APRON ENDWALLS IF REQUIRED.

DETAILED DRAWINGS FOR PROPOSED ALTERNATE DESIGNS FOR JOINT TIES SHALL BE SUBMITTED TO THE ENGINEER FOR APPROVAL.

JOINT TIES TO BE HOT-DIP GALVANIZED PER ASTM A 153.

- ① CENTER LINE OF TONGUE AND GROOVE OR BELL AND SPIGOT JOINTS.
- ② THE INSIDE OF THE THREADED INSERTS SHALL BE CLEAN TO ALLOW THE INSERTION OF THREADED EYE BOLTS.
- ③ HOLES SHALL BE CAST-IN-PLACE OR DRILLED PER THE APPLICABLE DETAIL, AND EQUAL DISTANCE FROM THE CENTERLINE OF THE JOINT.
- ④ BOLT PROJECTION INSIDE OF PIPE SHALL NOT EXCEED 2 INCHES.
- ⑤ OPENING TO BE ROD DIAMETER PLUS 1 INCH.
- ⑥ LENGTH ADEQUATE TO EXTEND TO WITHIN 1/2 INCH OF THE INNER SURFACE OF THE PIPE.
- ⑦ EYE BOLT LENGTH DETERMINED BY WALL THICKNESS, BELL THICKNESS AND BOLT PROJECTION INSIDE PIPE.

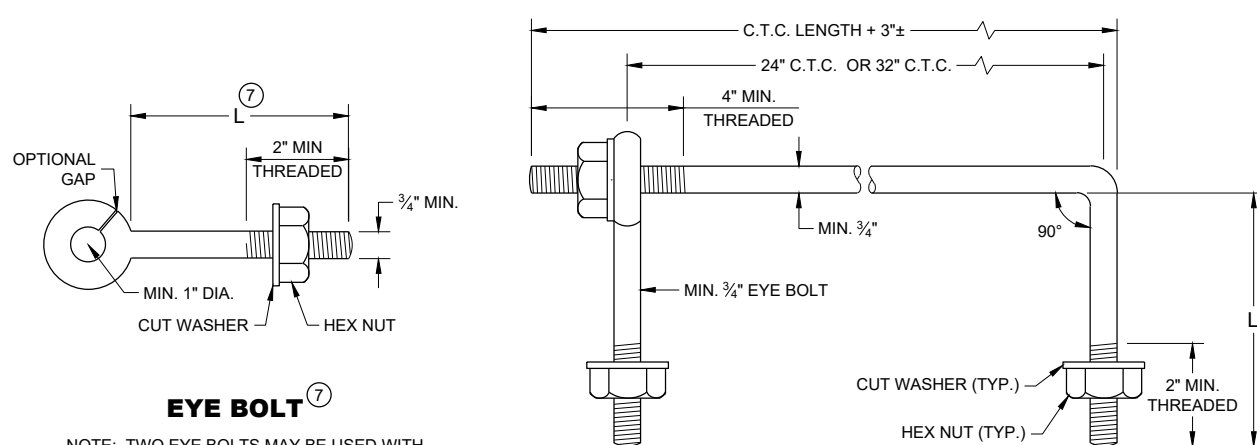

EYE BOLT ⑦

NOTE: TWO EYE BOLTS MAY BE USED WITH A 30" OR 38" LONG THREADED ROD IN LIEU OF THE 90° BENT TIE ROD.

EYE BOLT AND TIE ROD

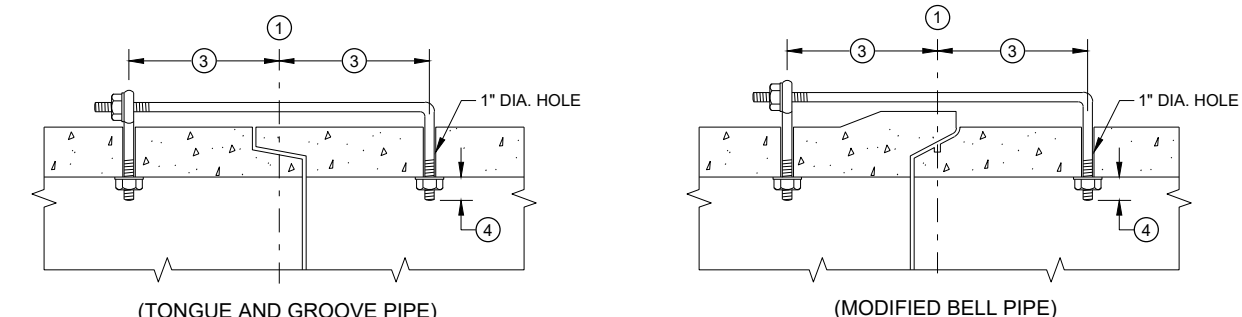

LONGITUDINAL SECTION

(JOINT TIES FOR 18" TO 66" DIA. CONCRETE PIPE)

EYE BOLT AND TIE ROD ASSEMBLY (ALTERNATE NO. 2)

ADJUSTABLE TIE ROD TABLE

PIPE DIAMETER	TIE ROD DIAMETER	D	L ₁	N
12 - 60	5/8	5/8	5	1/2
66 - 84	3/4	3/4	5	1/2
90 - 144	1	1	7	1 1/16

DIMENSIONS SHOWN ARE IN INCHES

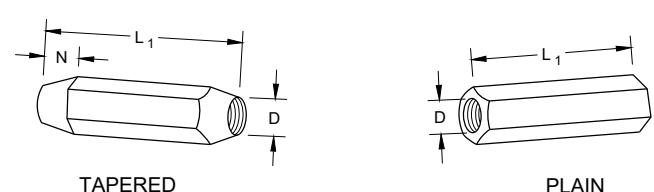

RIGHT AND LEFT THREADS SLEEVE NUTS

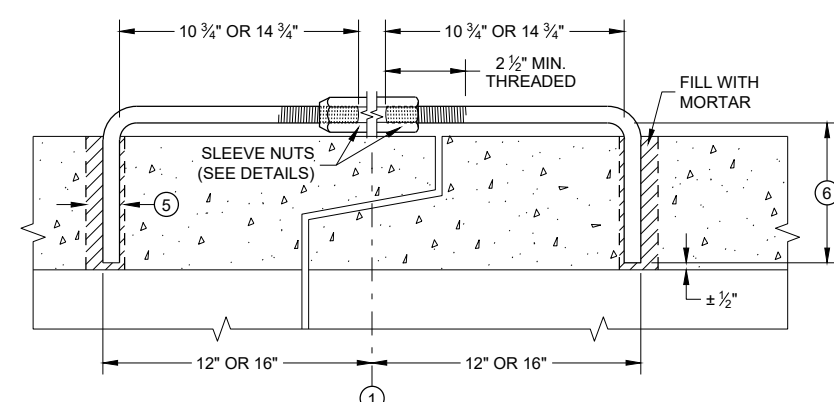

LONGITUDINAL SECTION

ADJUSTABLE TIE ROD (ALTERNATE NO. 3)

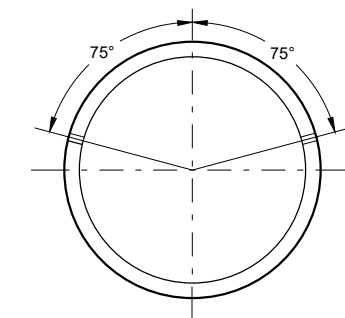

PLACEMENT OF (2) CAST-IN-PLACE INSERTS OR HOLES DURING FABRICATION FOR PIPE SECTIONS REQUIRING TIE RODS

TRANSVERSE SECTION

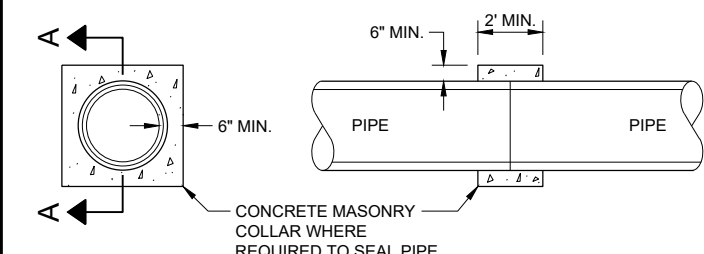

SECTION A - A

CONCRETE COLLAR DETAIL

JOINT TIES FOR CONCRETE PIPE AND CONCRETE COLLAR DETAIL

STATE OF WISCONSIN
DEPARTMENT OF TRANSPORTATION

APPROVED
November 2021 /S/ Rodney Taylor
DATE ROADWAY STANDARDS DEVELOPMENT
ENGINEER
FHWA

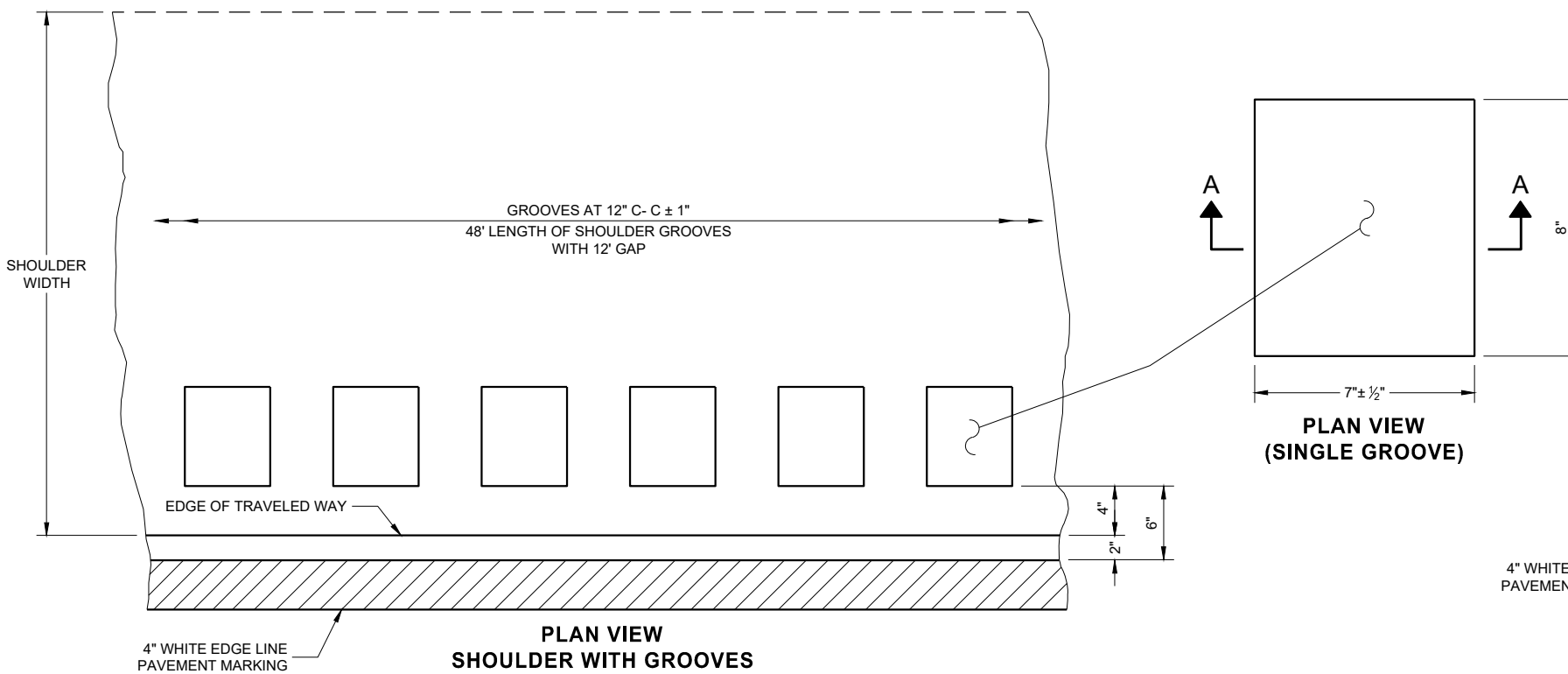

PLAN VIEW SHOULDER WITH GROOVES
PLACEMENT DETAIL FOR TYPE 1 MILLED RUMBLE STRIP

GENERAL NOTES

DETAILS OF CONSTRUCTION NOT SHOWN ON THIS DRAWING SHALL CONFORM TO THE PERTINENT REQUIREMENTS OF THE STANDARD SPECIFICATIONS AND APPLICABLE SPECIAL PROVISIONS.

DO NOT MILL SHOULDER GROOVES THROUGH ANY INTERSECTION, MARKED CROSSWALK, NON-MOTORIZED PATH CROSSING, OR SNOWMOBILE CROSSING.

- ① SHOULDER GROOVES MAY BE OMITTED IN AREAS WITH HIGH CONCENTRATIONS OF DRIVEWAYS. WHEN DIRECTED BY THE ENGINEER.

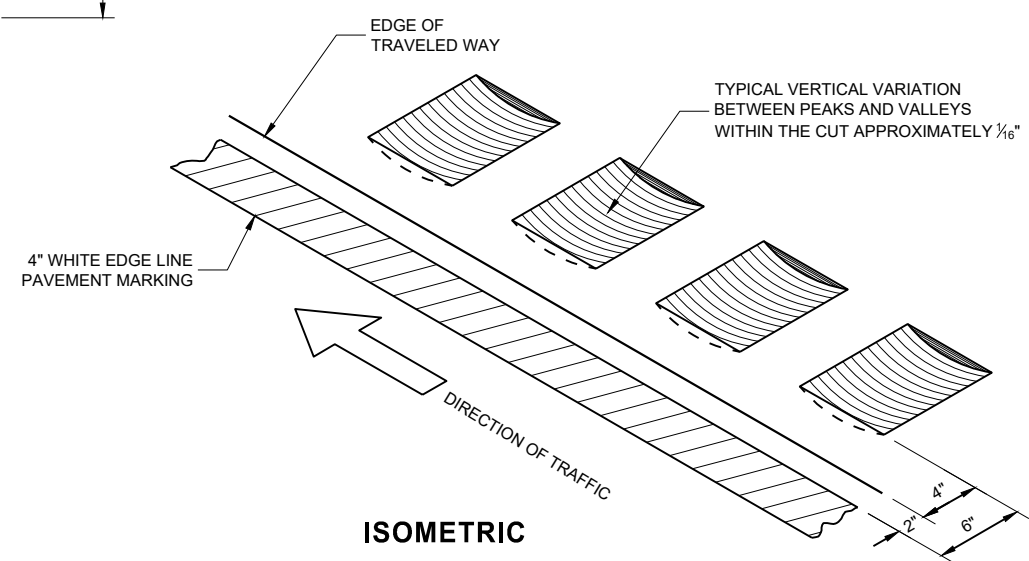

ISOMETRIC

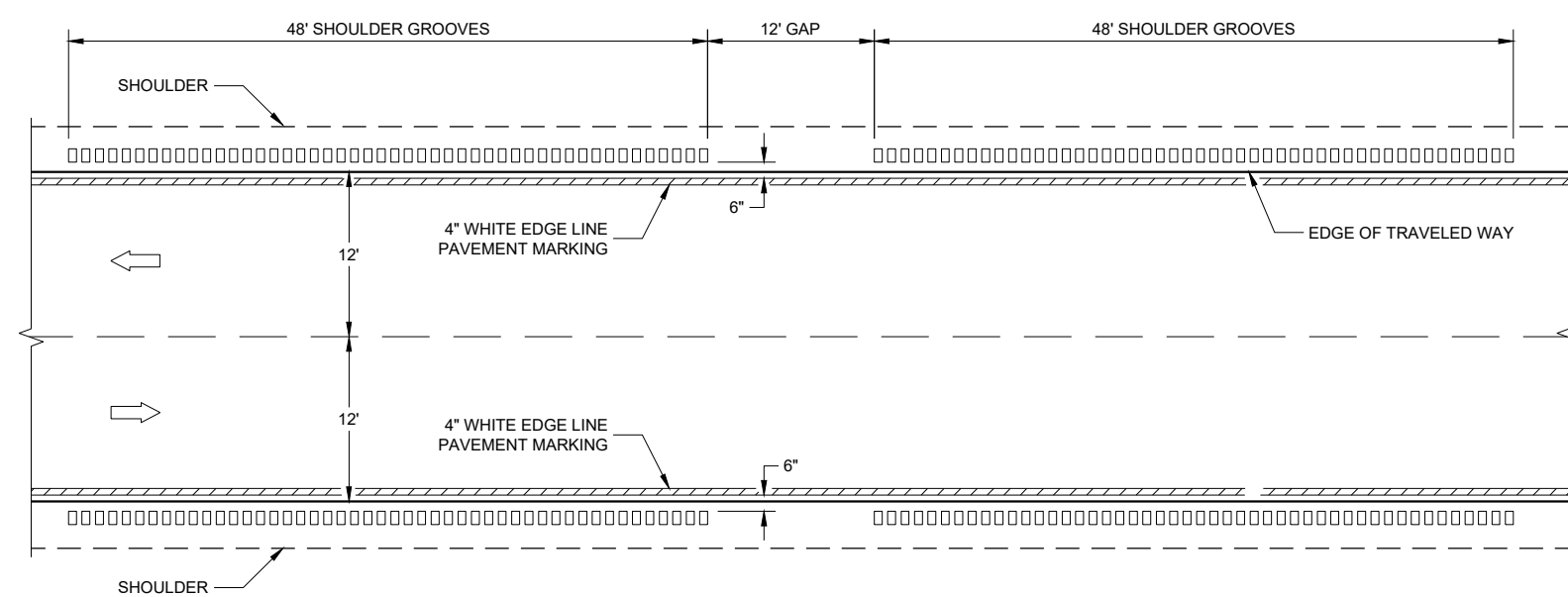

TYPE 1
2 - LANE SHOULDER RUMBLE STRIP

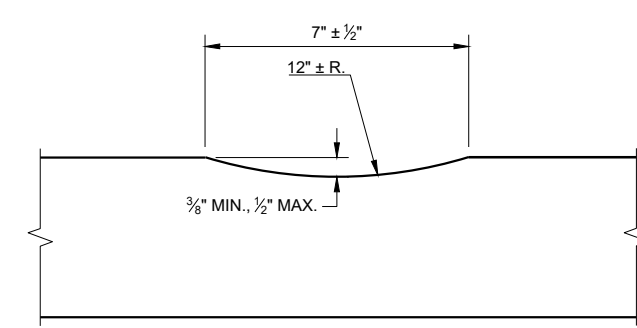

SECTION A - A

2-LANE RURAL SHOULDER RUMBLE STRIP, MILLING

STATE OF WISCONSIN
DEPARTMENT OF TRANSPORTATION

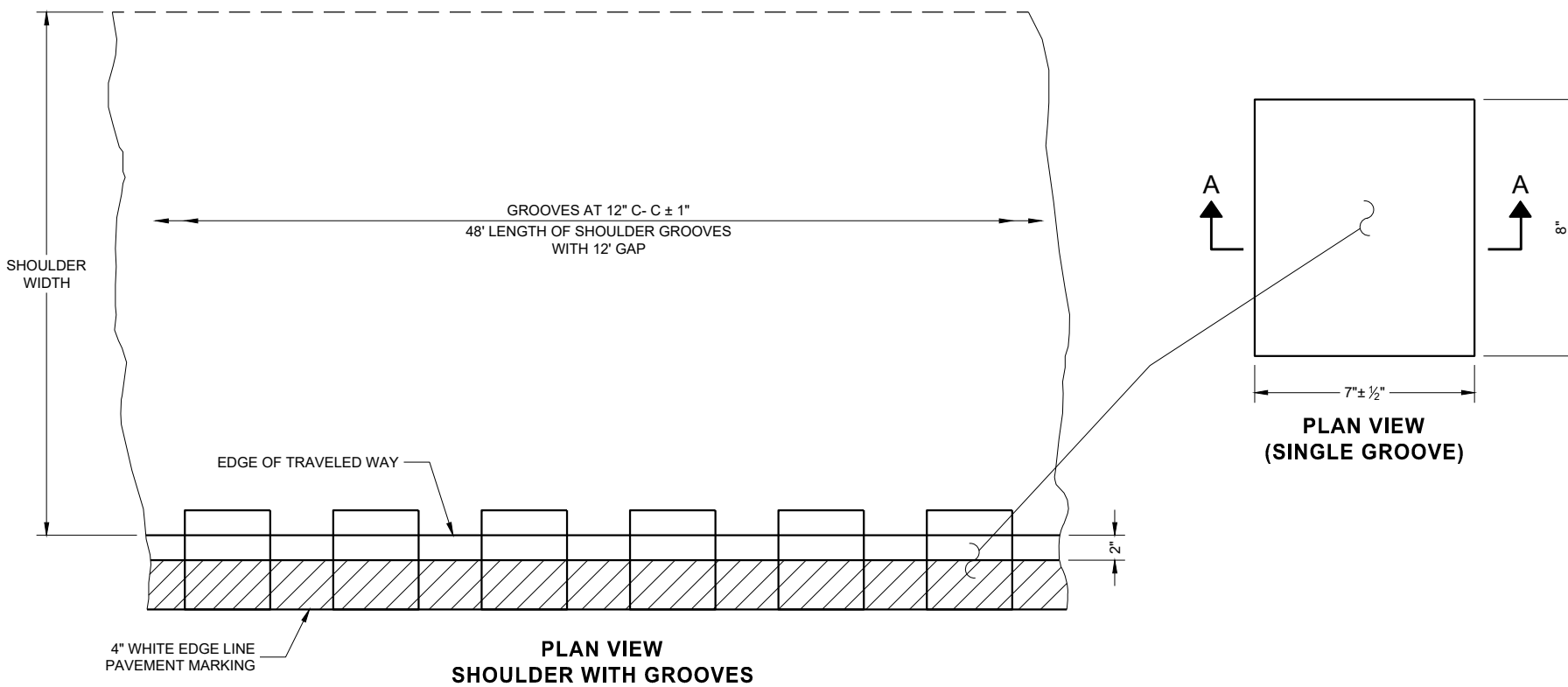

PLACEMENT DETAIL FOR TYPE 2 MILLED RUMBLE STRIP

GENERAL NOTES

DETAILS OF CONSTRUCTION NOT SHOWN ON THIS DRAWING SHALL CONFORM TO THE PERTINENT REQUIREMENTS OF THE STANDARD SPECIFICATIONS AND APPLICABLE SPECIAL PROVISIONS.

DO NOT MILL SHOULDER GROOVES THROUGH ANY INTERSECTION, MARKED CROSSWALK, NON-MOTORIZED PATH CROSSING, OR SNOWMOBILE CROSSING.

- ① SHOULDER GROOVES MAY BE OMITTED IN AREAS WITH HIGH CONCENTRATIONS OF DRIVEWAYS. WHEN DIRECTED BY THE ENGINEER.

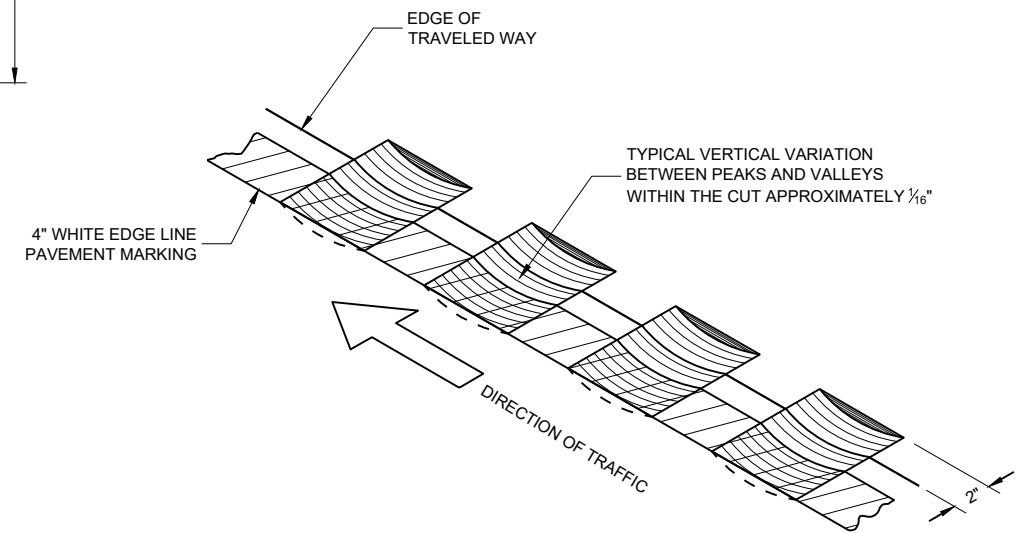

ISOMETRIC

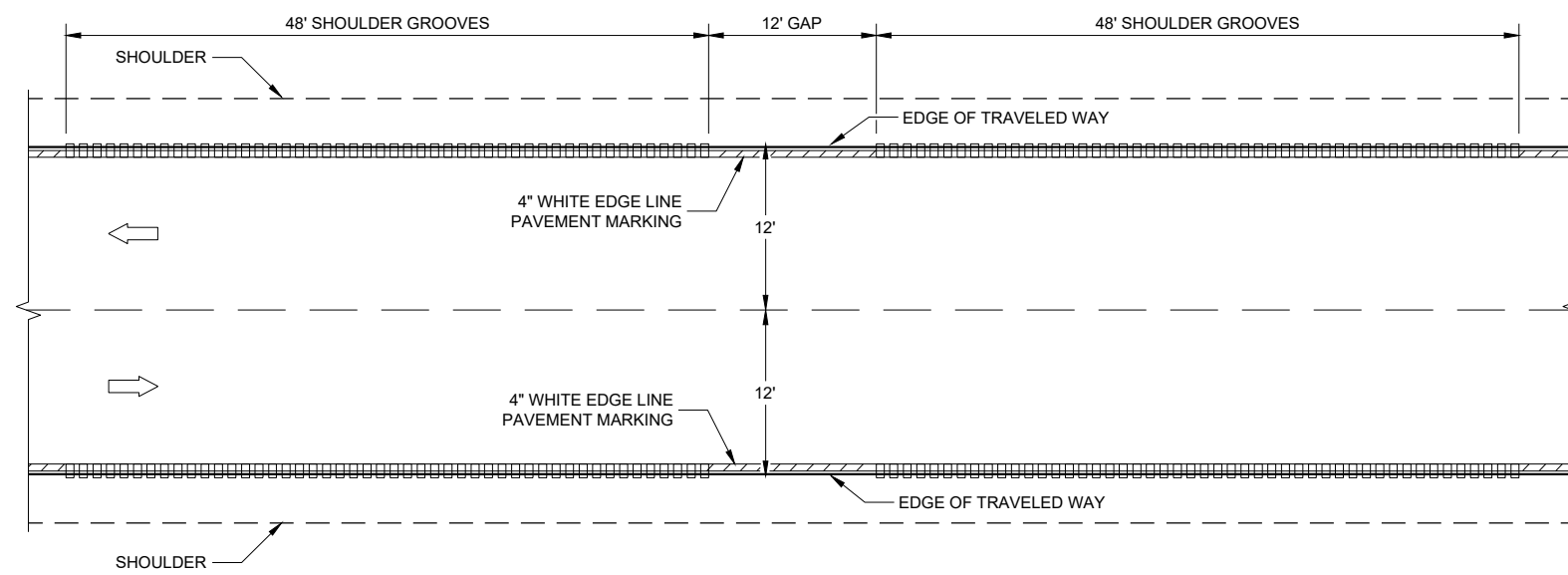

TYPE 2
2 - LANE SHOULDER RUMBLE STRIP

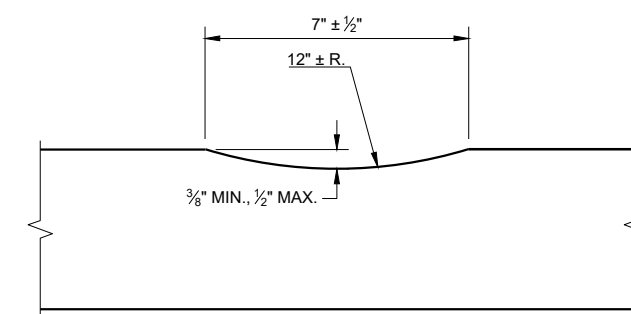

SECTION A - A

**2-LANE RURAL SHOULDER
RUMBLE STRIP, MILLING**

STATE OF WISCONSIN
DEPARTMENT OF TRANSPORTATION

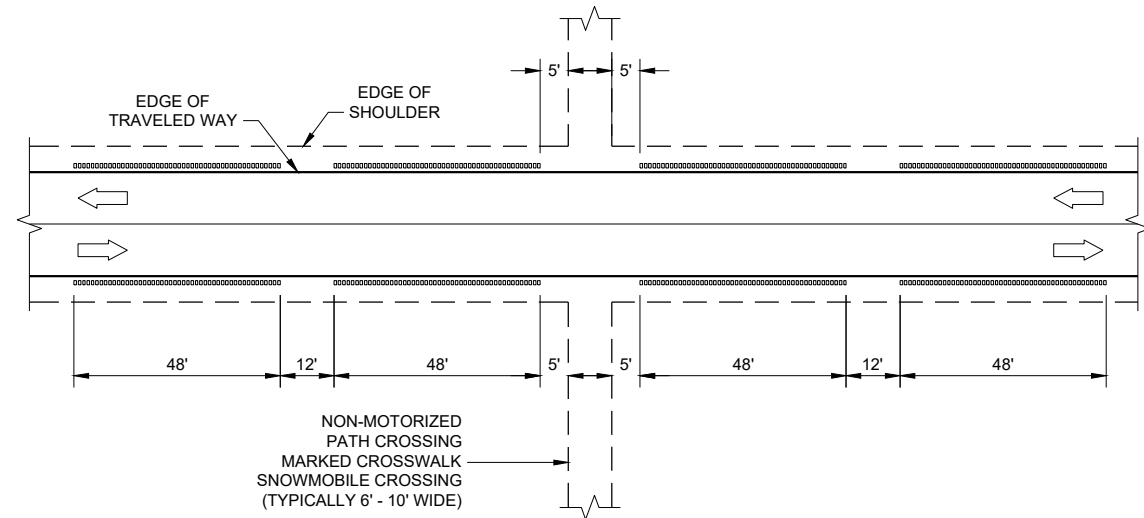

SHOULDER GROOVES AT MISCELLANEOUS CROSSINGS

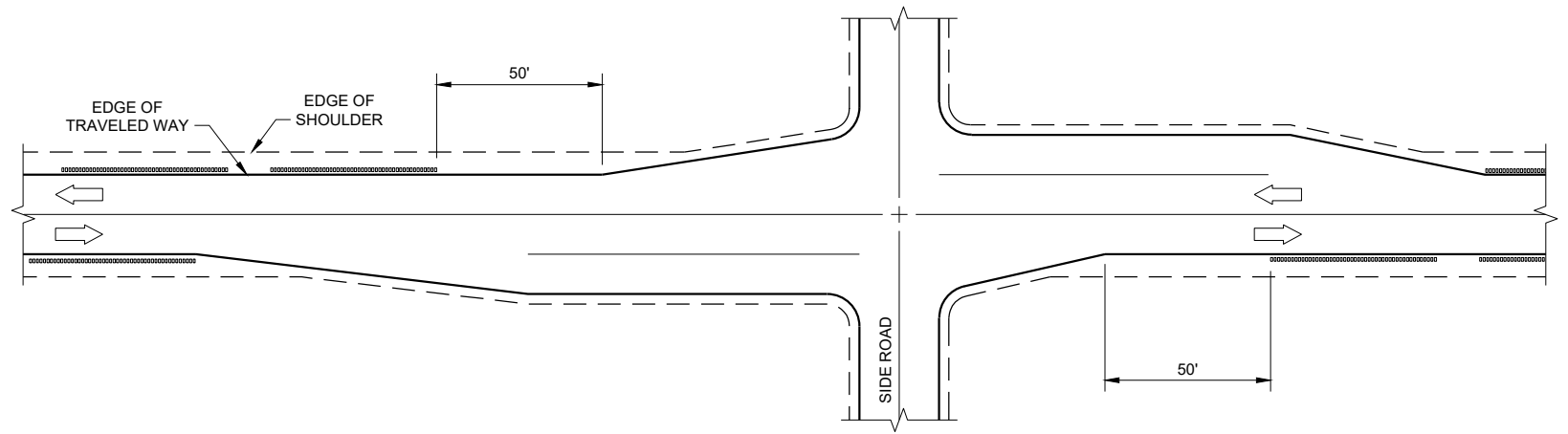

SHOULDER GROOVES AT RIGHT TURN LANE

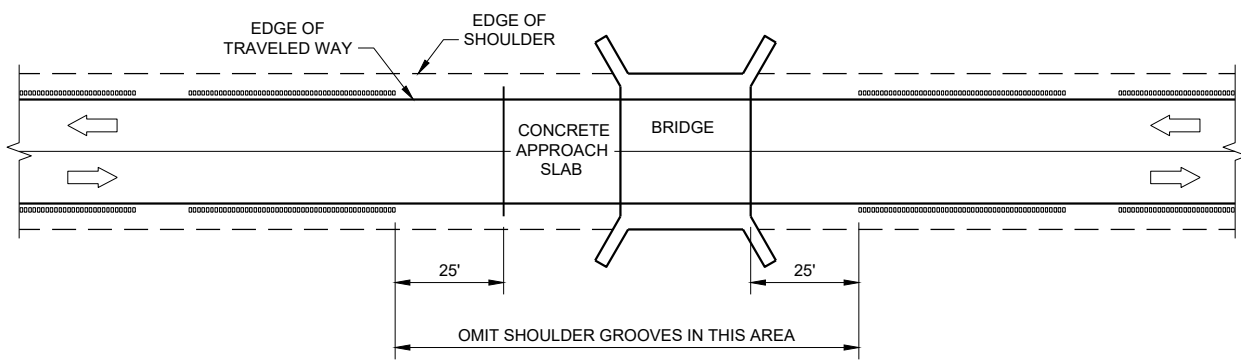

SHOULDER GROOVES AT BRIDGES

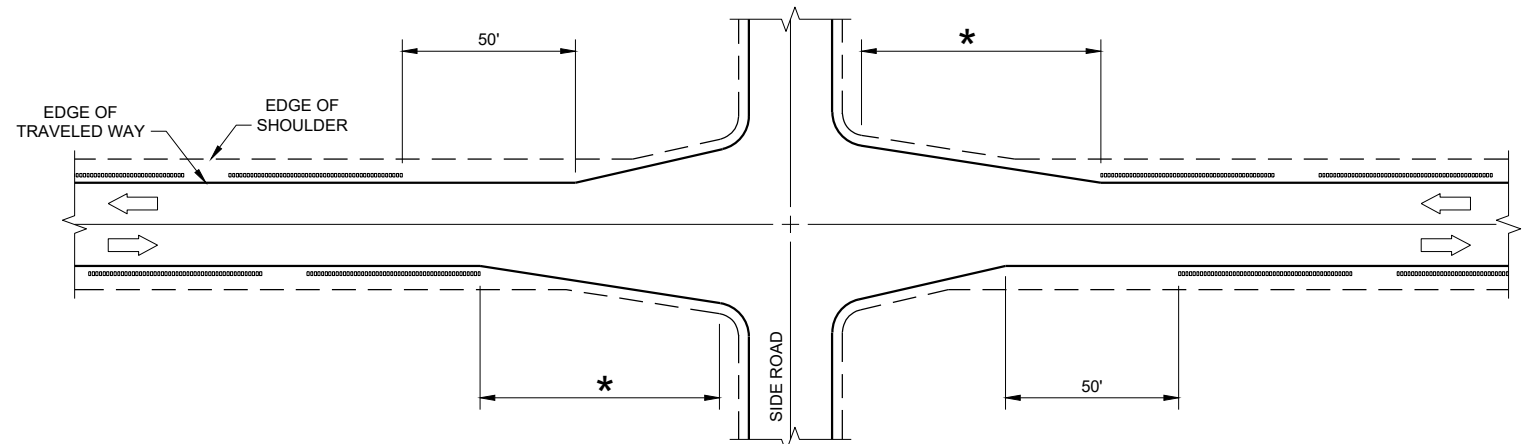

SHOULDER GROOVES AT INTERSECTIONS WITH APPROACH TAPER

* GREATER OF 100' OR APPROACH TAPER LENGTH

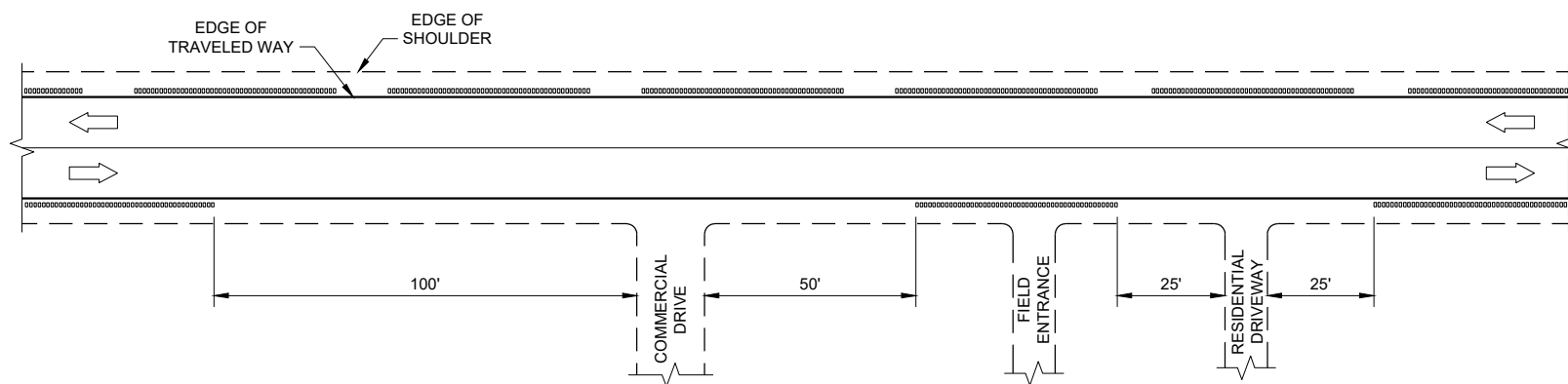

SHOULDER GROOVES AT DRIVEWAYS^①

GENERAL NOTES

- ① SHOULDER GROOVES MAY BE OMITTED IN AREAS WITH HIGH CONCENTRATIONS OF DRIVEWAYS. WHEN DIRECTED BY THE ENGINEER.

**2-LANE RURAL SHOULDER
RUMBLE STRIP, MILLING**

STATE OF WISCONSIN
DEPARTMENT OF TRANSPORTATION

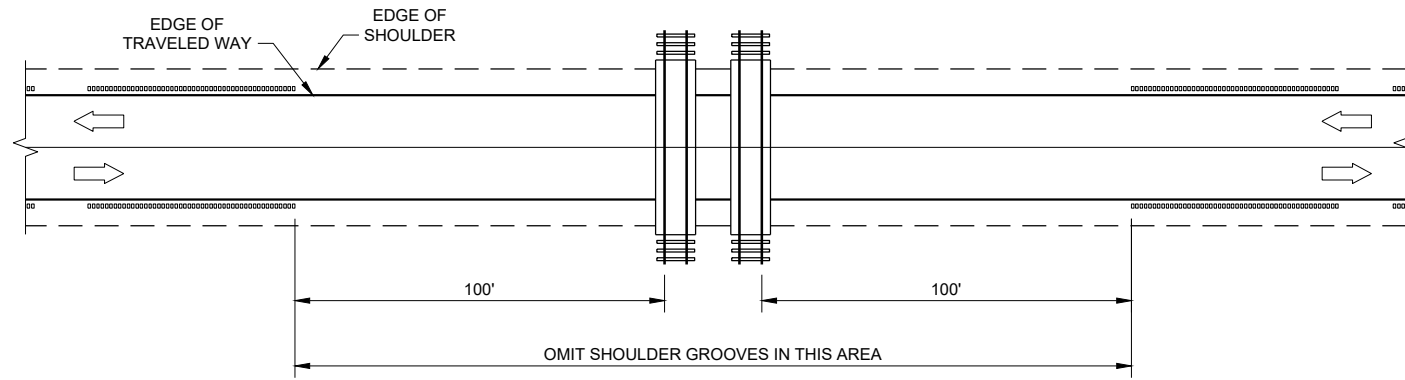

SHOULDER GROOVES AT RAILROADS

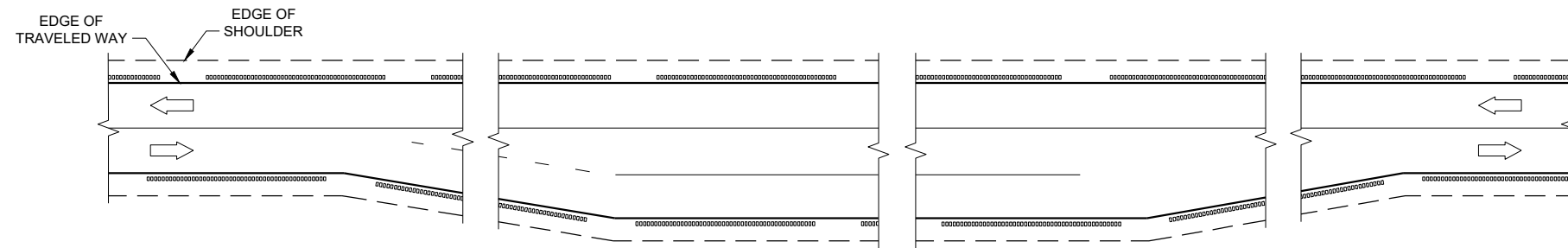

SHOULDER GROOVES AT PASSING AND CLIMBING LANES

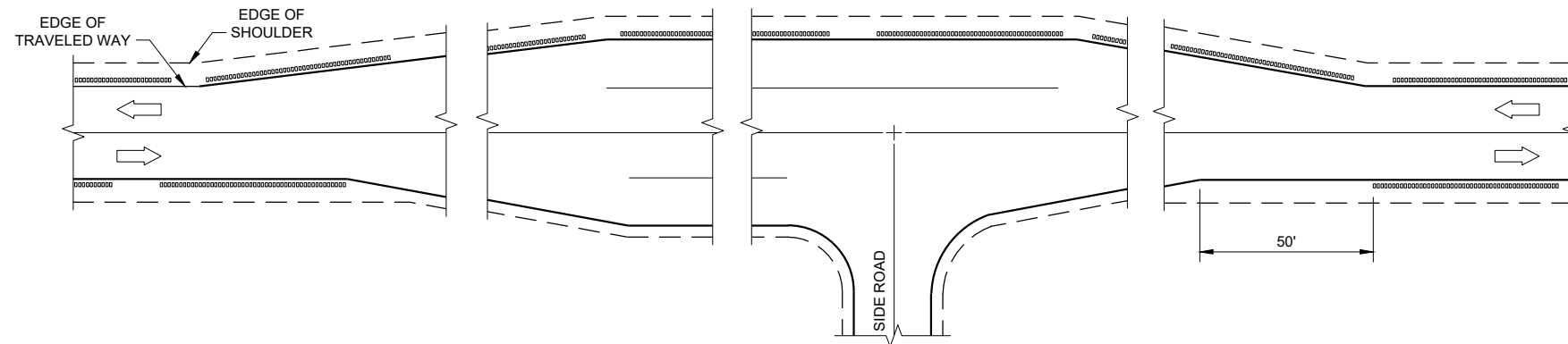

SHOULDER GROOVES AT BYPASS LANES

**2-LANE RURAL SHOULDER
RUMBLE STRIP, MILLING**

STATE OF WISCONSIN
DEPARTMENT OF TRANSPORTATION

APPROVED
7/2018 DATE /S/ Rodney Taylor
ROADWAY STANDARDS DEVELOPMENT
ENGINEER

GENERAL NOTES

DETAILS OF CONSTRUCTION NOT SHOWN ON THIS DRAWING SHALL CONFORM TO THE PERTINENT REQUIREMENTS OF THE STANDARD SPECIFICATIONS AND APPLICABLE SPECIAL PROVISIONS.

DO NOT MILL CENTERLINE GROOVES THROUGH ANY INTERSECTION, MARKED CROSSWALK, NON-MOTORIZED PATH CROSSING, OR SNOWMOBILE CROSSING.

INSTALL PAVEMENT MARKING AFTER THE GROOVES ARE INSTALLED.

SEE SIGNING PLAN FOR SIGN REQUIREMENTS THAT MAY BE NEEDED.

- ① CENTERLINE GROOVES MAY BE OMITTED IN AREAS WITH HIGH CONCENTRATIONS OF DRIVEWAYS. WHEN DIRECTED BY THE ENGINEER.

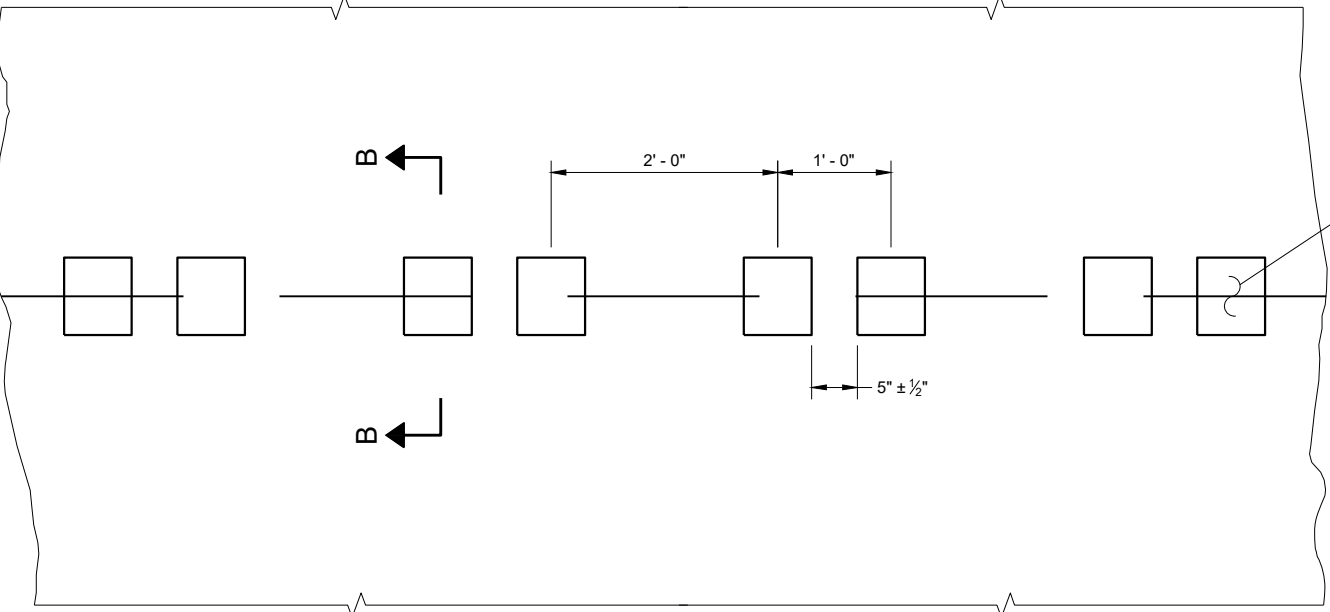

**PLAN VIEW
SHOULDER WITH GROOVES**

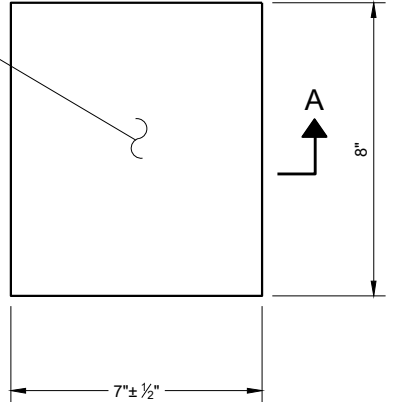

**PLAN VIEW
(SINGLE GROOVE)**

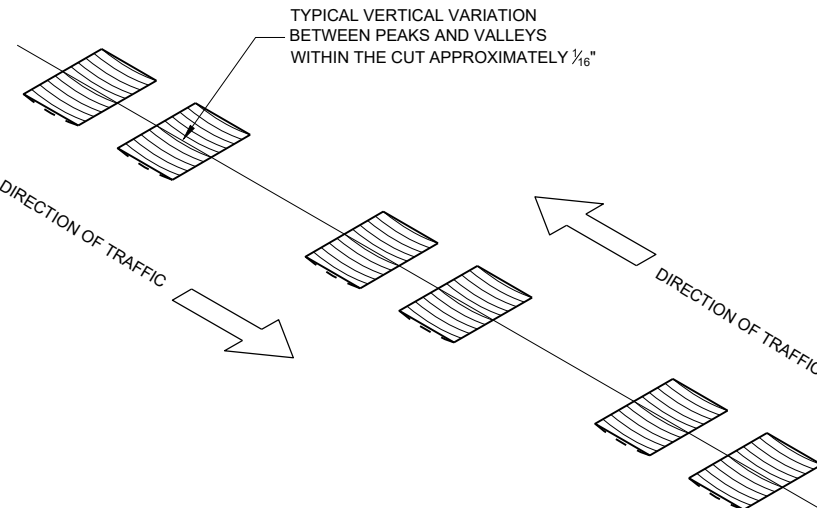

ISOMETRIC

PLACEMENT DETAIL FOR TYPE 1 MILLED RUMBLE STRIP

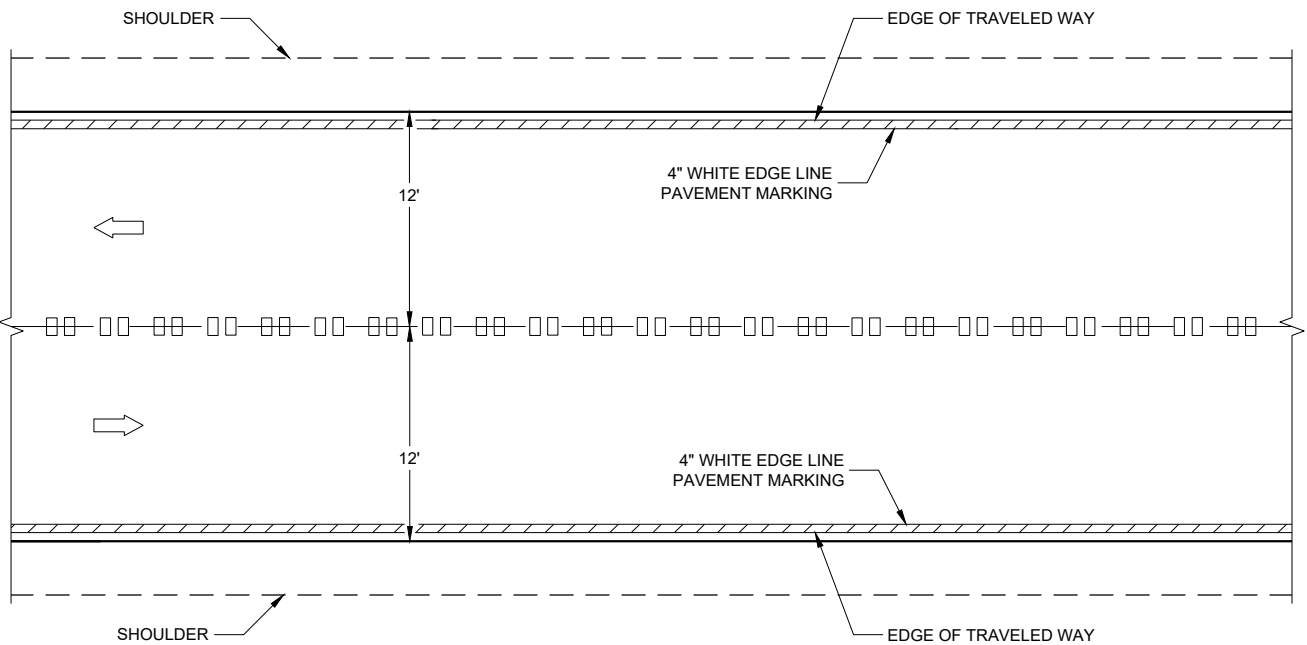

CENTERLINE GROOVES ON TWO-WAY ROADWAYS

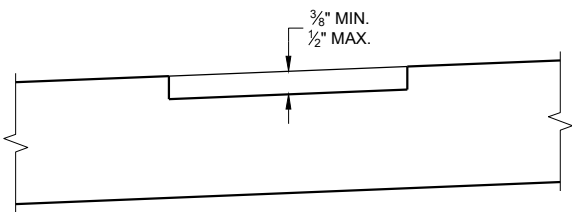

**SECTION B - B
SUPERELEVATED ROADWAY**

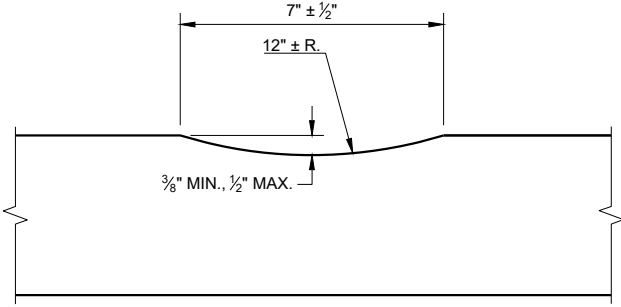

SECTION A - A

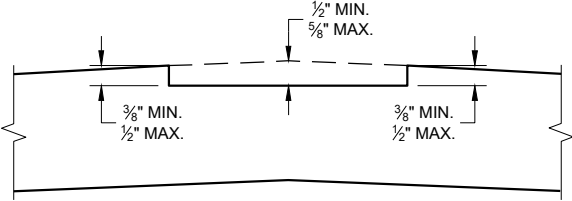

**SECTION B - B
CROWNED ROADWAY**

**2-LANE RURAL
CENTER LINE RUMBLE STRIP,
MILLING**

STATE OF WISCONSIN
DEPARTMENT OF TRANSPORTATION

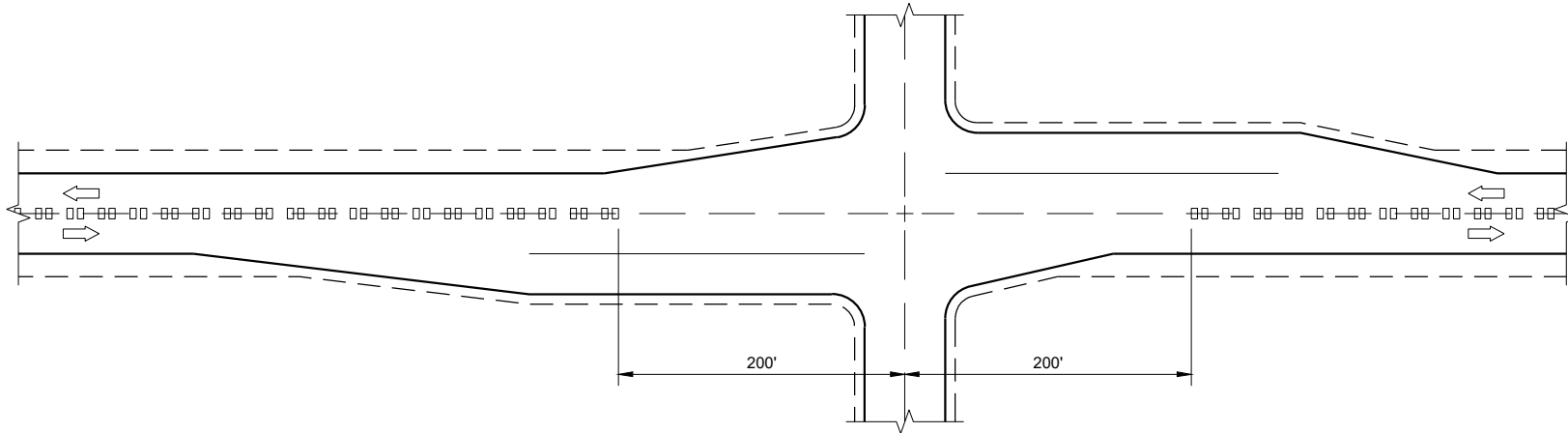

CENTERLINE GROOVES AT INTERSECTIONS

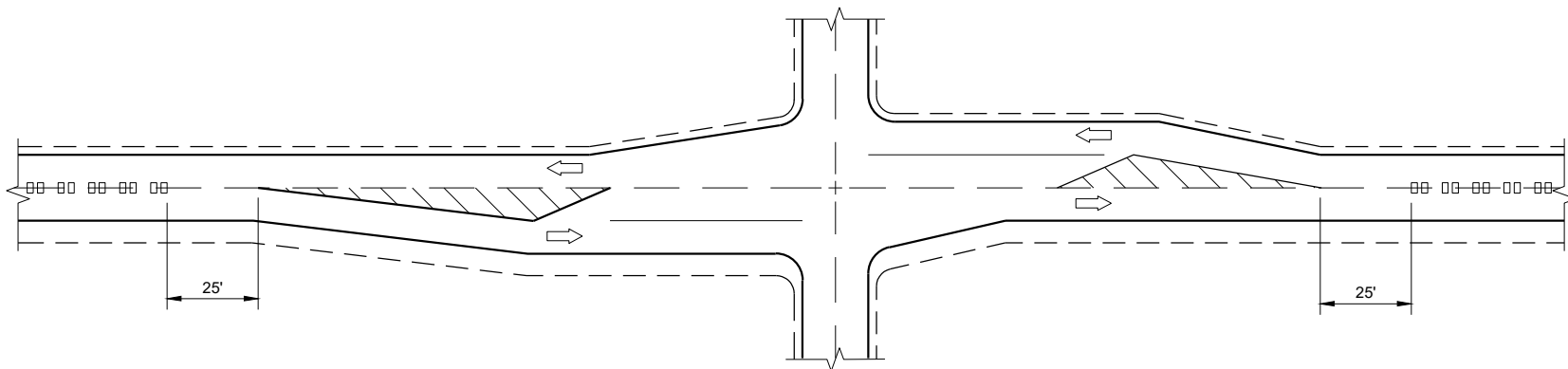

**CENTERLINE GROOVES AT INTERSECTIONS
(WITH LEFT TURN LANES)**

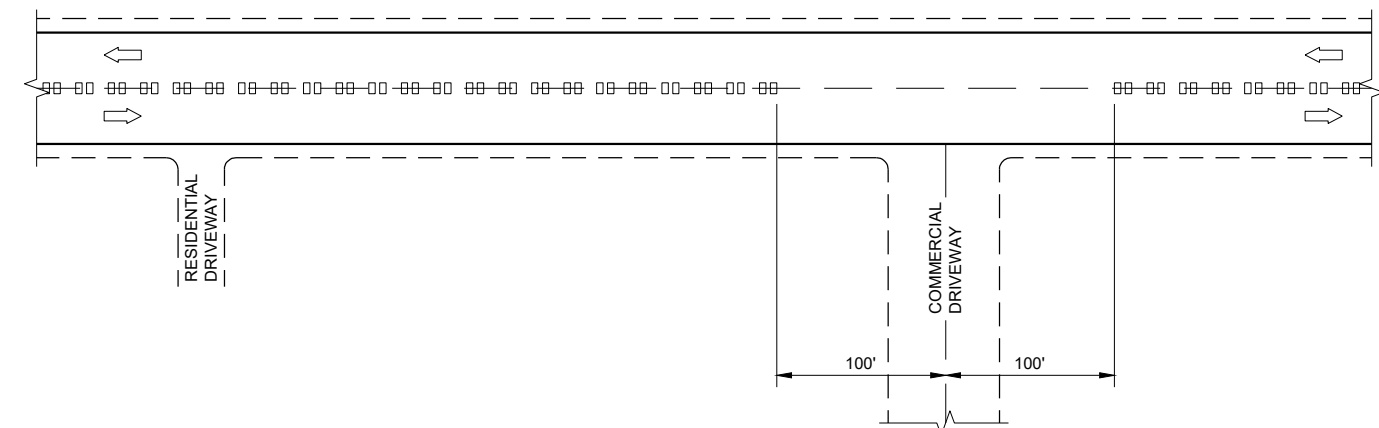

CENTERLINE GROOVES AT DRIVEWAYS^①

GENERAL NOTES

- ① CENTERLINE GROOVES MAY BE OMITTED IN AREAS WITH HIGH CONCENTRATIONS OF DRIVEWAYS. WHEN DIRECTED BY THE ENGINEER.

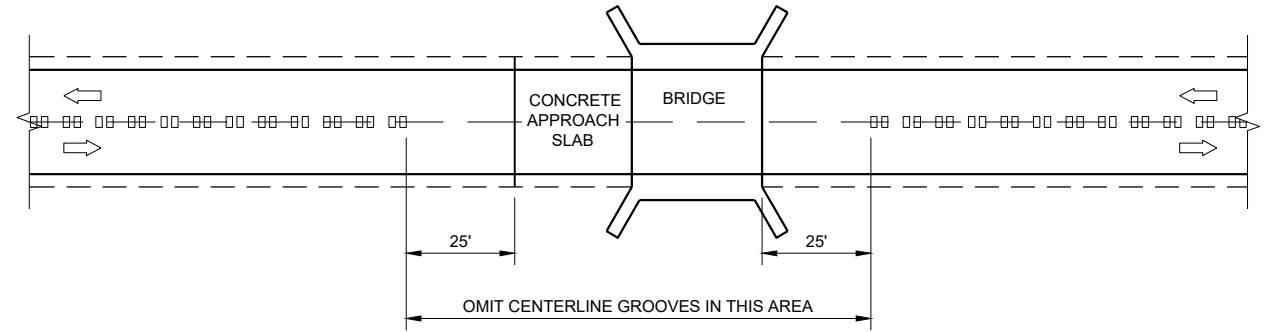

CENTERLINE GROOVES AT BRIDGES

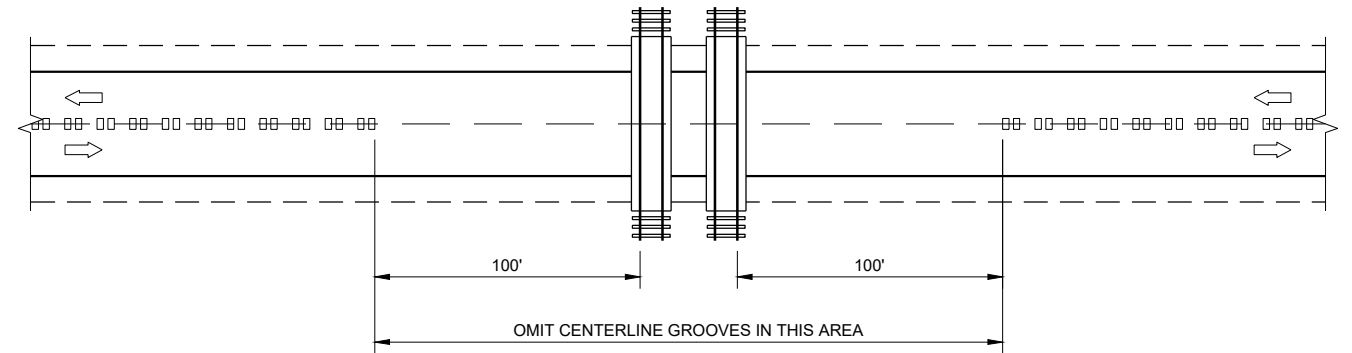

CENTERLINE GROOVES AT RAILROADS

6

6

2-LANE RURAL CENTERLINE RUMBLE STRIP, MILLING	
STATE OF WISCONSIN DEPARTMENT OF TRANSPORTATION	
APPROVED 7/2018 DATE	/S/ Rodney Taylor ROADWAY STANDARDS DEVELOPMENT ENGINEER
FHWA	

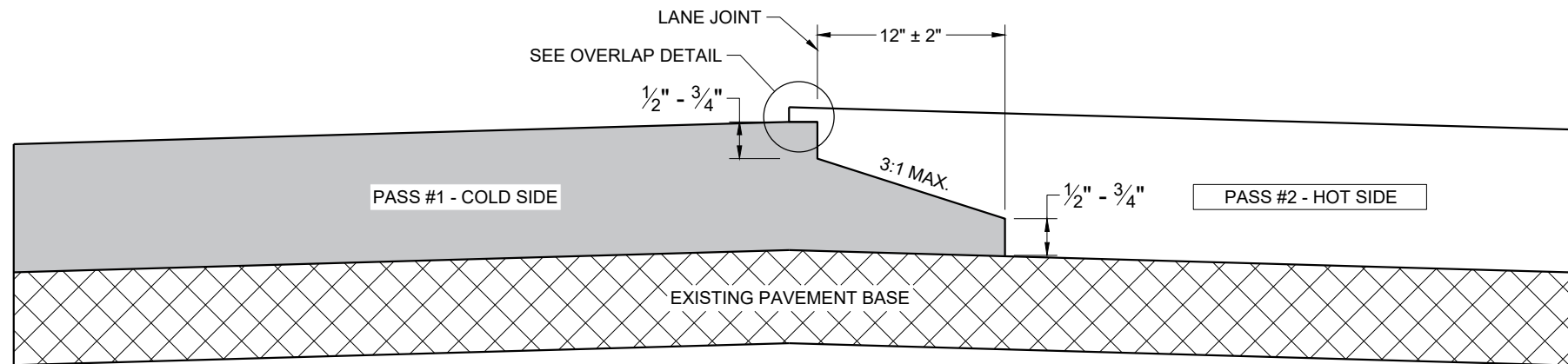

**TYPICAL PAVEMENT CROSS SECTION
NOTCHED WEDGE JOINT**

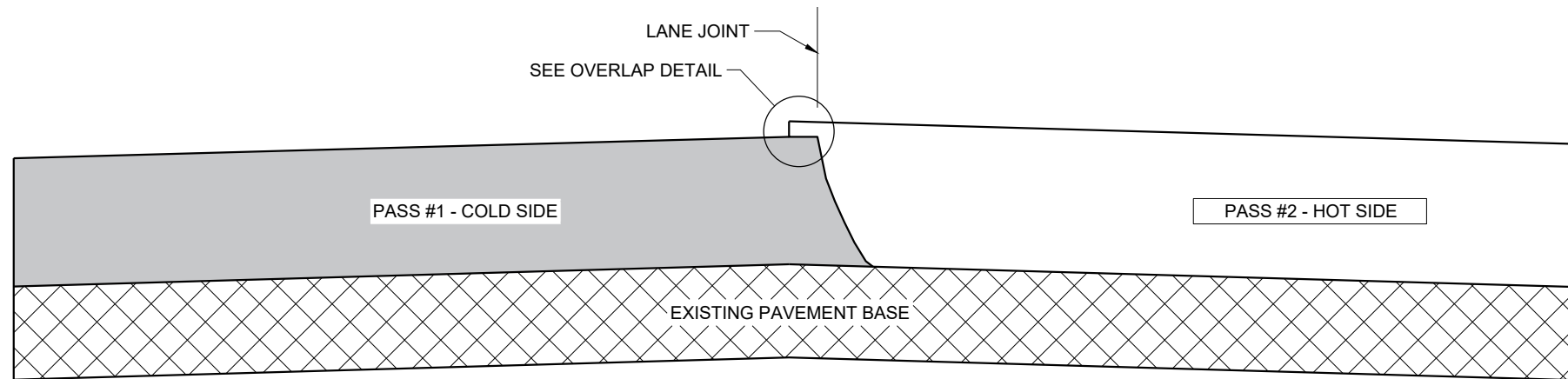

**TYPICAL PAVEMENT CROSS SECTION
VERTICAL JOINT**

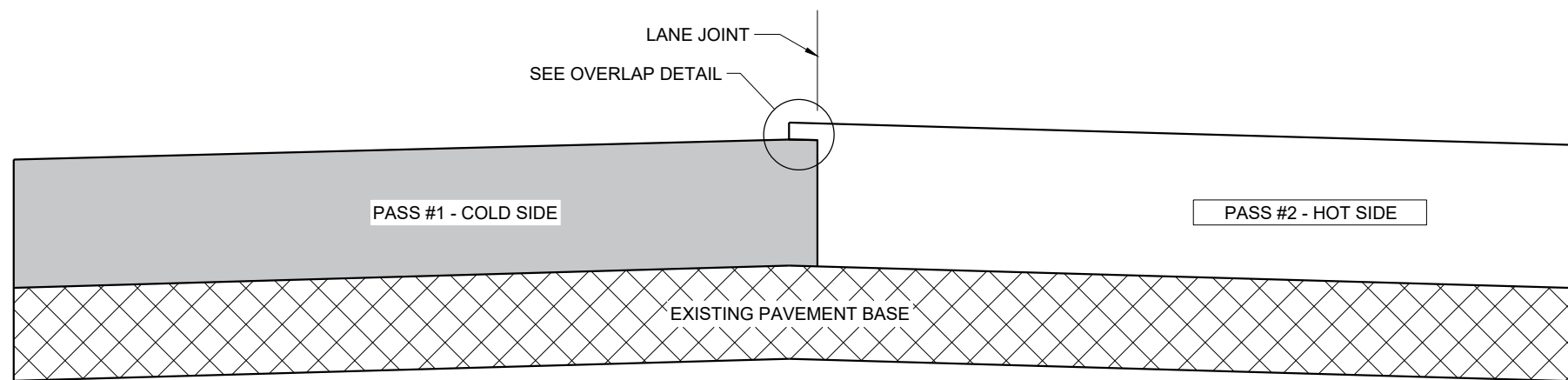

**TYPICAL PAVEMENT CROSS SECTION
VERTICAL JOINT (MILLED)**

GENERAL NOTES

IN ADDITION TO THE DETAILS PROVIDED IN THIS DRAWING, CONFORM TO STANDARD SPECIFICATION 450.3.2.8 FOR WHEN A NOTCHED WEDGE JOINT IS REQUIRED AND FOR GENERAL JOINT CONSTRUCTION REQUIREMENTS.

FOR ALL LONGITUDINAL JOINTS, ENSURE THE PAVER SCREED OVERLAPS THE PREVIOUSLY PLACED PAVEMENT BY $1" \pm 0.5"$ AND THE HOT SIDE OF THE JOINT REMAINS HIGHER THAN THE COLD SIDE BY APPROXIMATELY 0.1" AFTER FINAL COMPACTION. (IT WILL BE FLUSH WHEN PAVING IN ECHELON.)

ONLY REMOVE THE LONGITUDINAL NOTCHED WEDGE JOINT FOR SMA PAVEMENT OR AS DIRECTED BY THE ENGINEER TO ADDRESS SPECIFIC LENGTHS OF JOINT DAMAGED BY TRAFFIC.

WHEN MILLING BACK OR REMOVING ANY LONGITUDINAL JOINT, LIMIT THE MATERIAL REMOVED TO 2" FROM THE TOP NOTCH OR FROM THE VERTICAL JOINT EDGE ON THE COLD SIDE OF THE JOINT.

USE LONGITUDINAL MILLED JOINT AS PLANS SHOW OR THE AS THE ENGINEER DIRECTS.

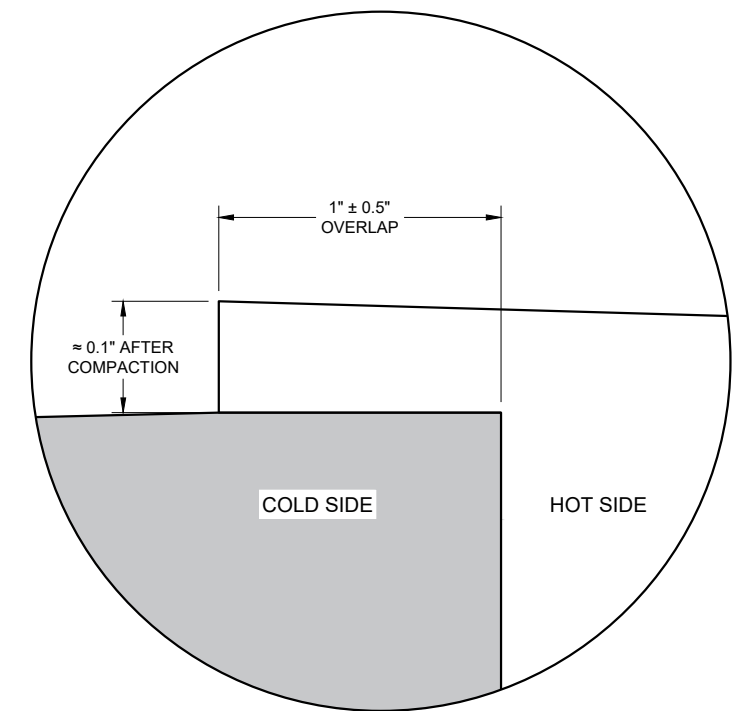

OVERLAP DETAIL (TYPICAL)

6

6

SDD 13C19 - 03

SDD 13C19 - 03

HMA LONGITUDINAL JOINTS	
STATE OF WISCONSIN DEPARTMENT OF TRANSPORTATION	
APPROVED November 2020 DATE	/S/ Steven Hefel HMA PAVEMENT ENGINEER
FHWA	

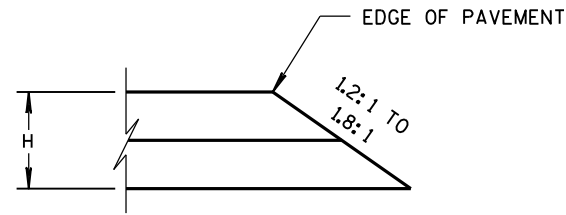

CONSTRUCTED WITH FINAL TWO LAYERS
FOR H 5" OR LESS

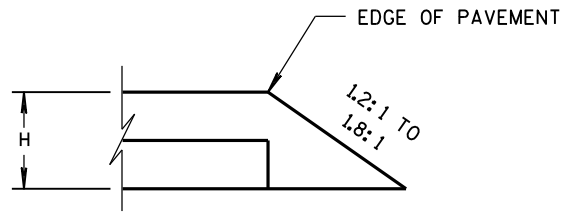

CONSTRUCTED WITH FINAL LAYER
FOR H 5" OR LESS

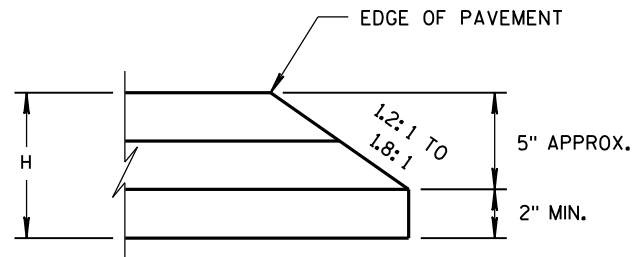

CONSTRUCTED WITH FINAL TWO LAYERS
FOR H GREATER THAN 5"

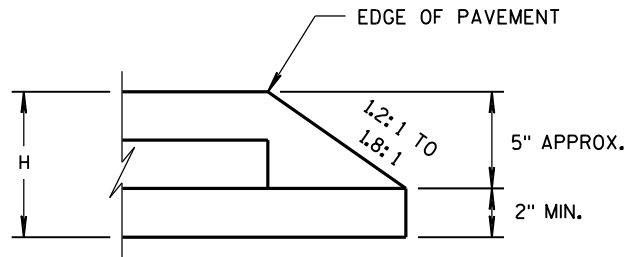

CONSTRUCTED WITH FINAL LAYER
FOR H GREATER THAN 5"

HMA PAVEMENT AND HMA OVERLAYS

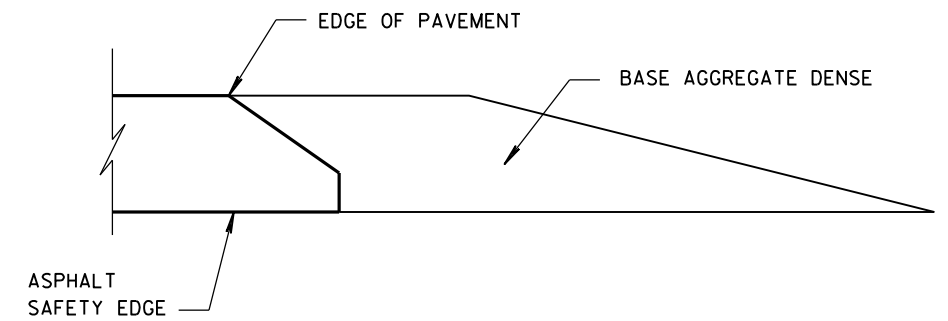

FINISHED SHOULDER AGGREGATE PLACEMENT

6

6

S.D.D. 14 B 29-1

S.D.D. 14 B 29-1

SAFETY EDGE _{SM}	
STATE OF WISCONSIN DEPARTMENT OF TRANSPORTATION	
APPROVED DATE	/s/ Jerry H. Zogg ROADWAY STANDARDS DEVELOPMENT ENGINEER
FHWA	

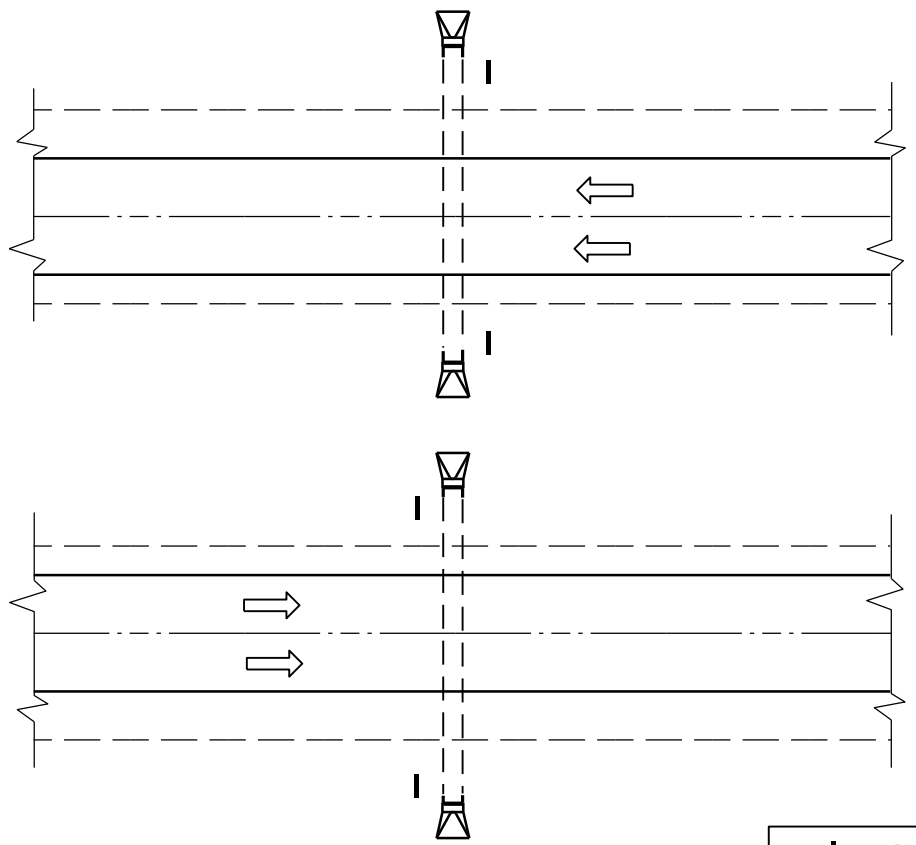

PLAN VIEW
DIVIDED HIGHWAY

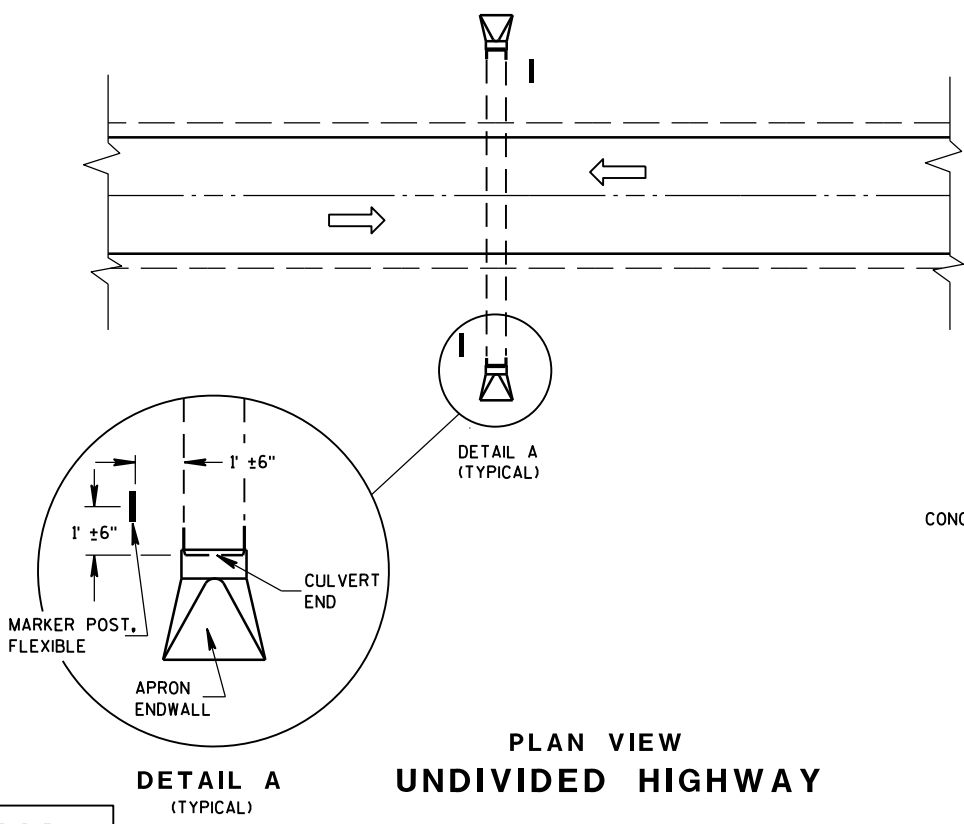

PLAN VIEW
UNDIVIDED HIGHWAY

DETAIL A
(TYPICAL)

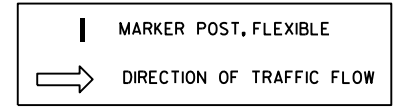

FLEXIBLE MARKER POST LOCATION

GENERAL NOTES

DETAILS OF CONSTRUCTION, MATERIALS AND WORKMANSHIP NOT SHOWN ON THIS DRAWING SHALL CONFORM TO THE PERTINENT REQUIREMENTS OF THE STANDARD SPECIFICATIONS AND THE APPLICABLE SPECIAL PROVISIONS.

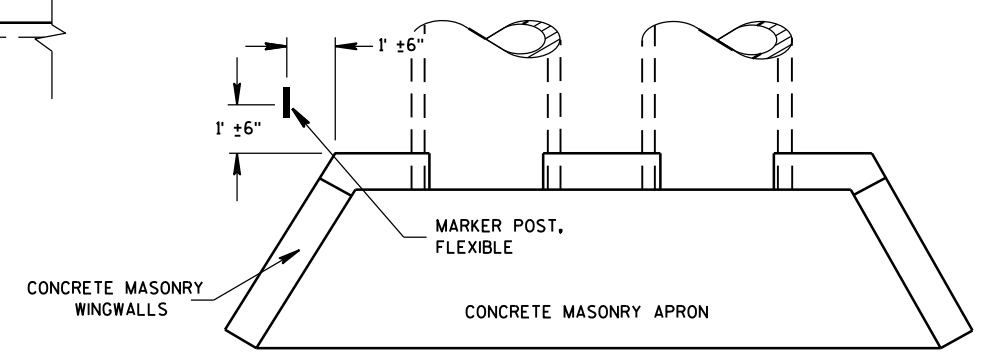

PLAN VIEW
CONCRETE MASONRY ENDWALLS FOR
CULVERT PIPE AND PIPE ARCH

6

6

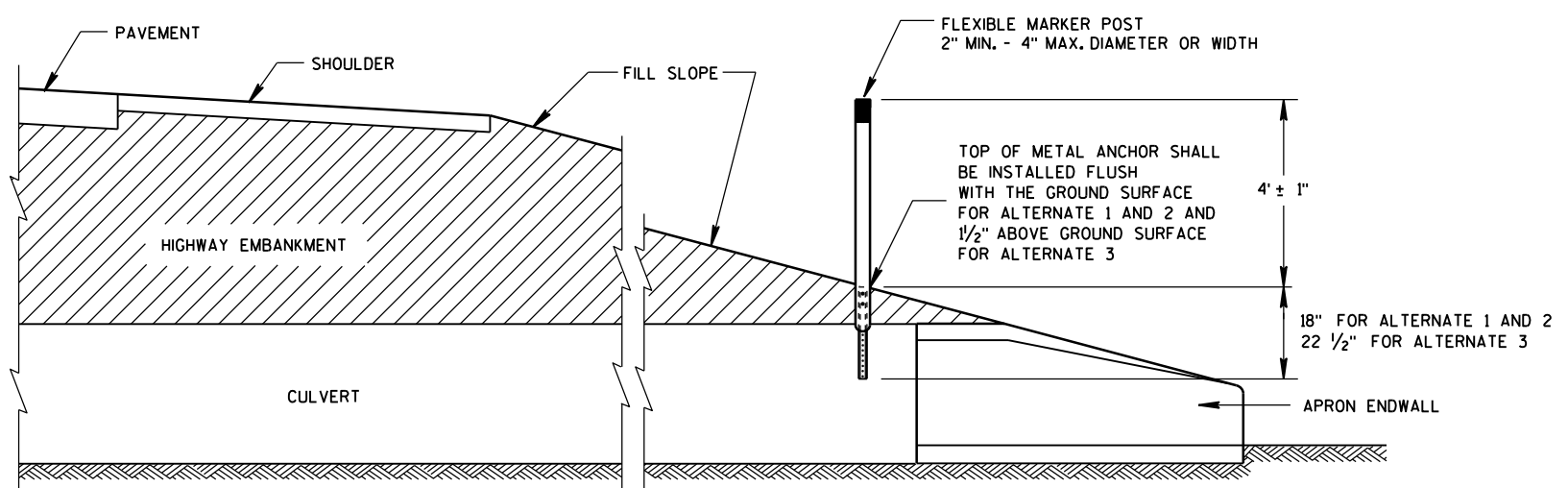

CROSS SECTION
FLEXIBLE MARKER POST

FLEXIBLE MARKER POST
FOR CULVERT END

STATE OF WISCONSIN
DEPARTMENT OF TRANSPORTATION

S.D.D. 15 A 3-2a

S.D.D. 15 A 3-2a

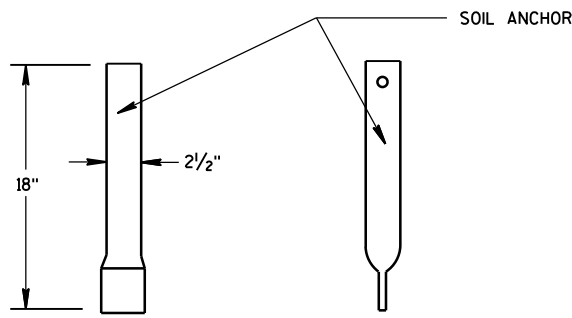
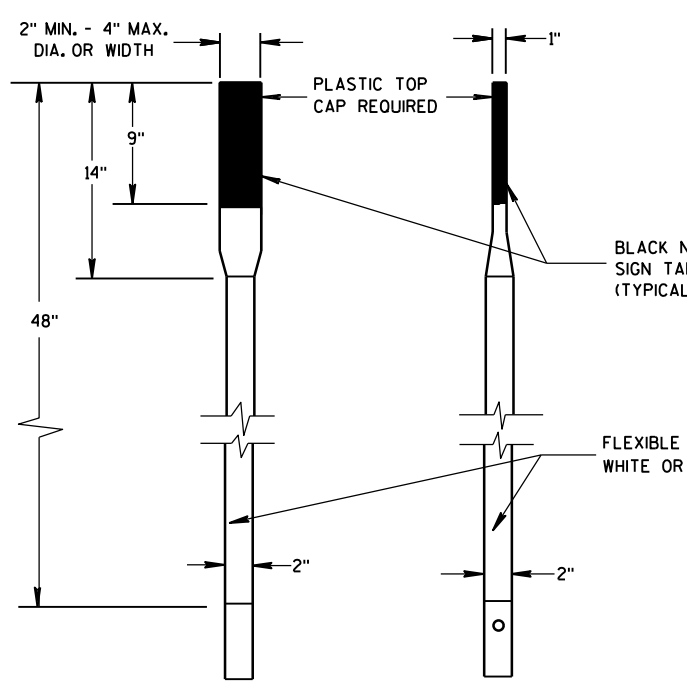

FRONT VIEW SIDE VIEW
ALTERNATE 1

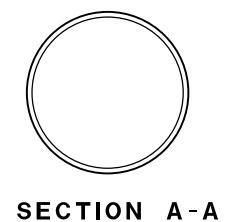

SECTION A-A

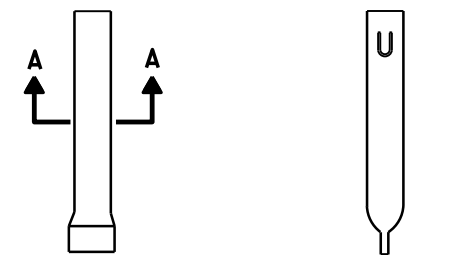

FRONT VIEW SIDE VIEW
ALTERNATE 1

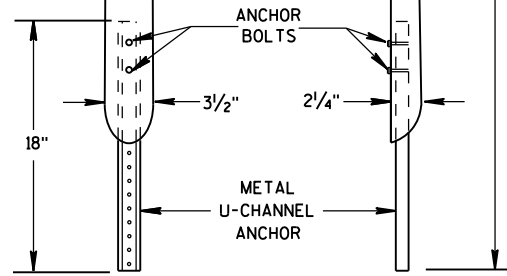
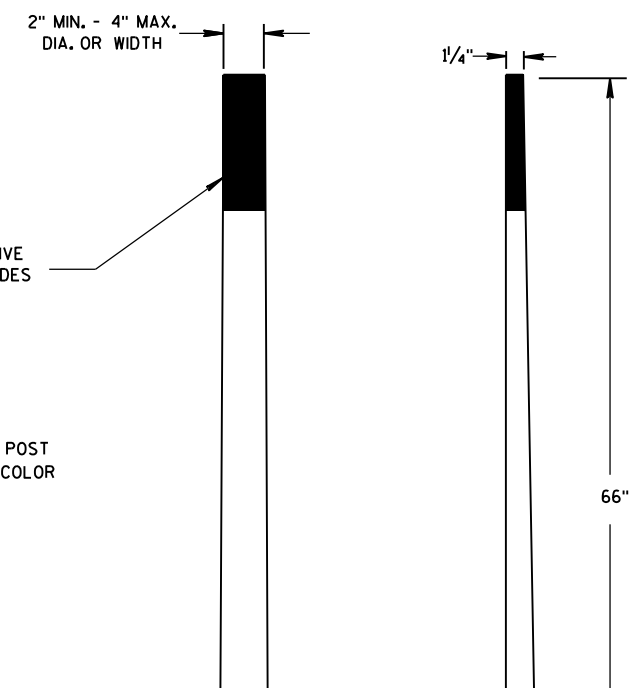

FRONT VIEW SIDE VIEW
ALTERNATE 2

FLEXIBLE MARKER POSTS

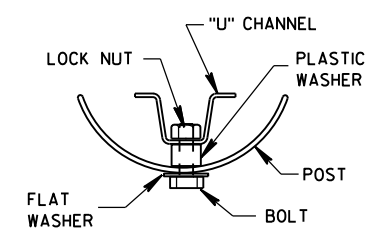

SECTION B-B

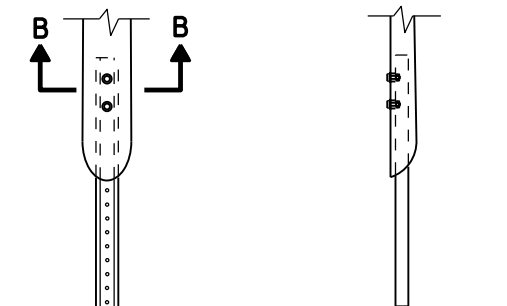

FRONT VIEW SIDE VIEW
ALTERNATE 2

FLEXIBLE MARKER POST ANCHORS

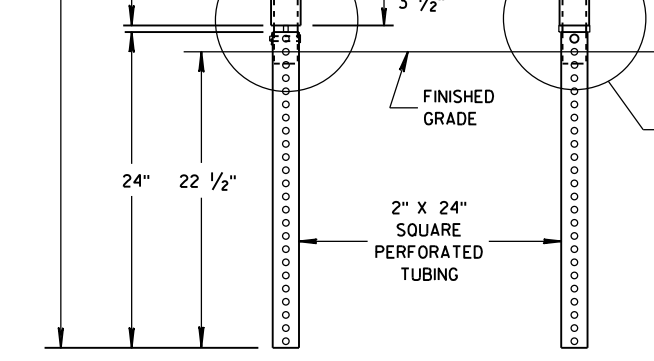
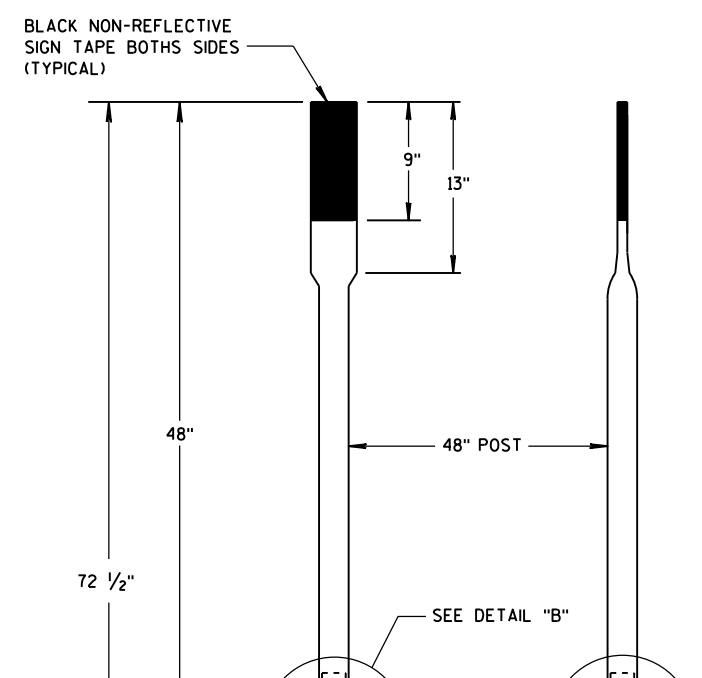

FRONT VIEW SIDE VIEW
ALTERNATE 3

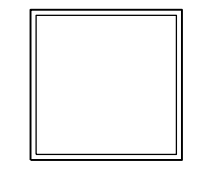

SECTION C-C

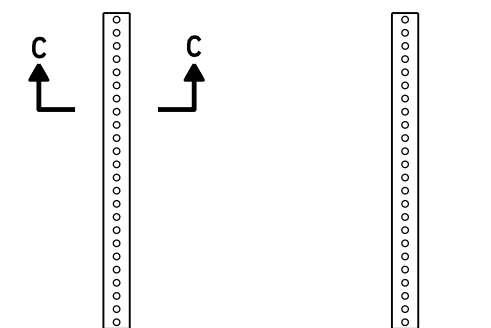

FRONT VIEW SIDE VIEW
ALTERNATE 3

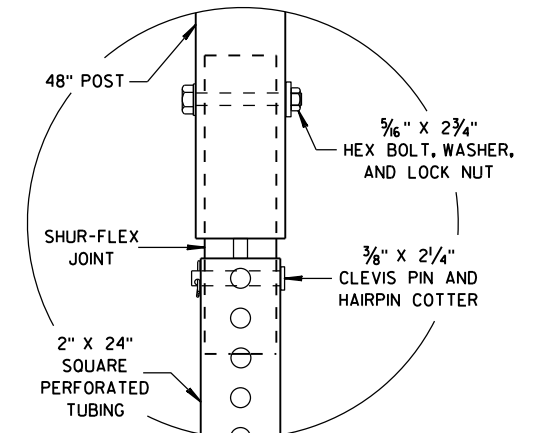

DETAIL B

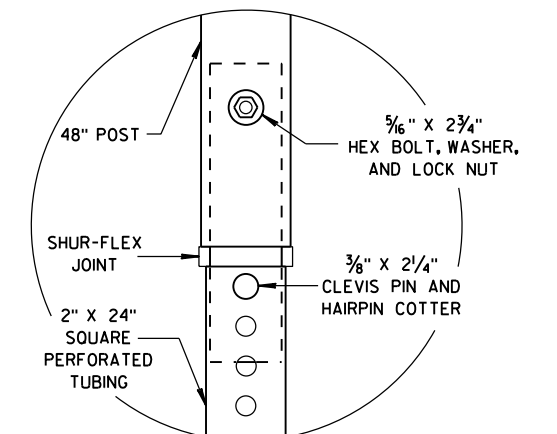

DETAIL C

FLEXIBLE MARKER POST FOR CULVERT END

STATE OF WISCONSIN
DEPARTMENT OF TRANSPORTATION

APPROVED
10/1/2012 DATE /S/ Travis Feltes
STATE TRAFFIC ENGINEER OF DESIGN
FHWA

GENERAL NOTES

THE EXACT NUMBER, LOCATION, AND SPACING OF ALL SIGNS AND DEVICES SHALL BE ADJUSTED TO FIT FIELD CONDITIONS.

THE SPACING BETWEEN TRAFFIC CONTROL SIGNS SHOULD BE ADJUSTED TO NOT CONFLICT WITH AND SHOULD PROVIDE A MINIMUM OF 200 FEET (500 FEET DESIRABLE) CLEARANCE TO EXISTING SIGNS THAT WILL REMAIN IN PLACE.



ALL SIGNS ARE 48" X 48" UNLESS OTHERWISE NOTED.

SIGNS THAT WILL BE IN PLACE LESS THAN SEVEN CONTINUOUS DAYS AND NIGHTS MAY BE MOUNTED ON PORTABLE SUPPORTS.

IF A "STOP" SIGN MUST BE REMOVED FOR A WORK OPERATION, A TEMPORARY "STOP" SIGN SHALL BE PLACED PRIOR TO THE SIGN REMOVAL, OR A FLAGGER SHALL BE PROVIDED UNTIL THE SIGN IS REESTABLISHED.

- * OMIT G20-1 SIGNS IF LENGTH OF WORK AREA IS 2 MILES OR LESS
- ** PLACE AN ADDITIONAL W20-1A "ROAD WORK AHEAD" SIGN IF WORK AREA WITHIN THE PROJECT IS SEPARATED BY MORE THAN 2 MILES FROM PREVIOUS WORK AREA.

LEGEND

-  SIGN ON PERMANENT SUPPORT
-  DIRECTION OF TRAFFIC
-  WORK AREA

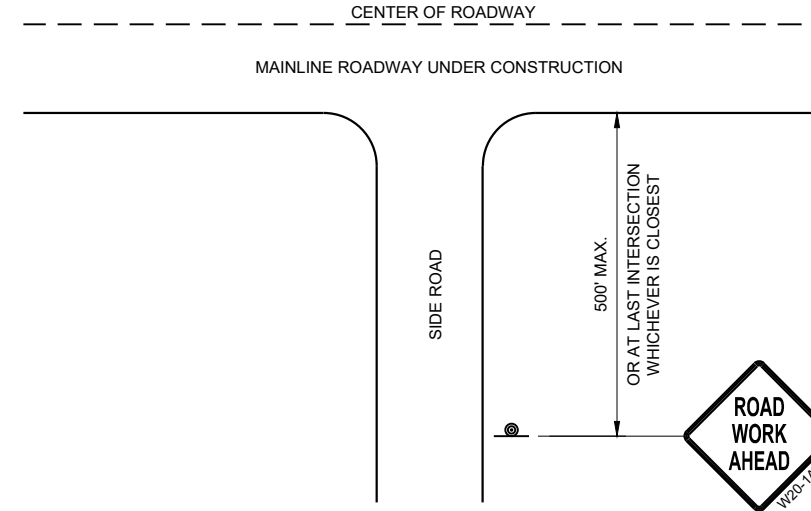

TYPICAL SIDE ROAD APPROACH WARNING SIGN DETAIL

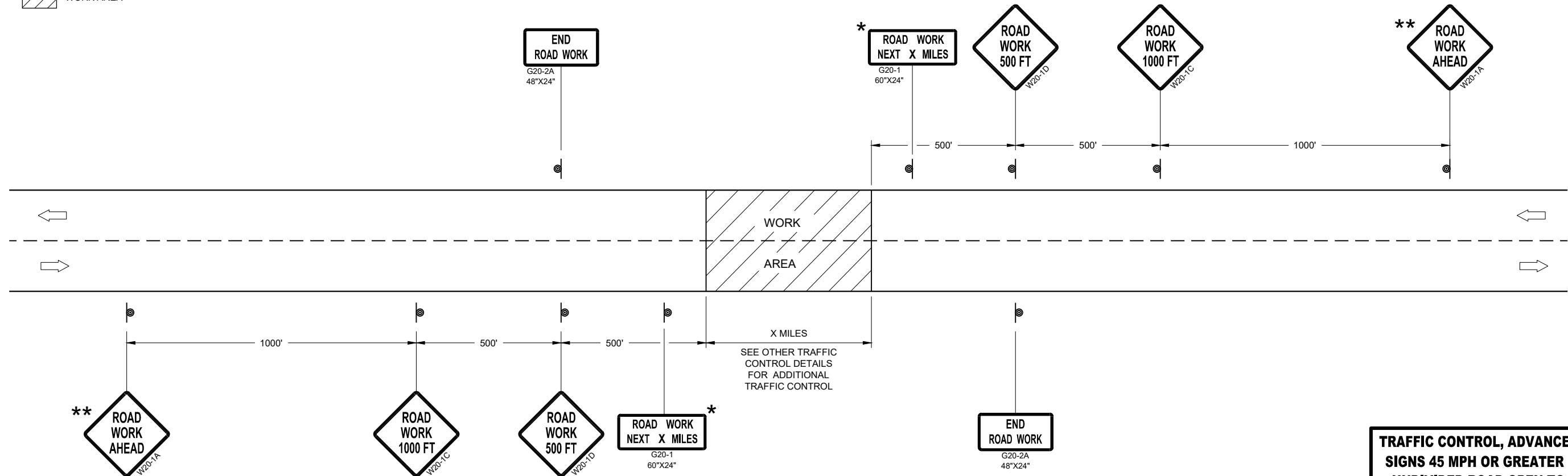

TRAFFIC CONTROL, ADVANCE WARNING SIGNS 45MPH OR GREATER

TRAFFIC CONTROL, ADVANCE WARNING SIGNS 45 MPH OR GREATER TWO-WAY UNDIVIDED ROAD OPEN TO TRAFFIC

STATE OF WISCONSIN
DEPARTMENT OF TRANSPORTATION

APPROVED
DATE July 2018 /S/ Andrew Heidtke
WORK ZONE ENGINEER

FHWA

GENERAL NOTES

DETAILS OF INSTALLATION, MATERIALS AND WORKMANSHIP NOT SHOWN ON THIS DRAWING SHALL CONFORM TO THE PERTINENT REQUIREMENTS OF THE STANDARD SPECIFICATIONS AND APPLICABLE SPECIAL PROVISIONS.

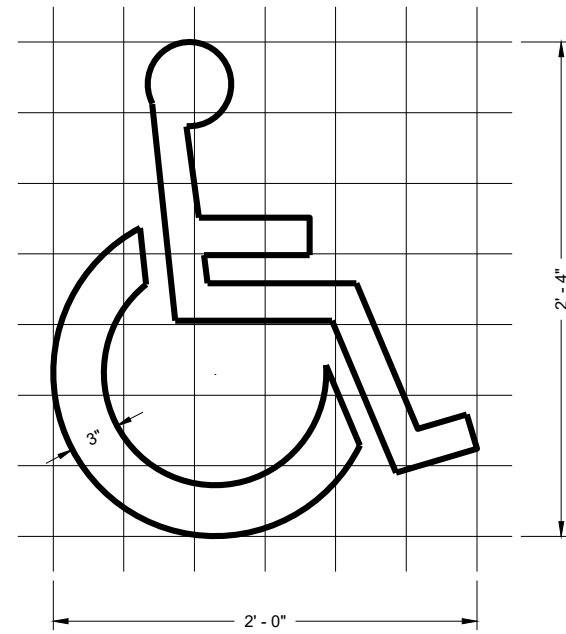

HANDICAP SYMBOL

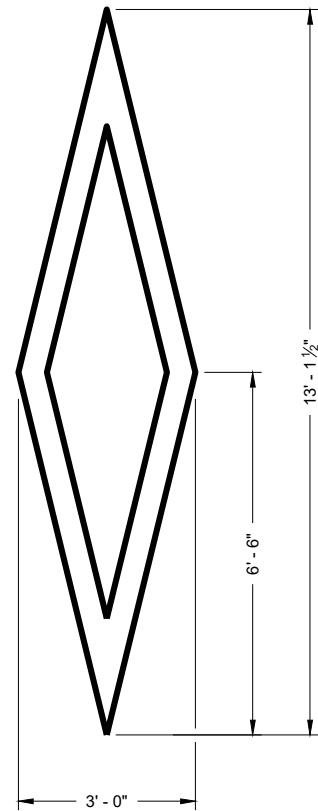

**PREFERENTIAL
LANE SYMBOL**

PAVEMENT MARKING SYMBOLS

STATE OF WISCONSIN
DEPARTMENT OF TRANSPORTATION

APPROVED
November 2019 /S/ Matthew Rauch
DATE STATE SIGNING AND MARKING
ENGINEER

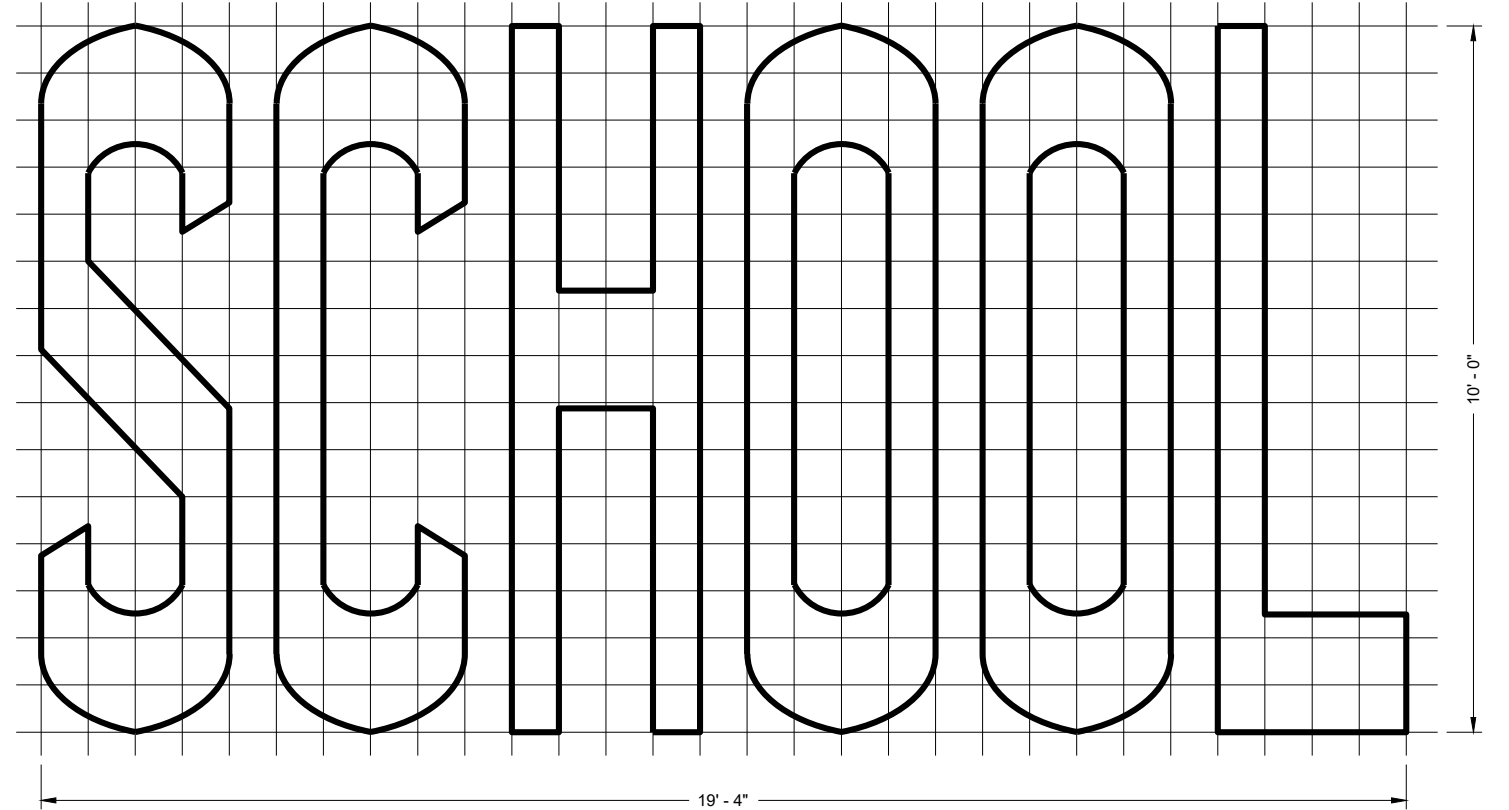
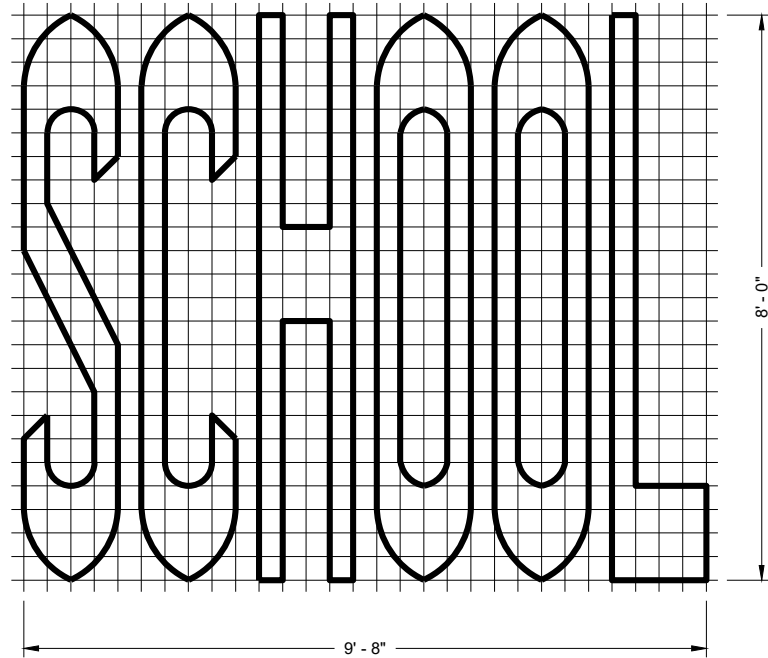
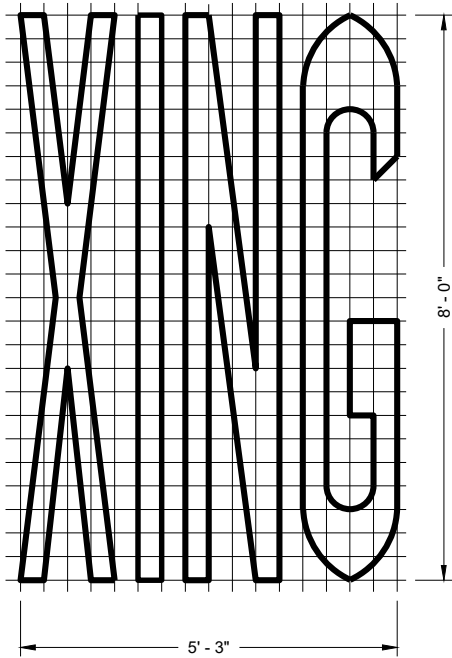
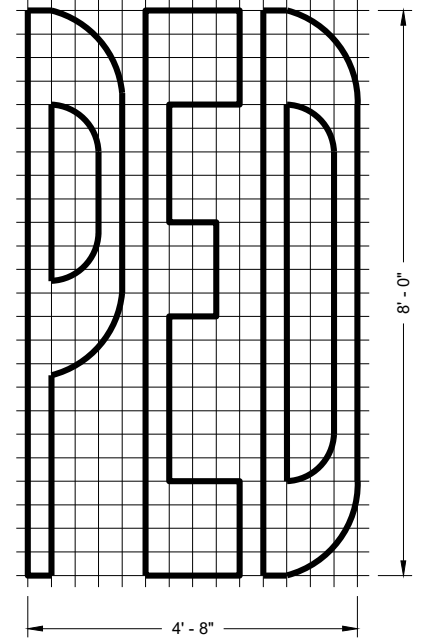
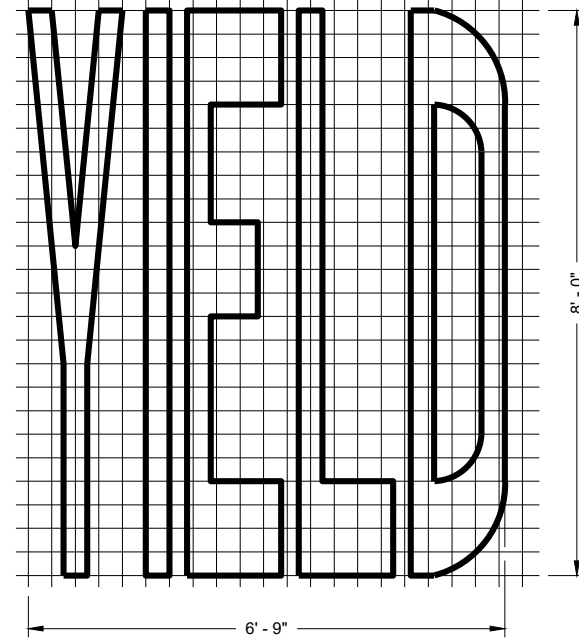
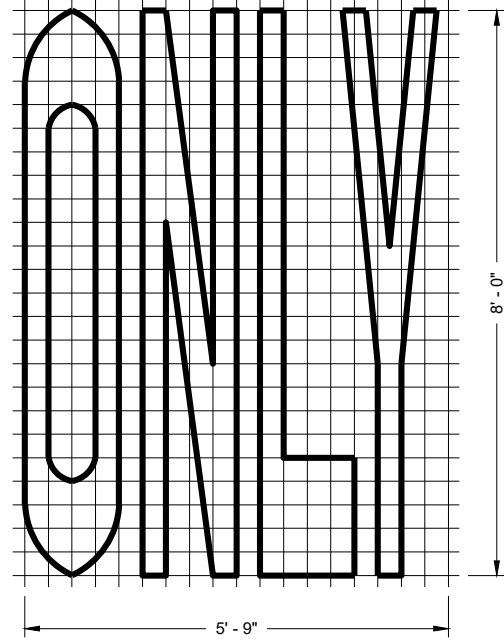
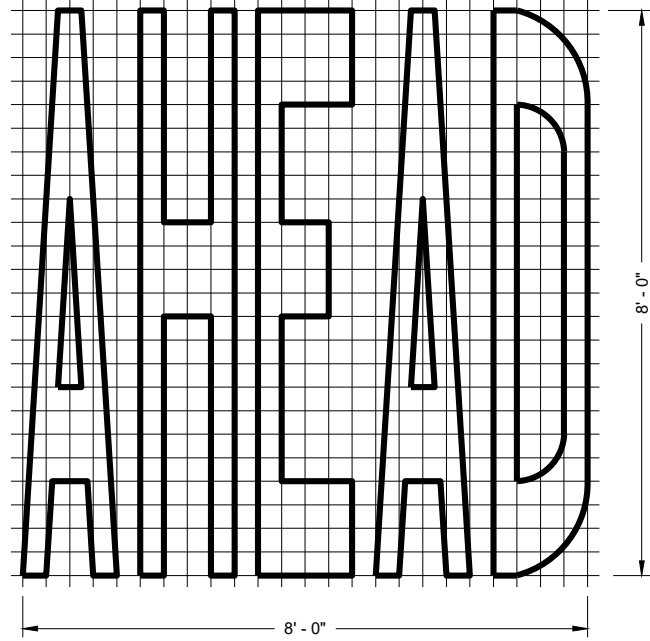
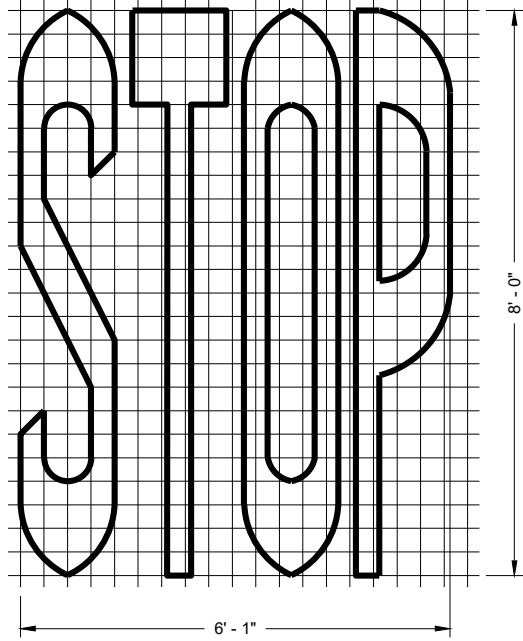

SINGLE LANE

TWO - LANE

GENERAL NOTES

DETAILS OF INSTALLATION, MATERIALS AND WORKMANSHIP NOT SHOWN ON THIS DRAWING SHALL CONFORM TO THE PERTINENT REQUIREMENTS OF THE STANDARD SPECIFICATIONS AND APPLICABLE SPECIAL PROVISIONS.

PAVEMENT MARKING WORDS

STATE OF WISCONSIN
DEPARTMENT OF TRANSPORTATION

APPROVED
November 2019 /S/ Matthew Rauch
DATE STATE SIGNING AND MARKING
ENGINEER

FHWA

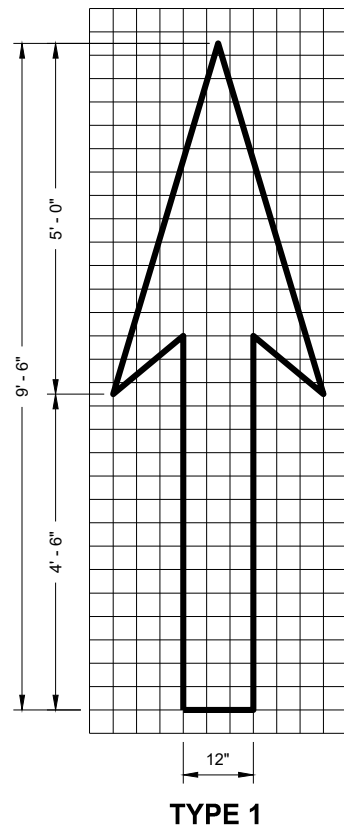

TYPE 1

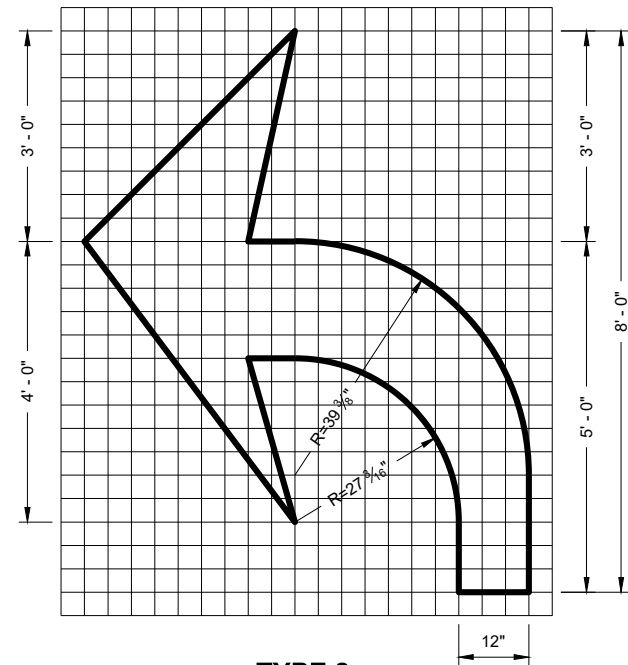

TYPE 2

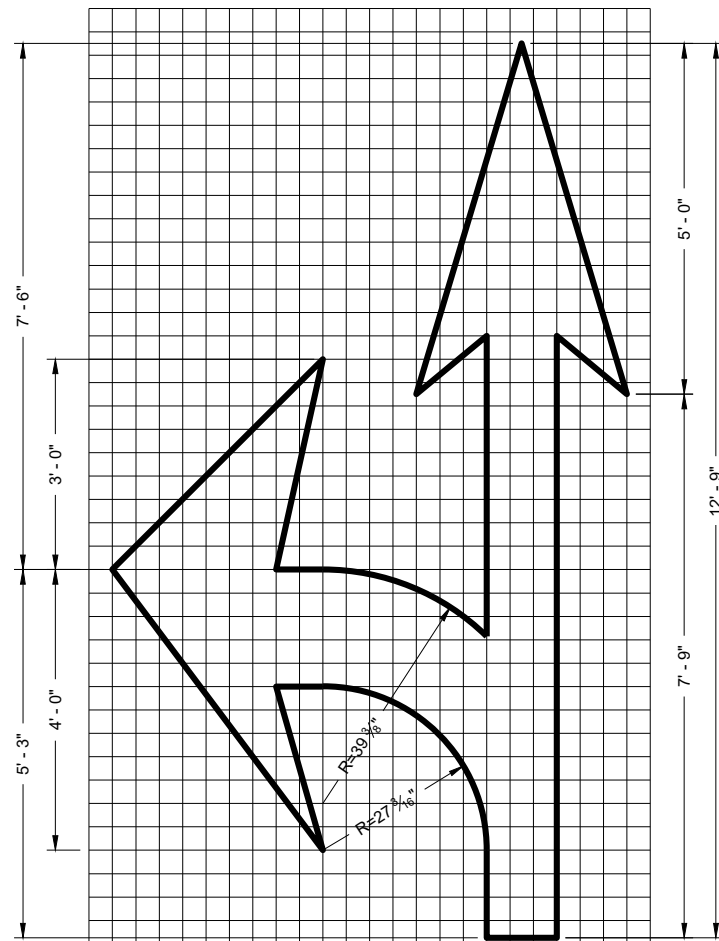

TYPE 3

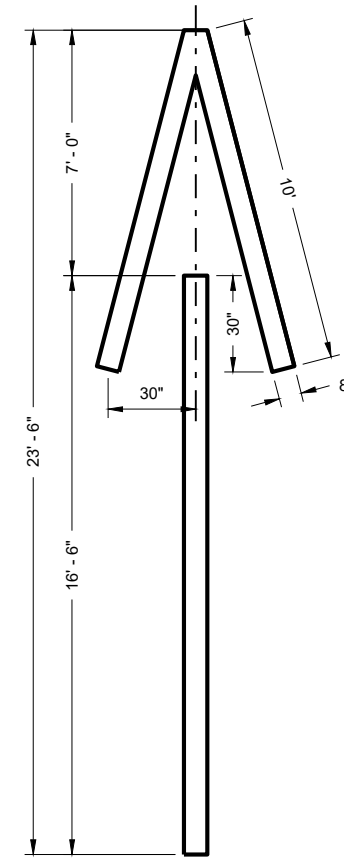

TYPE 4

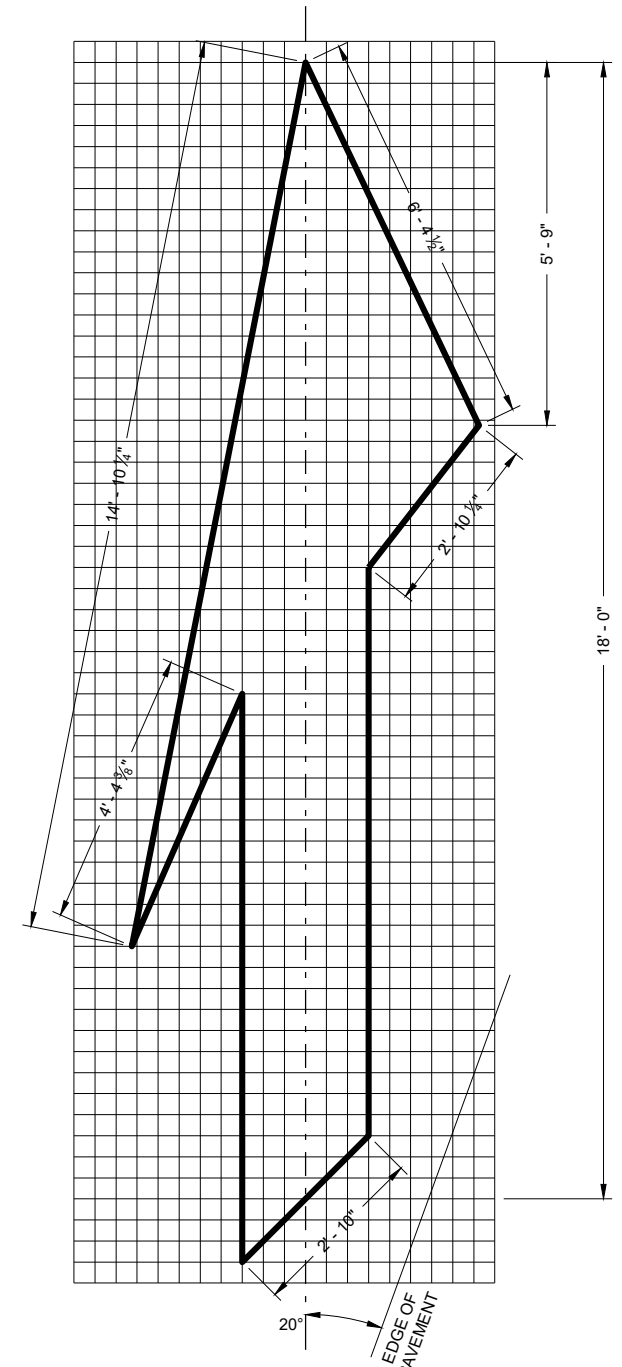

TYPE 5 LANE DROP ARROW

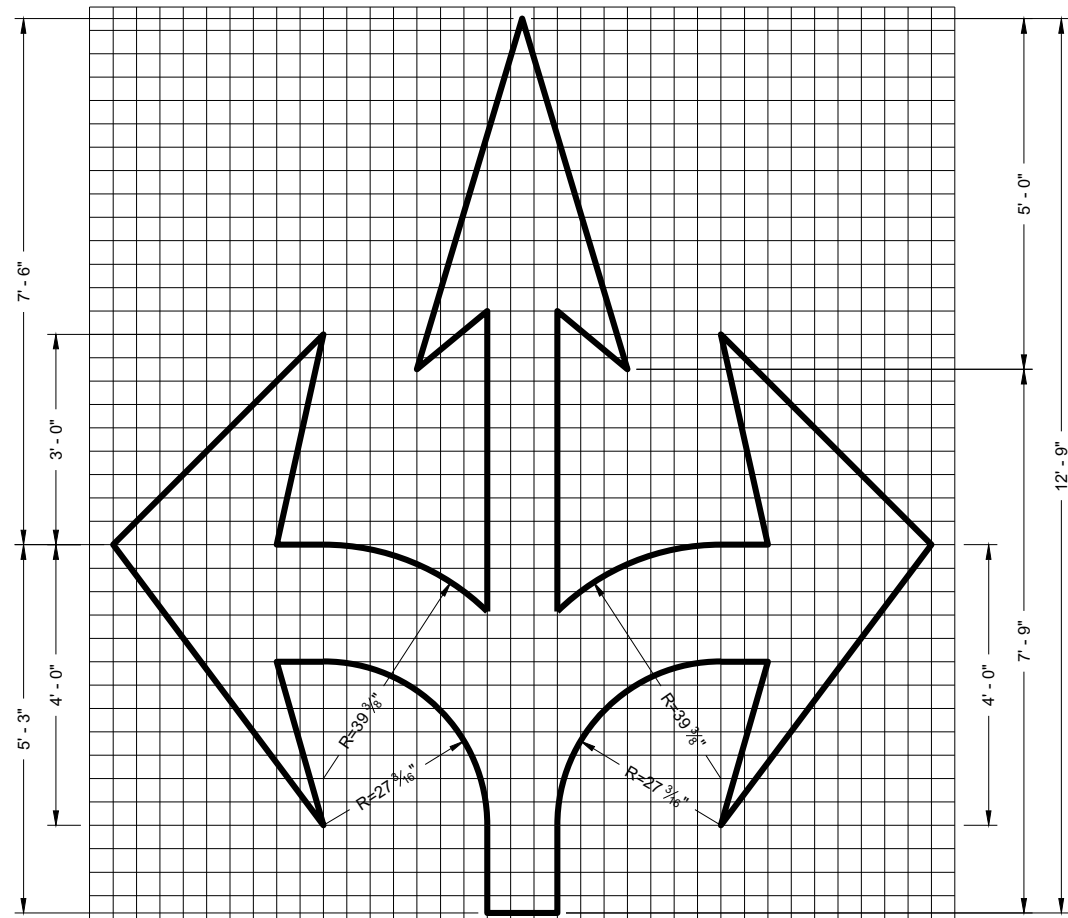

TYPE 6

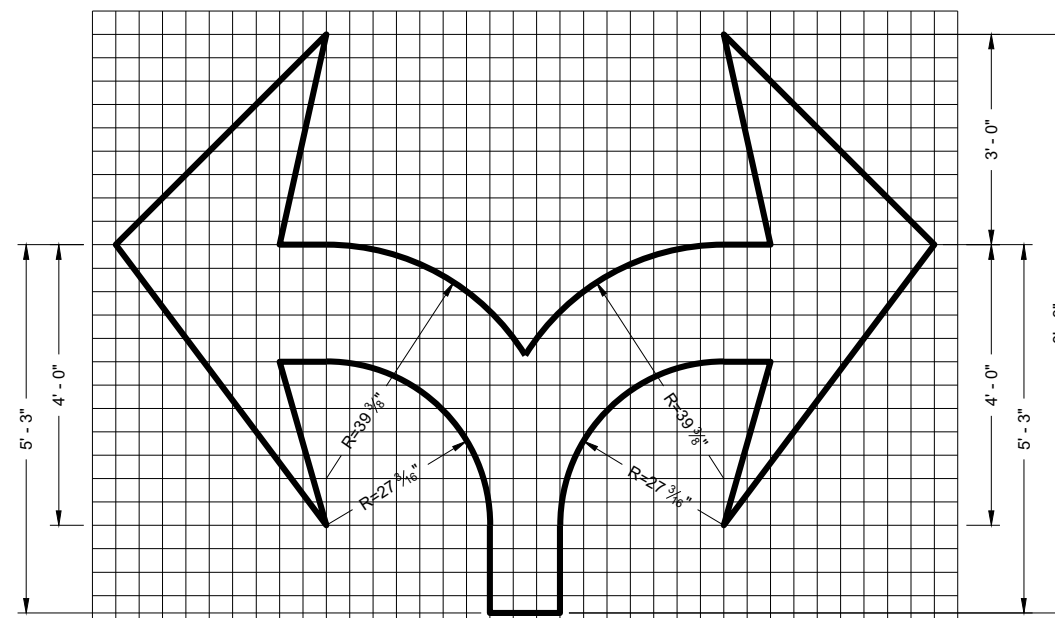

TYPE 7

GENERAL NOTES

DETAILS OF INSTALLATION, MATERIALS AND WORKMANSHIP NOT SHOWN ON THIS DRAWING SHALL CONFORM TO THE PERTINENT REQUIREMENTS OF THE STANDARD SPECIFICATIONS AND APPLICABLE SPECIAL PROVISIONS.

PAVEMENT MARKING ARROWS

STATE OF WISCONSIN
DEPARTMENT OF TRANSPORTATION

APPROVED

November 2019

DATE

FHWA



/s/ Matthew Rauch
STATE SIGNING AND MARKING
ENGINEER

GENERAL NOTES

DETAILS OF CONSTRUCTION NOT SHOWN ON THIS DRAWING SHALL CONFORM TO STANDARD SPECIFICATIONS AND SPECIAL PROVISIONS.

- ① LOCATE THE NO PASSING ZONE W14-3 SIGN WITHIN 50 FEET OF THE "T" MARKING
- ② MEASURE FROM EDGE OF MARKING TO JOINT LINE. THIS DOES NOT INCLUDE SPACE NEEDED FOR GROOVING OPERATIONS.

LEGEND

-  "T" MARKING
-  SIGN ON PERMANENT SUPPORT
-  DIRECTION OF TRAFFIC

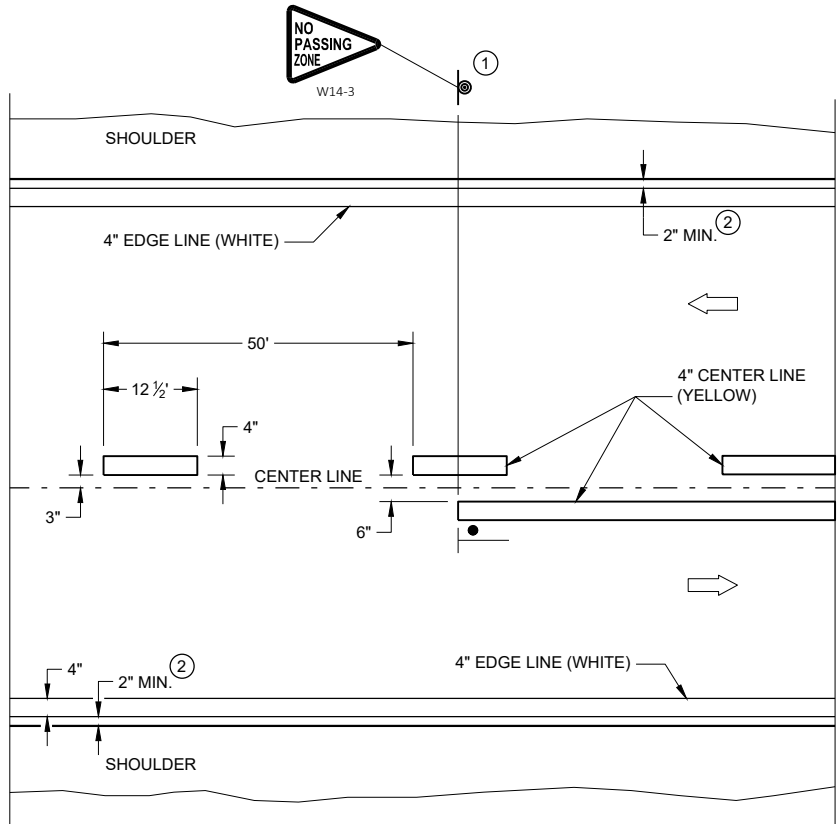

TWO WAY TRAFFIC

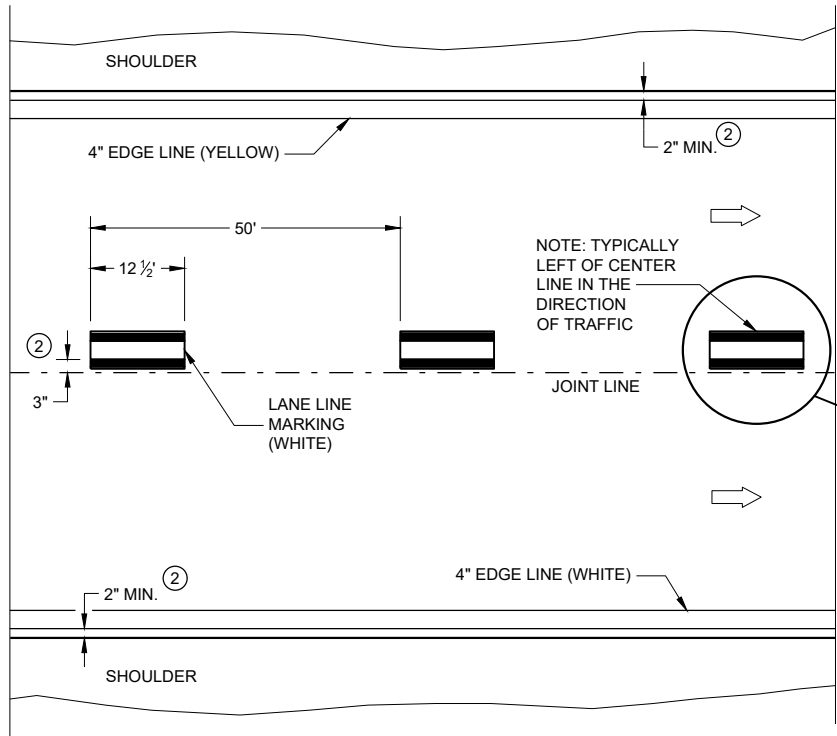

ONE WAY TRAFFIC

PERMANENT PAVEMENT MARKING

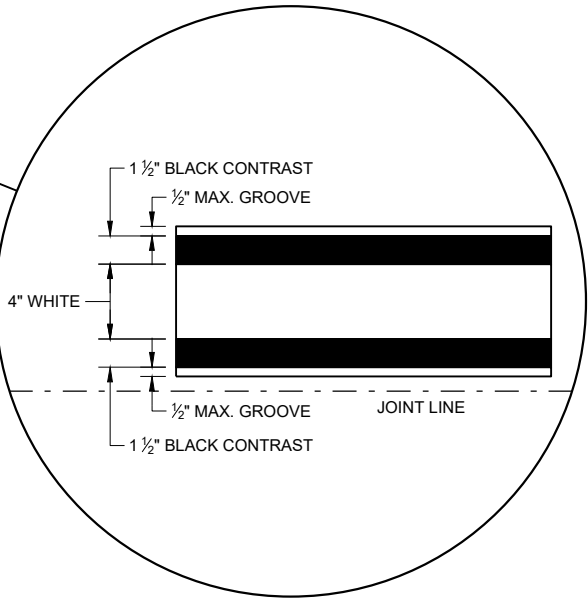

6

6

SDD 15C08 - 21a

SDD 15C08 - 21a

PERMANENT LONGITUDINAL PAVEMENT MARKINGS

STATE OF WISCONSIN
DEPARTMENT OF TRANSPORTATION

APPROVED
DATE: May 2022 /S/ Jeannie Silver
STATEWIDE SIGNING AND MARKING ENGINEER

FHWA

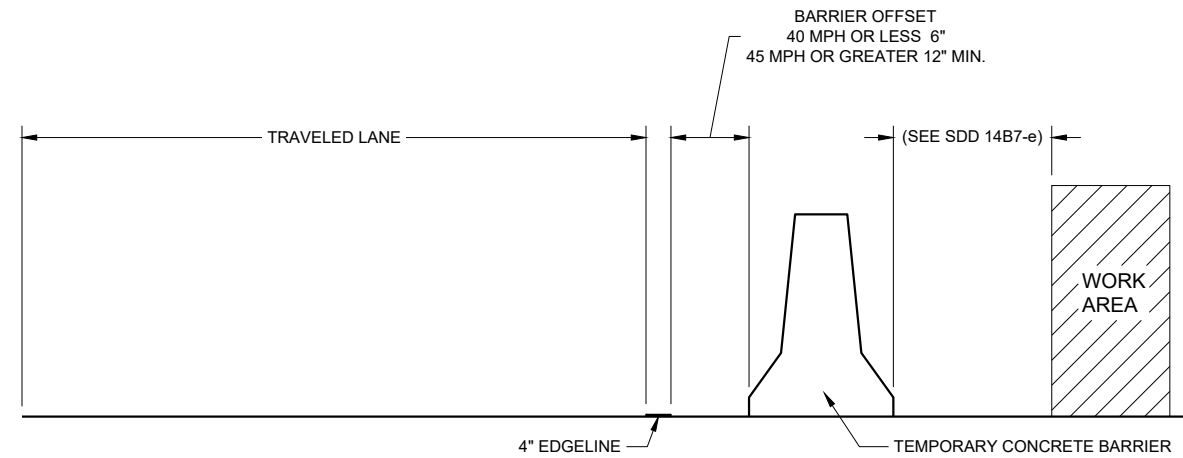

TEMPORARY BARRIER OFFSET FROM EDGELINE

GENERAL NOTES

DETAILS OF CONSTRUCTION NOT SHOWN ON THIS DRAWING SHALL CONFORM TO STANDARD SPECIFICATIONS AND SPECIAL PROVISIONS.

LEGEND

➡ DIRECTION OF TRAFFIC

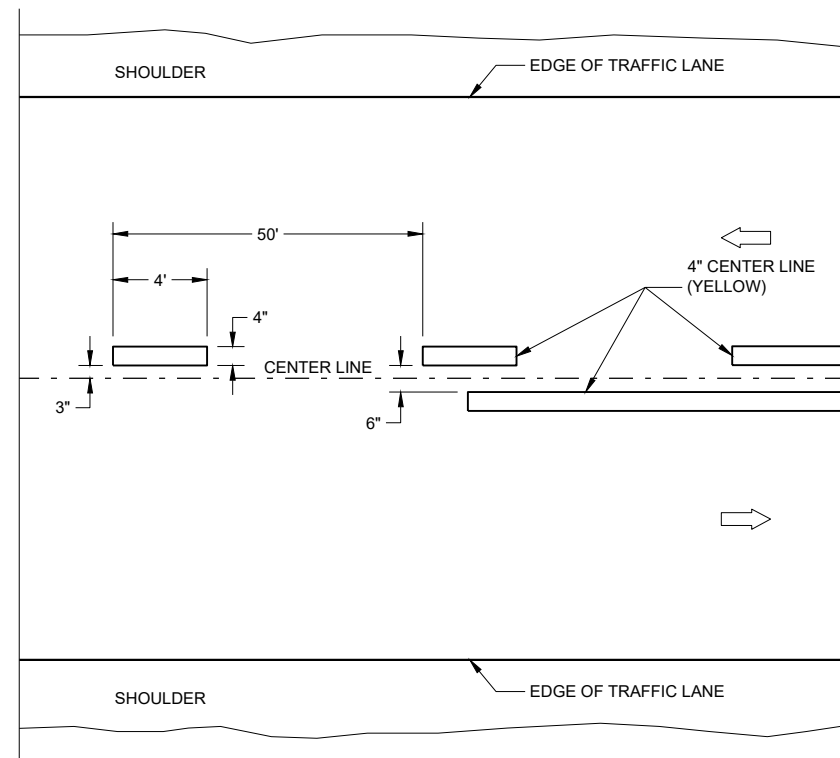

TWO WAY TRAFFIC

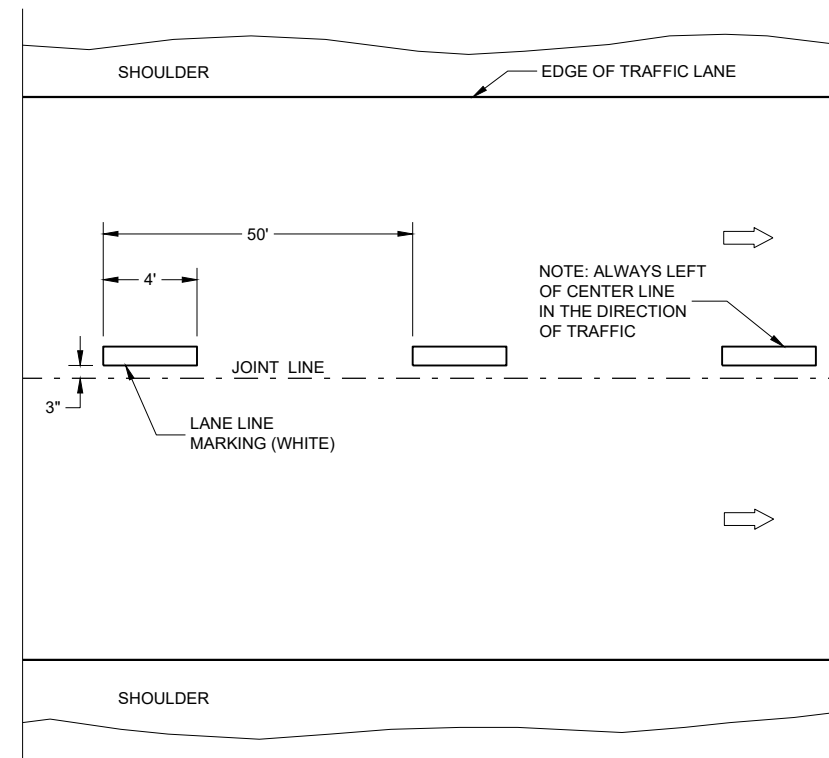

ONE WAY TRAFFIC

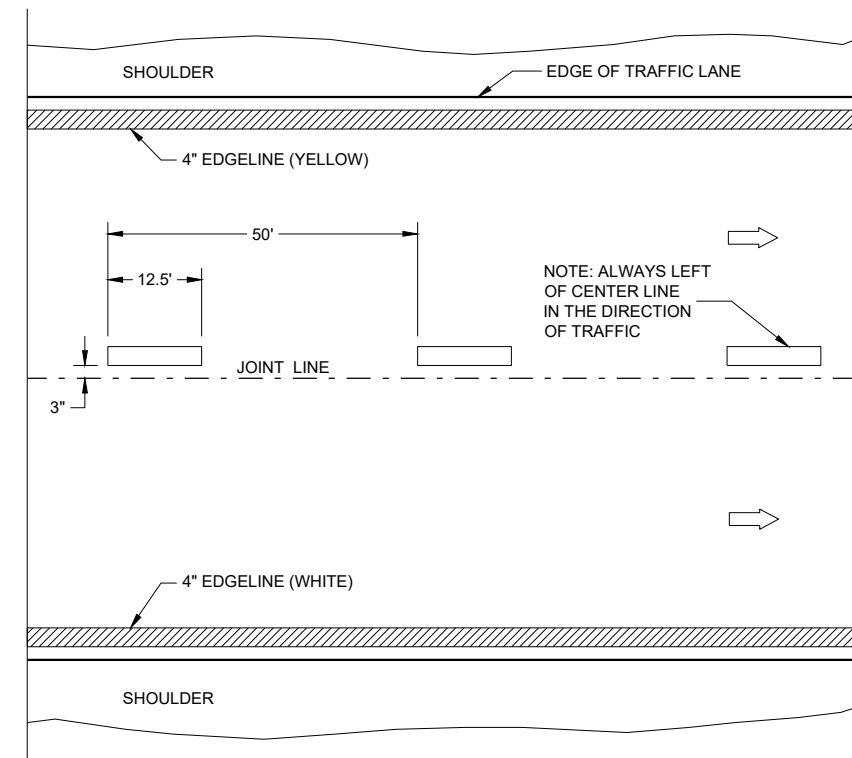

FREEWAYS AND EXPRESSWAYS

TEMPORARY PAVEMENT MARKING

TEMPORARY LONGITUDINAL PAVEMENT MARKING

STATE OF WISCONSIN
DEPARTMENT OF TRANSPORTATION

APPROVED
May 2022 DATE /S/ Jeannie Silver
STATEWIDE SIGNING AND MARKING ENGINEER

FHWA

GENERAL NOTES

- ① A SET OF ARROWS IS REQUIRED EVERY 400 FEET OR NEAR INTERSECTIONS OR DRIVEWAYS WITH TURNING TRAFFIC.
- ② 8" WHITE
- ③ TURN BAY LENGTH OF LESS THAN 48' DOES NOT REQUIRE PAVEMENT ARROWS OR TEXT.

➡ DIRECTION OF TRAFFIC

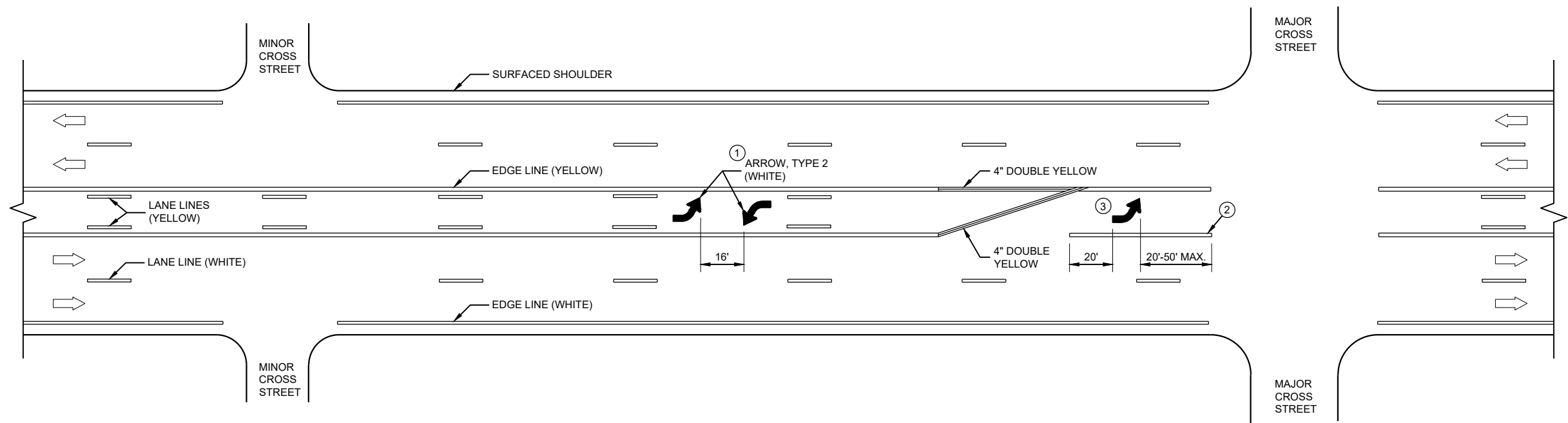

TWO WAY LEFT TURN LANE

6

6

SDD 15C08 - 21c

SDD 15C08 - 21c

<p>PAVEMENT MARKING (TURN LANES)</p>
<p>STATE OF WISCONSIN DEPARTMENT OF TRANSPORTATION</p>

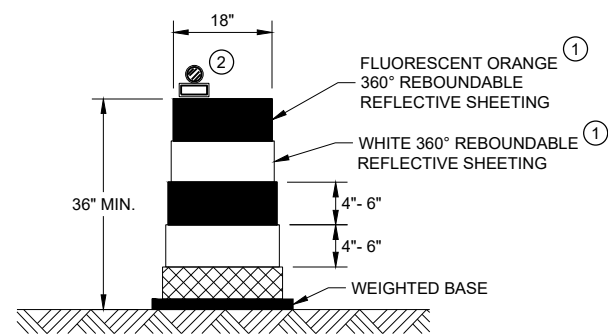

DRUM

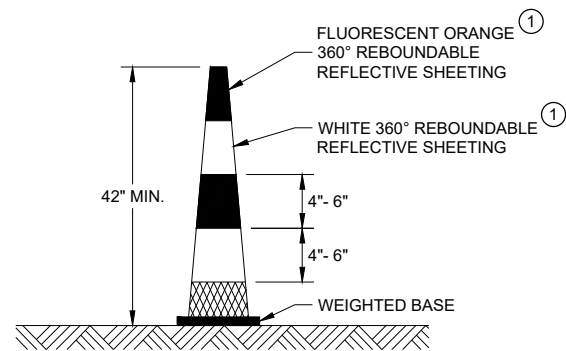

42" CONE

DO NOT USE IN TAPERS
1/2 SPACING OF DRUMS

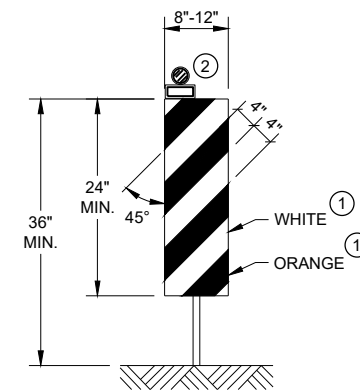

VERTICAL PANEL

THE STRIPES SHALL SLOPE DOWNWARD TO THE TRAFFIC SIDE FOR CHANNELIZATION.

GENERAL NOTES

- ① REFLECTIVE SHEETING SHALL FOLLOW THE REQUIREMENTS IN THE APPROVED PRODUCTS LISTING FOR SIGN SHEETING.
- ② LOCATION OF WARNING LIGHTS WHEN SHOWN ON THE PLAN.

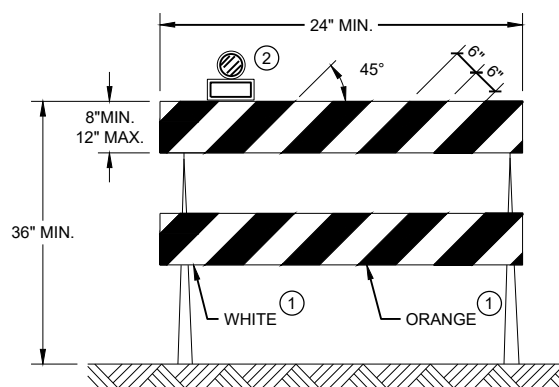

TYPE II BARRICADE

FOR RAILS LESS THAN 36" LONG, 4" WIDE STRIPES MAY BE USED. ALL STRIPES SHALL SLOPE DOWNWARD TO THE TRAFFIC SIDE FOR CHANNELIZATION.

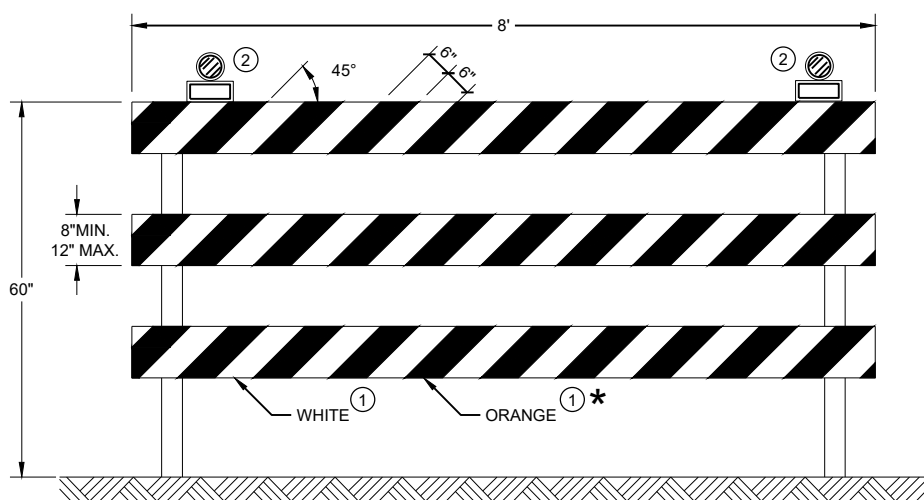

TYPE III BARRICADE

IF SIGN MOUNTED, DO NOT COVER MORE THAN 50% OF THE TOP TWO RAILS OR 33% OF THE TOTAL AREA OF THE THREE RAILS.





* IF USED FOR A PERMANENT APPLICATION USE RED SHEETING.

**CHANNELIZING DEVICES
DRUMS, CONES, BARRICADES
AND VERTICAL PANELS**

STATE OF WISCONSIN
DEPARTMENT OF TRANSPORTATION

APPROVED
May 2021 /S/ Andrew Heidtke
DATE WORK ZONE ENGINEER

LEGEND

-  SIGN ON PORTABLE OR PERMANENT SUPPORT
-  TEMPORARY PORTABLE RUMBLE STRIP ARRAY
-  DIRECTION OF TRAFFIC
-  WORK AREA
-  FLAGGER, EQUIPPED WITH STOP/SLOW PADDLE FASTENED ON SUPPORT STAFF

GENERAL NOTES

DETAILS OF TRAFFIC CONTROL DEVICES AND INSTALLATION NOT SHOWN ON THIS DRAWING SHALL CONFORM TO THE PERTINENT REQUIREMENTS OF THE STANDARD SPECIFICATIONS, THE SPECIAL PROVISIONS, AND THE MANUAL ON UNIFORM TRAFFIC CONTROL DEVICES.

ALL SIGNS ARE 48" X 48" UNLESS OTHERWISE NOTED.

"WO" SIGNS ARE THE SAME AS "W" SIGNS EXCEPT THE BACKGROUND IS ORANGE.

THE EXACT NUMBER, LOCATION AND SPACING OF ALL SIGNS, DEVICES, AND LOCATION OF ALL FLAGGERS SHALL BE ADJUSTED TO FIT FIELD CONDITIONS AS APPROVED BY THE ENGINEER.

THE FIRST ADVANCE WARNING SIGN SHOULD TYPICALLY BE LOCATED IN ADVANCE OF THE ANTICIPATED TRAFFIC BACKUP OR QUEUE.

WHEN A SIDE ROAD OR RAMP INTERSECTS THE FACILITY ON WHICH THE WORK IS BEING PERFORMED, ADDITIONAL TRAFFIC CONTROLS SHALL BE PROVIDED AS SPECIFIED IN THE PLANS AND/OR THE SPECIAL PROVISIONS OR AS APPROVED BY THE ENGINEER.

FLAGGING

FLAGGERS SHALL BE IN SIGHT OF EACH OTHER OR IN DIRECT COMMUNICATION AT ALL TIMES. THEY SHALL BE EQUIPPED WITH STOP/SLOW PADDLES FASTENED ON SUPPORT STAFFS. WHEN THE FLAGGING OPERATION IS NOT IN EFFECT REMOVE TEMPORARY PORTABLE RUMBLE STRIPS PRIOR TO COVERING OR REMOVING ALL ADVANCE SIGNING.

- ① FOR MOVING WORK OPERATIONS, POST ADDITIONAL W20-7A FLAGGER SIGNS AT APPROXIMATELY 3,500' INTERVALS IN THE MOVING WORK OPERATION OR AS APPROVED BY THE ENGINEER.
- ② SIGN NOT REQUIRED IF FLAGGING OPERATION OCCURS WITHIN A SIGNED ROAD WORK ZONE AREA.

WHEN THE DISTANCE BETWEEN FLAGGERS EXCEEDS 2 MILES, A PILOT CAR IS REQUIRED. WHEN CURVES REDUCE SIGHT DISTANCE BELOW 400', A PILOT CAR IS REQUIRED.

TEMPORARY PORTABLE RUMBLE STRIPS

UTILIZE TEMPORARY PORTABLE RUMBLE STRIPS ON ALL FLAGGING OPERATIONS.

- ③ EACH TEMPORARY PORTABLE RUMBLE STRIP ARRAY CONSISTS OF THREE RUMBLE STRIPS PLACED TRANSVERSE ACROSS THE LANE AT THE LOCATIONS SHOWN. WITHIN EACH ARRAY, SPACING BETWEEN RUMBLE STRIPS SHALL BE 15 FEET ON CENTER

ONLY USE TEMPORARY PORTABLE RUMBLE STRIPS FROM THE APPROVED PRODUCTS LIST.

INSTALL TEMPORARY RUMBLE STRIPS PER MANUFACTURER'S RECOMMENDATIONS.

PLACE ADVANCE SIGNING PRIOR TO INSTALLING TEMPORARY RUMBLE STRIPS.

DO NOT INSTALL TEMPORARY PORTABLE RUMBLE STRIPS ON GRAVEL, MILLED SURFACES, OR ASPHALT THAT HAS BEEN PAVED LESS THAN 12 HOURS.

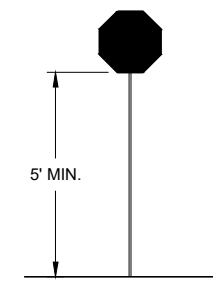

STOP/SLOW PADDLE ON SUPPORT STAFF

SIGN AND TEMPORARY RUMBLE STRIP ARRAY SPACING TABLE

SPEED LIMIT	SPACING "A"
25-30 MPH	200'
35-40 MPH	350'
45-55 MPH	500'



USE OF W03-4 SIGN IS OPTIONAL. WHEN USED, THIS SIGN SHALL BE LOCATED BETWEEN THE W20-7A AND W20-4A SIGNS, USING SPACING "A".

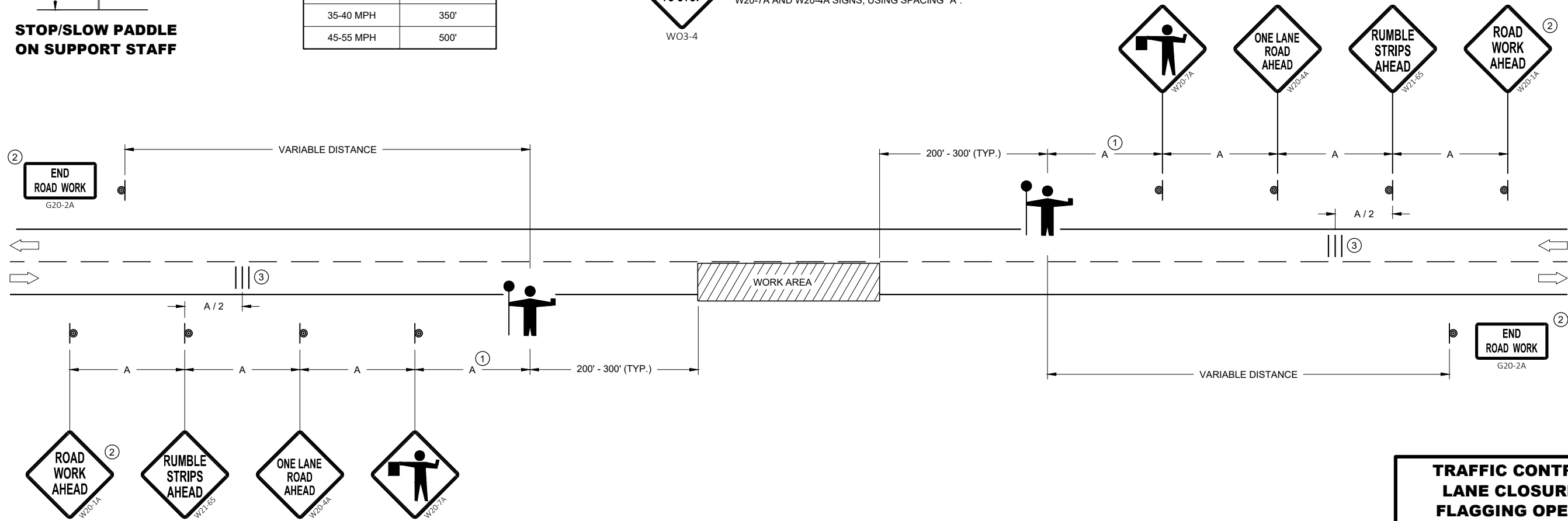

TRAFFIC CONTROL FOR LANE CLOSURE WITH FLAGGING OPERATION

STATE OF WISCONSIN
DEPARTMENT OF TRANSPORTATION

APPROVED
DATE: May 2022 /S/ Andrew Heidtke
WORK ZONE ENGINEER

FHWA

GENERAL NOTES

- ① DIAGONALS ARE OPTIONAL WHEN PAINTED ISLAND IS LESS THAN 6 FEET AT THE WIDEST POINT. OMIT DIAGONALS IF WIDTH IS LESS THAN 4 FEET.

➔ DIRECTION OF TRAVEL

* WHEN THE PAINTED MEDIAN LENGTH IS LESS THAN 50 FEET THE SPACING IS 10'.

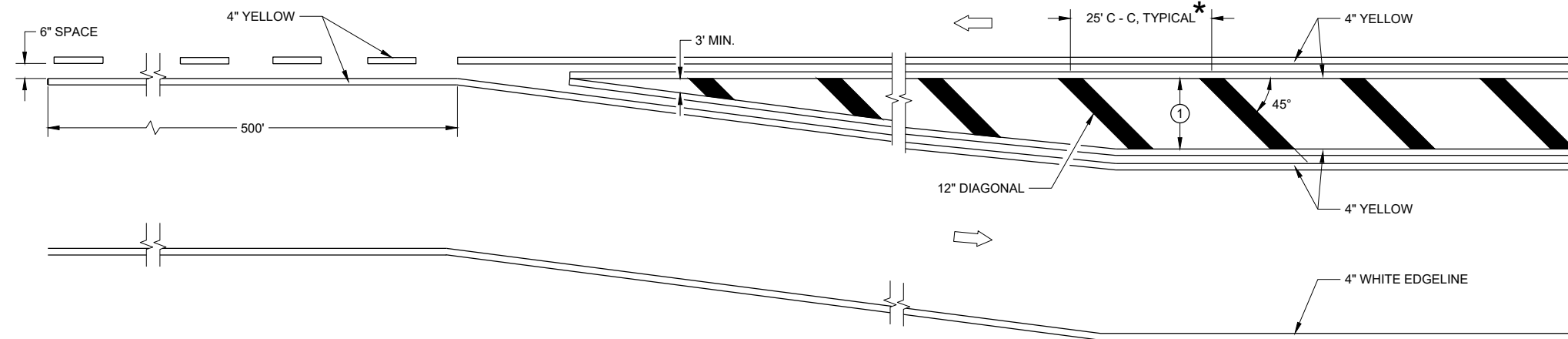

MEDIAN ISLAND DETAIL

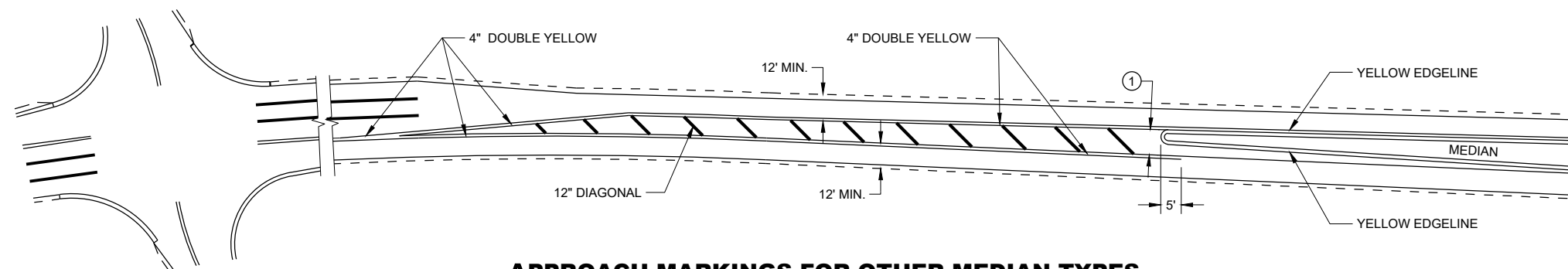

APPROACH MARKINGS FOR OTHER MEDIAN TYPES

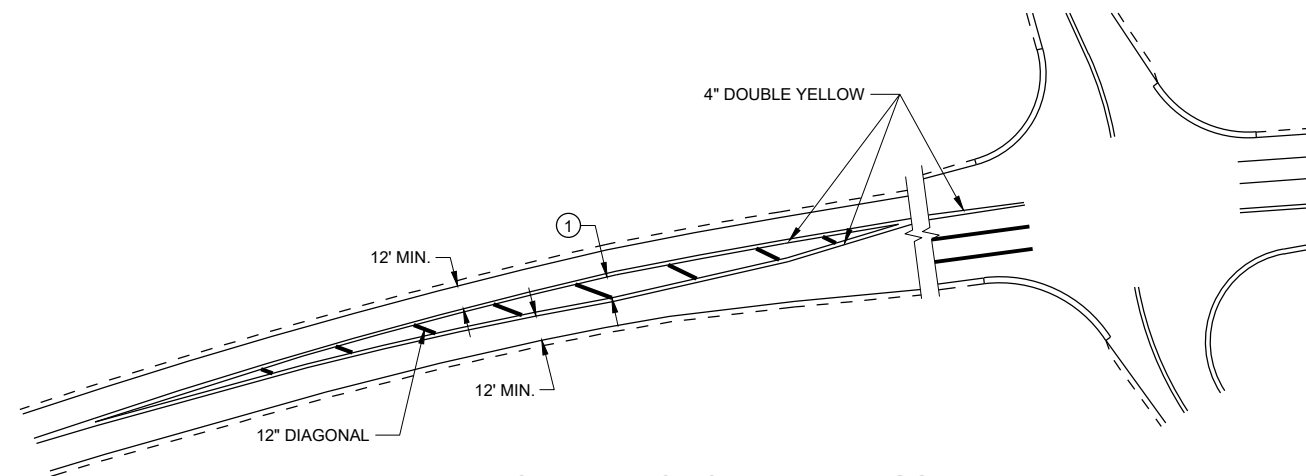

NON-APPROACH MARKINGS

6

6

SDD 15C18 - 06a

SDD 15C18 - 06a





**MEDIAN ISLAND
PAVEMENT MARKINGS**

STATE OF WISCONSIN
DEPARTMENT OF TRANSPORTATION

APPROVED
May 2022 DATE /S/ Jeannie Silver
STATE SIGNING AND MARKING
ENGINEER

FHWA

LEGEND

- V1 LEAD VEHICLE
- V2 MARKING VEHICLE
- V3 SHADOW VEHICLE
-  TRUCK MOUNTED ATTENUATOR (TMA)
-  SIGN ON TEMPORARY SUPPORT
-  DIRECTION OF TRAFFIC
-  FLASHING ARROW PANEL (CAUTION)

GENERAL NOTES

ALL VEHICLES SHALL BE EQUIPPED WITH TWO 360 DEGREE HIGH INTENSITY YELLOW FLASHING LIGHTS OR STROBE LIGHTS AND OPERATED WITH HEADLIGHTS TURNED ON.

ALL VEHICLES SHALL BE EQUIPPED WITH REAR FACING TYPE B OR C FLASHING ARROW PANEL OPERATING IN CAUTION MODE. SIGNS PLACED ON VEHICLES MUST NOT OBSCURE THE ARROW PANEL.

ALL SIGNS ARE 48" X 48" UNLESS OTHERWISE SPECIFIED.

DISTANCE BETWEEN VEHICLES MAY VARY ACCORDING TO TERRAIN, SIGHT DISTANCE, PAINT DRYING TIME, AND OTHER FACTORS. WHENEVER ADEQUATE STOPPING SIGHT DISTANCE EXISTS TO THE REAR, SHADOW VEHICLES SHOULD MAINTAIN THE MINIMUM DISTANCE FROM THE WORK VEHICLE AND PROCEED AT THE SAME SPEED AS THE WORK VEHICLE. SHADOW VEHICLES SHOULD SLOW DOWN IN ADVANCE OF VERTICAL AND HORIZONTAL CURVES THAT RESTRICT SIGHT DISTANCE.

THE WORK AND SHADOW VEHICLES SHOULD PULL OVER PERIODICALLY TO ALLOW TRAFFIC TO PASS.

WHEN NO WORK ACTIVITY IS TAKING PLACE, REMOVE OR LAY STATIONARY SIGNS AND SUPPORTS FLAT ON THE GRADE WITH UPRIGHTS ORIENTED PARALLEL TO AND DOWNSTREAM FROM TRAFFIC.

CONES SHOULD BE USED BETWEEN THE MARKING AND SHADOW VEHICLE AT 100 FOOT SPACING. CONES MAY BE OMITTED ON PAINTED LINE IF APPROVED BY THE ENGINEER. CONSIDER PAVEMENT MARKING DRY OR CURE TIMES AND TRAFFIC VOLUME.

CONES SHALL BE A MINIMUM OF 28" FOR WET PAVEMENT MARKING.

- ① SIGNS SHALL BE REPEATED APPROXIMATELY EVERY THREE MILES.
- ② IF CONSTRUCTION WORK ZONE SIGNS ARE IN PLACE, W20-1A OR W21-63 ARE NOT REQUIRED.
- ③ V1 AND V2 CAN BE SWITCHED SO THAT THE MARKER IS THE LEAD VEHICLE.

6

6

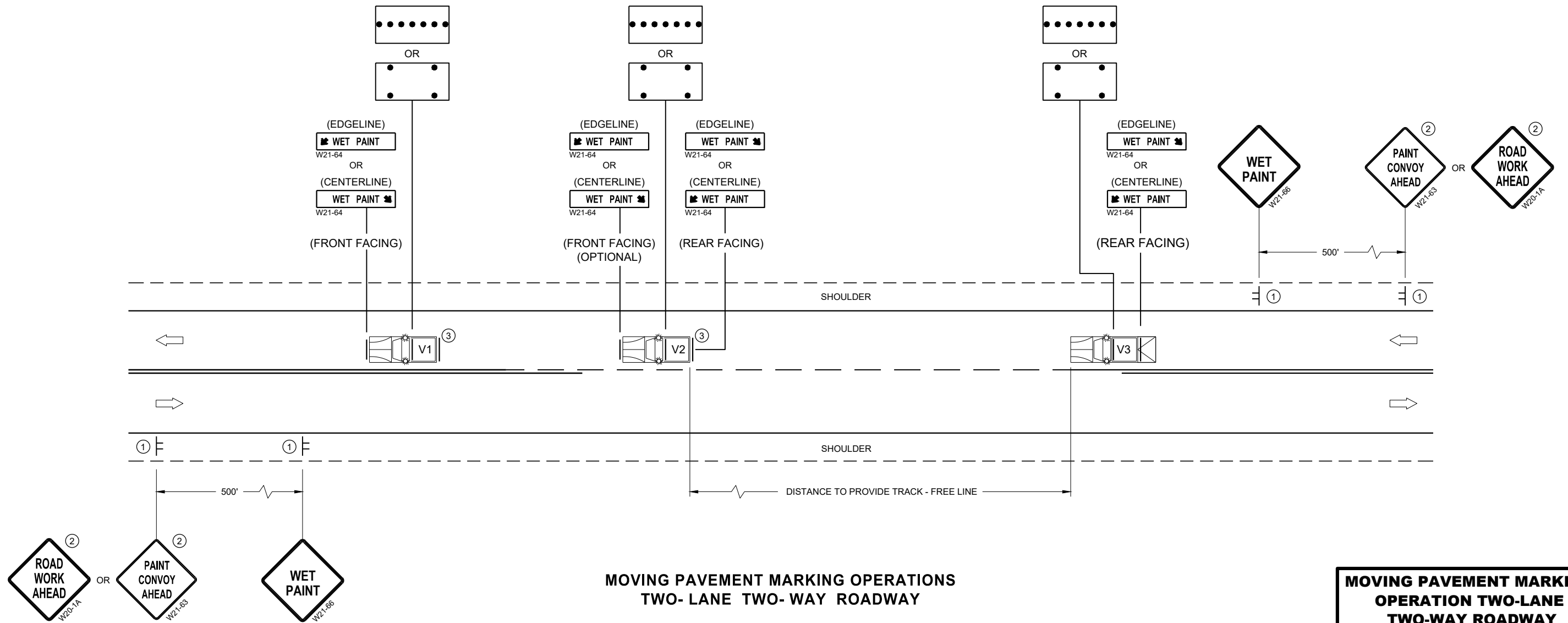

SDD 15C19 - 07a

SDD 15C19 - 07a

**MOVING PAVEMENT MARKING OPERATIONS
TWO-LANE TWO-WAY ROADWAY**

MOVING PAVEMENT MARKING OPERATION TWO-LANE TWO-WAY ROADWAY	
STATE OF WISCONSIN DEPARTMENT OF TRANSPORTATION	
APPROVED DATE	/S/ Andrew Heidtke WORK ZONE ENGINEER
FHWA	

GENERAL NOTES

OMIT EDGE LINES THROUGH INTERSECTIONS. CONTINUE EDGE LINES THROUGH DRIVEWAYS.

- ① WHEN DISTANCE "A" IS LESS THAN 250 FEET, OMIT LANE LINE.
- ② WHEN DISTANCE "B" IS LESS THAN 100 FEET, OMIT CHANNELIZING LANE LINE.
- ③ BARRIER LINE ENDS AT SIDE ROAD PAVEMENT / SURFACE EDGE EXTENSION.
- ④ BARRIER LINE STARTS 500 FEET PRIOR TO THE BYPASS TAPER.
- ⑤ WHEN DISTANCE "C" IS LESS THAN 4 FEET, OMIT DOTTED EXTENSION.
- ⑥ WHEN DISTANCE "D" IS LESS THAN 50 FEET, OMIT DOTTED EXTENSION.

LEGEND

➡ DIRECTION OF TRAVEL

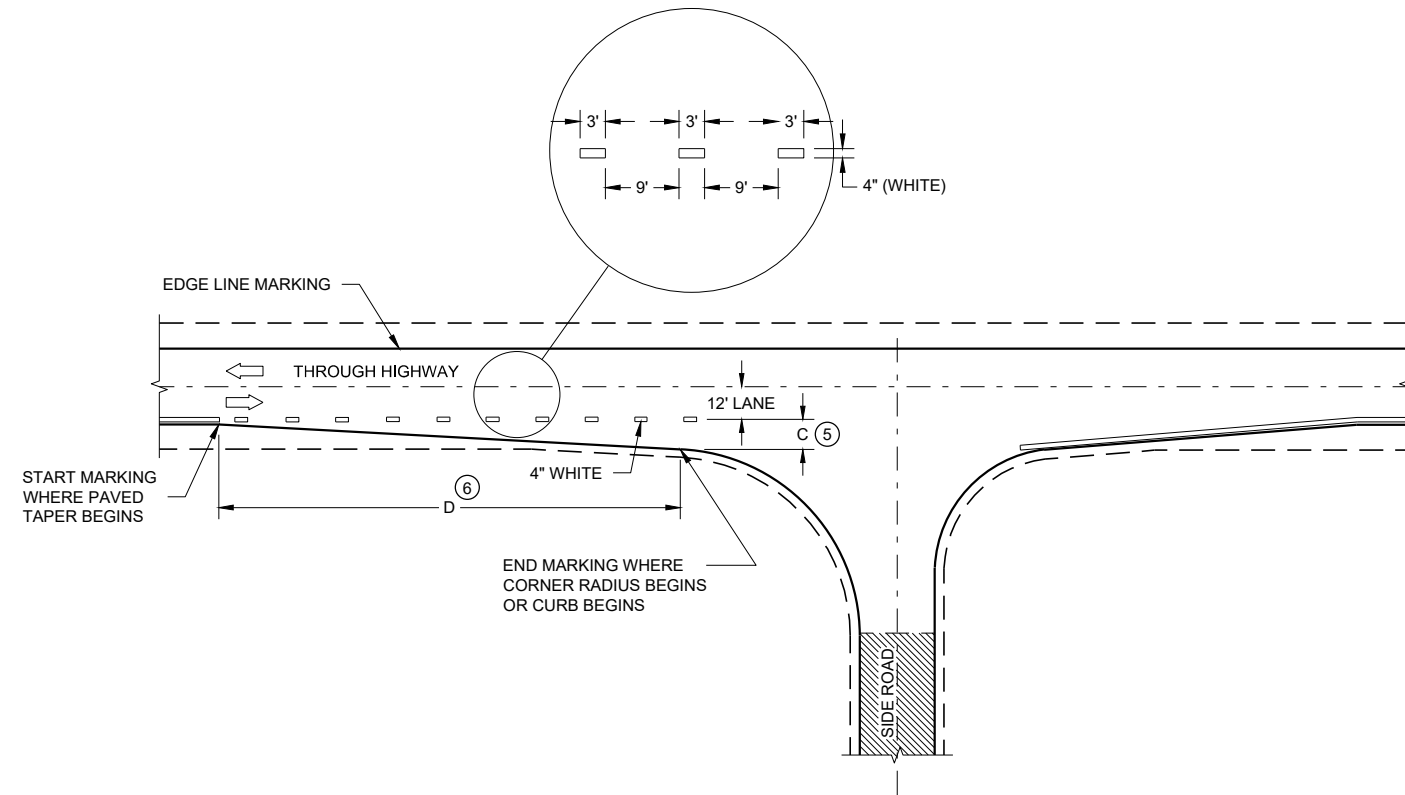

MINOR INTERSECTION

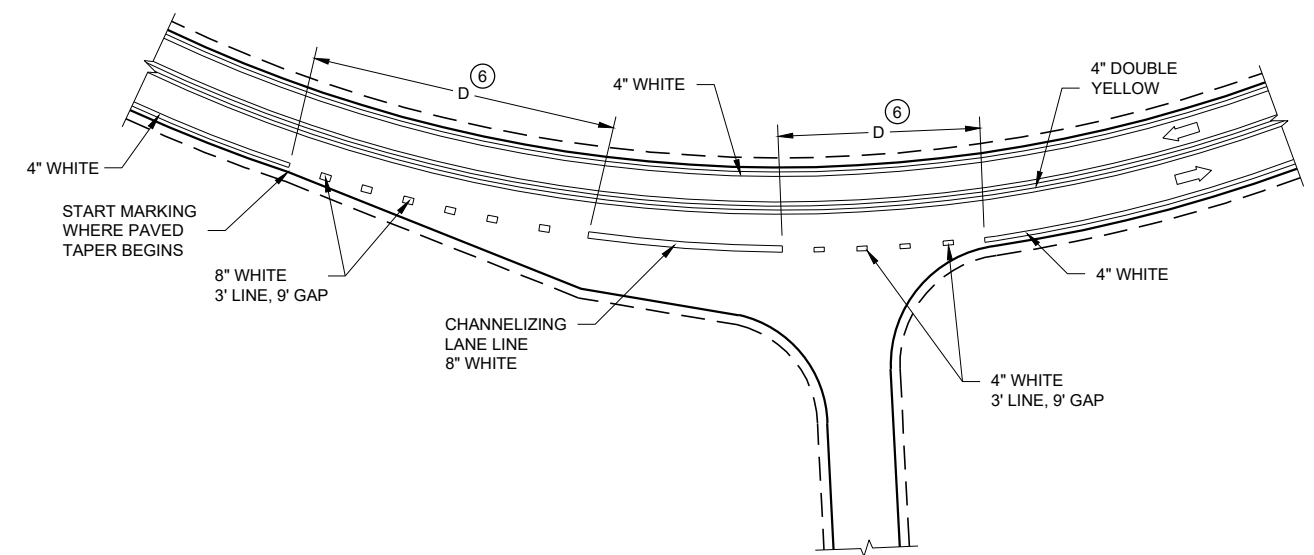

INTERSECTION ON OUTSIDE OF CURVE

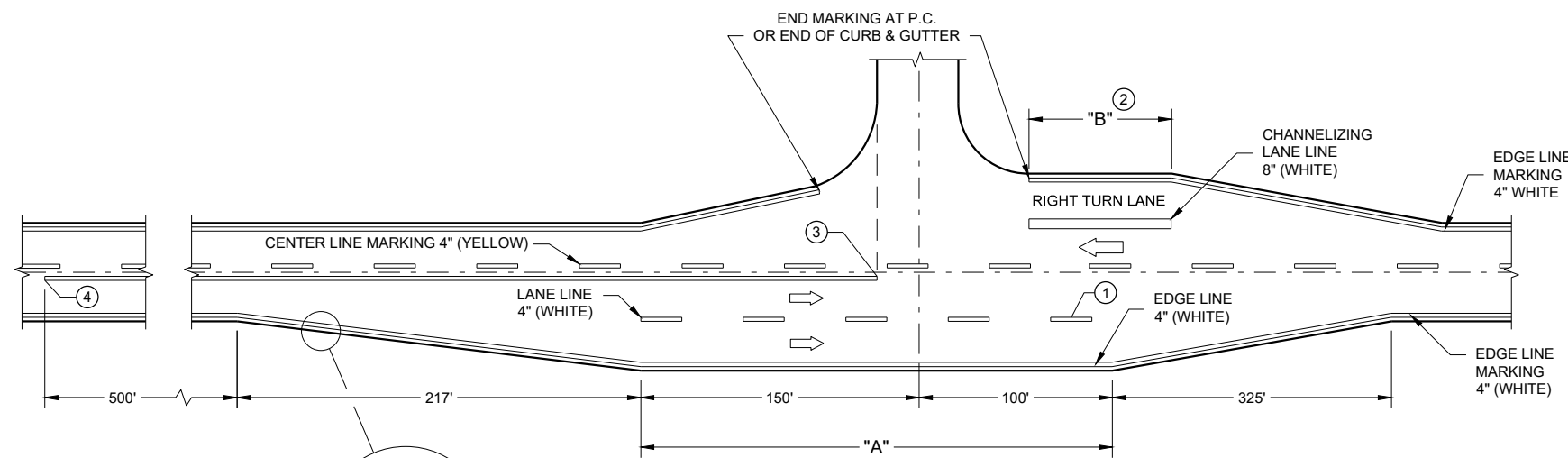

**MAJOR INTERSECTIONS
(INTERSECTION WITH FULL RIGHT TURN LANE OR BYPASS LANE)**

BYPASS LANE PAVED SHOULDER WIDTH (AS SHOWN ELSEWHERE IN PLANS) - PLUS 2 INCHES

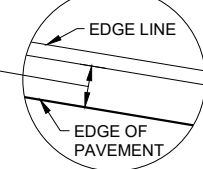

**PAVEMENT MARKING
(INTERSECTIONS)**

STATE OF WISCONSIN
DEPARTMENT OF TRANSPORTATION

GENERAL NOTES

DRAWING NOT TO SCALE. ALL SIGNS AND POSTS ON THIS SHEET SHALL BE PAID FOR WITH 'TRAFFIC CONTROL SIGNS' BID ITEM. ALL SIDE ROADS WHICH ARE UNDER CONSTRUCTION OF CURB AND GUTTER AND/OR GRADING SHALL BE ADEQUATELY SIGNED.

ALL SIGNS AND DEVICES SHALL BE IN CONFORMANCE WITH THE WISCONSIN MANUAL OF UNIFORM TRAFFIC CONTROL DEVICES (WMUTCD). SIGN LAYOUTS SHALL BE IN ACCORDANCE WITH THE WISDOT STANDARD SIGN PLATES.

"WO" SIGNS ARE THE SAME AS "W" SIGNS EXCEPT THAT THE BACKGROUND IS ORANGE.

ALL SIGNS ARE 48" X 48" UNLESS OTHERWISE NOTED.



THE EXACT NUMBER, LOCATION AND SPACING OF ALL SIGNS AND DEVICES SHALL BE ADJUSTED TO FIT FIELD CONDITIONS AS DIRECTED BY THE ENGINEER.

ALL SIGNS INAPPROPRIATE TO THE STATUS OF THE CONTROL ZONE, INCLUDING PRE-EXISTING SIGNS IN THE VICINITY, SHALL BE COVERED OR REMOVED AS DIRECTED BY THE ENGINEER.

SEE 15C34 FOR ADDITIONAL TRAFFIC CONTROL SIGNING WHEN CENTERLINE PAVEMENT MAKINGS ARE MISSING. 'DO NOT PASS' SIGNS MUST BE INSTALLED ON THE SAME DAY AS MILLING OPERATIONS.

- ① PLACE SIGNS 350' IN ADVANCE OF MILLED SURFACES AND AT 1 MILE INTERVALS, OR AS DIRECTED BY THE ENGINEER.
- ② PLACE SIGN 200' MIN. FROM INTERSECTION AND 200' MIN. AFTER ADVANCE WARNING SIGN SHOWN IN SDD 15C04.

LEGEND

-  SIGN ON TEMPORARY SUPPORT
-  DIRECTION OF TRAFFIC

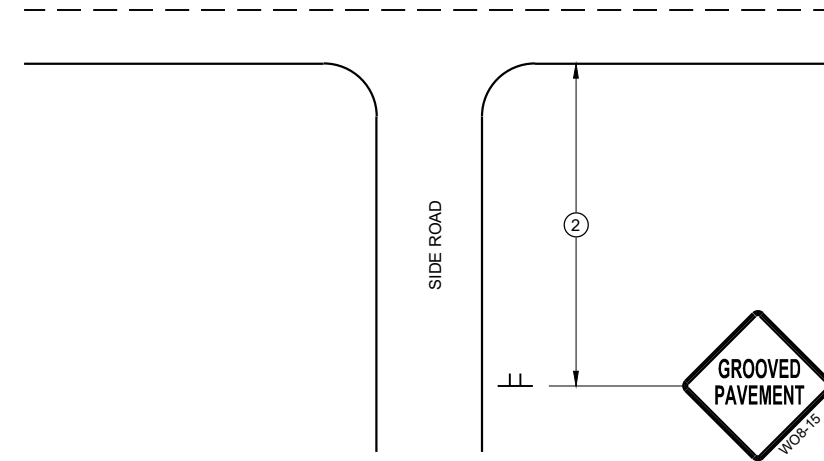

TYPICAL SIDE ROAD APPROACH SIGN DETAIL

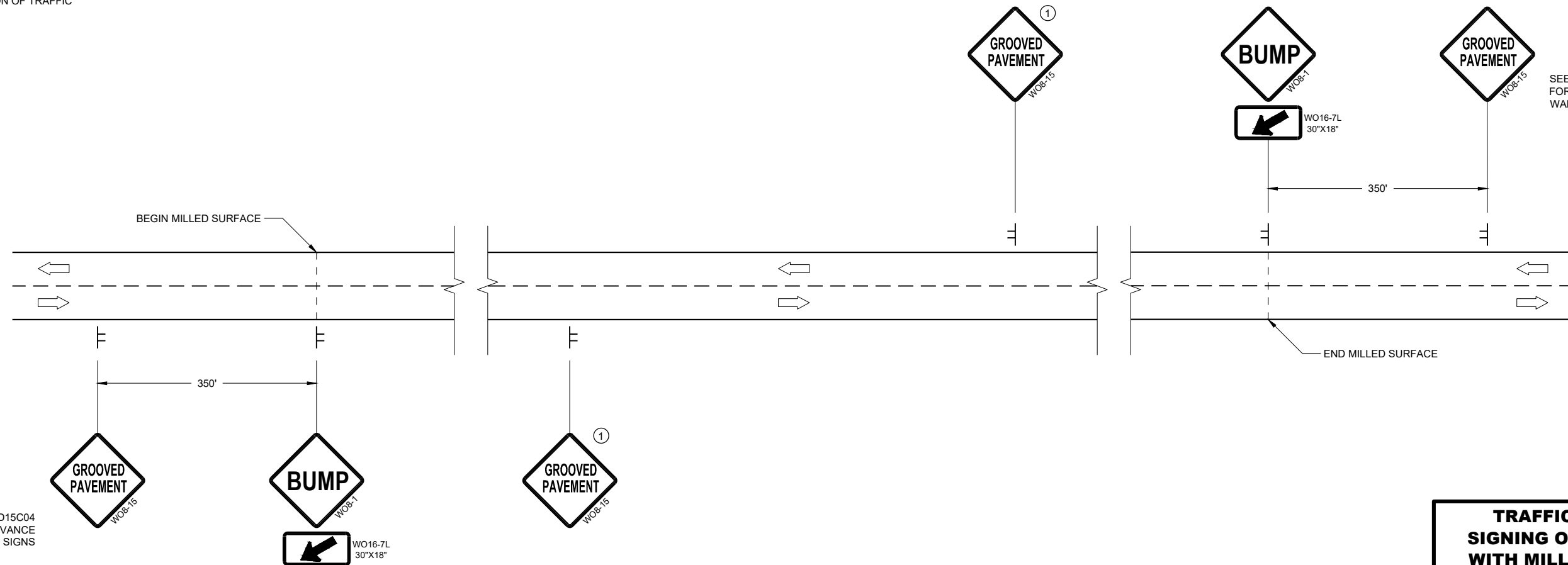

DETAIL FOR SIGNING ON MILLED SURFACES

TRAFFIC CONTROL, SIGNING ON ROADWAYS WITH MILLED SURFACES	
STATE OF WISCONSIN DEPARTMENT OF TRANSPORTATION	
APPROVED February 2020 DATE	/s/ Andrew Heidtke WORK ZONE ENGINEER
FHWA	







6

6

SDD 15D44 - 02

SDD 15D44 - 02

LEGEND

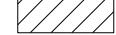
-  TYPE III BARRICADE WITH ATTACHED SIGN
-  SIGN ON PERMANENT SUPPORT
-  TRAFFIC CONTROL DRUM
-  TRAFFIC CONTROL DRUM WITH TYPE "C" STEADY BURN LIGHT
-  TYPE "A" WARNING LIGHT (FLASHING)
-  DIRECTION OF TRAFFIC
-  WORK AREA

POSTED SPEED LIMIT PRIOR TO WORK STARTING (MPH)	ADVANCE WARNING SIGN SPACING (A) FEET	SHIFTING TAPER $L/2$					
		W, LATERAL OFFSET (FT)					
		3	4	5	6	7	8
25	200	10	14	17	21	24	28
30	200	15	20	25	30	35	40
35	350	20	27	34	40	47	54
40	350	26	35	44	53	62	70
45	500	45	59	74	89	104	119
50	500	50	66	83	99	116	132
55	500	54	73	91	109	127	145

GENERAL NOTES

THE EXACT NUMBER, LOCATION, AND SPACING OF ALL SIGNS AND DEVICES SHALL BE ADJUSTED TO FIT FIELD CONDITIONS AS APPROVED BY THE ENGINEER.

ALL SIGNS ARE 48"x48" UNLESS OTHERWISE NOTED. IF NECESSARY DUE TO SPACE CONSTRAINTS IN URBAN AREAS, 36"x36" SIGNS MAY BE USED IF APPROVED BY THE REGIONAL TRAFFIC UNIT.

"WO" IS THE SAME AS "W" EXCEPT THE BACKGROUND IS ORANGE.

ANY SIGNS TEMPORARY OR EXISTING, WHICH CONFLICT WITH TRAFFIC CONTROL "IN USE" SHALL BE REMOVED OR COVERED AS NEEDED AND AS APPROVED BY THE ENGINEER.

CHANNELIZING DEVICES PLACED ADJACENT TO WORK AREA SHALL BE PULLED BACK FROM THE TRAVEL LANE WHEN WORK IS NOT IN PROGRESS.

SIGNS THAT WILL BE IN PLACE LESS THAN 7 CONTINUOUS DAYS AND NIGHTS MAY BE MOUNTED ON PORTABLE SUPPORTS.

W20-1 AND G20-2A SIGNS ARE NOT REQUIRED IF THE WORK AREA IS WITHIN A LARGER WORK ZONE WHERE THESE SIGNS ARE ALREADY PRESENT. G20-2A SIGNS MAY ALSO BE OMITTED IF DURATION WORK IS LESS THAN SEVEN CONTINUOUS DAYS AND NIGHTS.

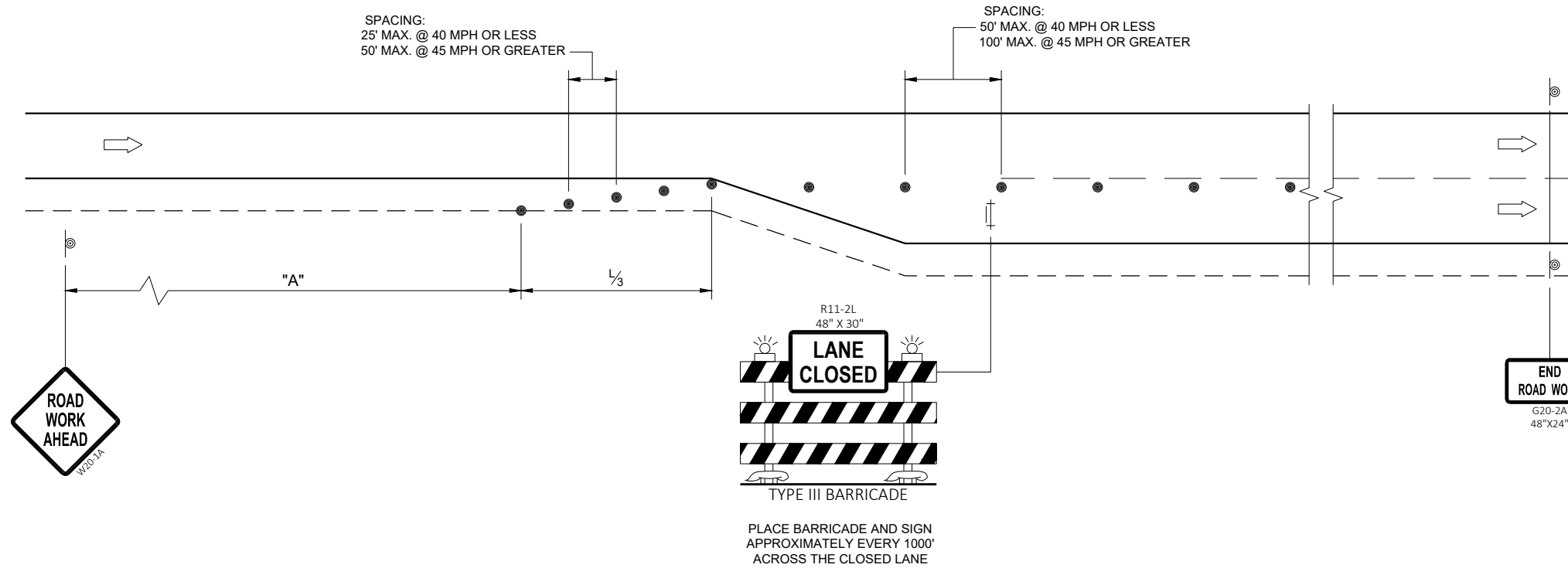

6

6

SDD 15D50 - 02a

SDD 15D50 - 02a

TRAFFIC CONTROL ADDED LANE CLOSURE WITHOUT LANE SHIFT	
STATE OF WISCONSIN DEPARTMENT OF TRANSPORTATION	
APPROVED February 2022 DATE	/S/ Andrew Heidtke WORK ZONE ENGINEER
FHWA	

URBAN AREA

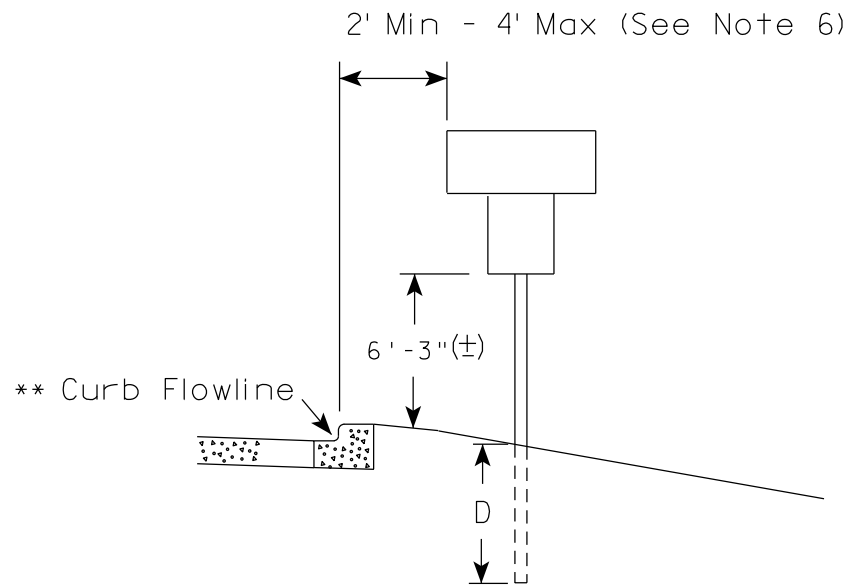
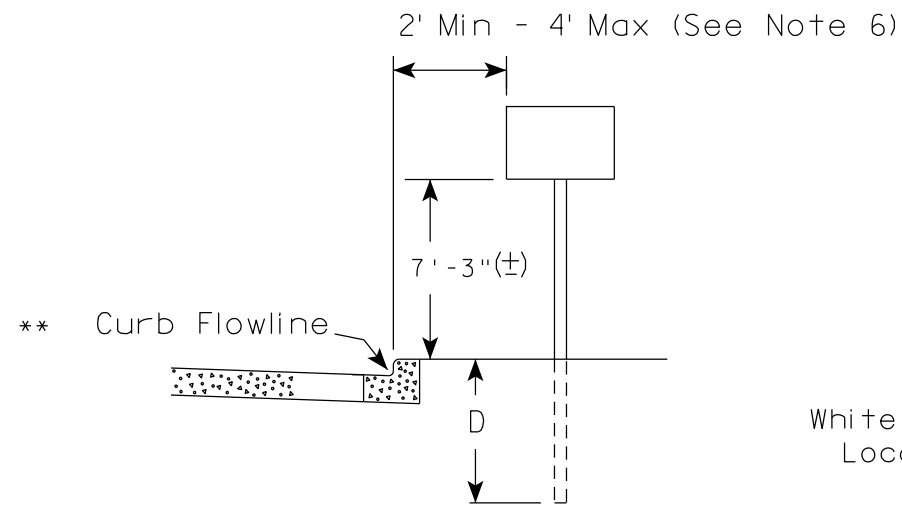

RURAL AREA (See Note 2)

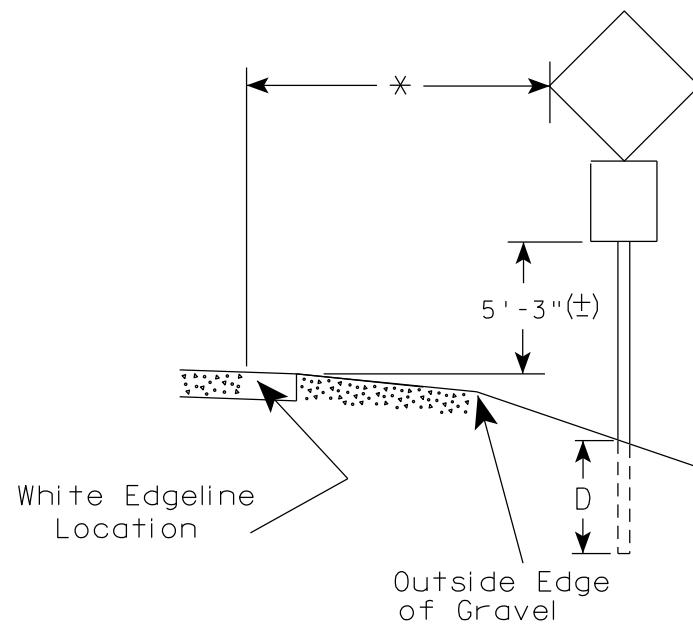
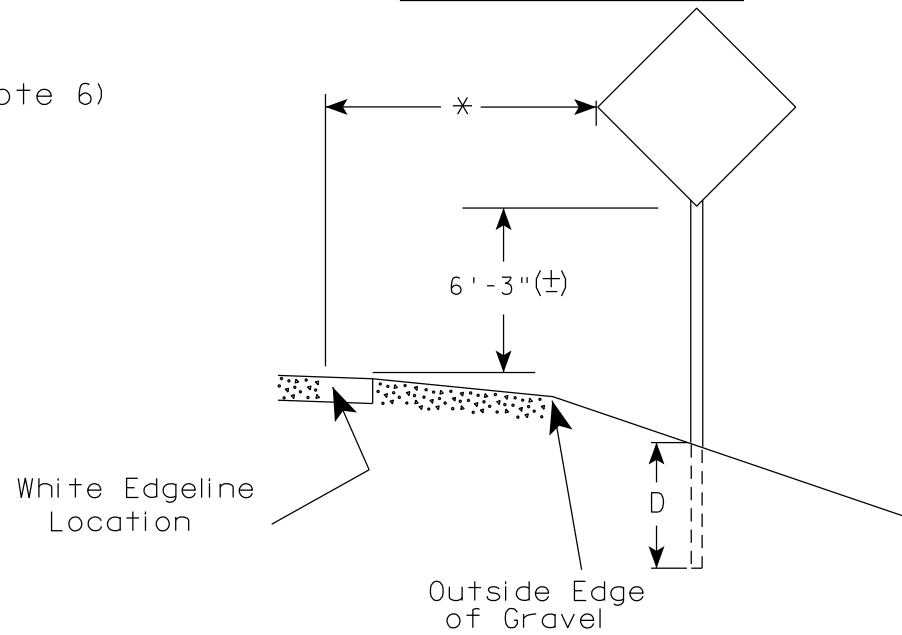

GENERAL NOTES

1. Signs wider than 4 feet or 20 sq.ft or larger, shall be mounted on multiple posts. Refer to plate A4-4.
2. If signs are mounted on or behind barrier wall, see A4-10 sign plate.
The Double Arrow sign (W12-1D) shall be mounted at a height of 2'-3" (±). The Chevron sign (W1-8), Roundabout Chevron panel (R6-4B), Enhanced Reference Markers, Clearance Markers (W5-52), Mile Markers (D10 series), In Road Object Markers (W5-54) & End of Road Markers (W5-56) shall be mounted at a height of 4'-3" (±).
3. For expressways and freeways, mounting height is 7'- 3" (±) or 6'-3" (±) depending upon existence of a sub-sign.
4. Minimum mounting height for signs mounted on traffic signal poles is 5'- 3" (±).
5. Offset distance shall be consistent with existing signs or consistent throughout length of project.
6. The (±) tolerance for mounting height is 3 inches.
7. Folding signs shall be mounted at a height of 5'-3" (±) or as directed by the Engineer.

POST EMBEDMENT DEPTH

Area of Sign Installation (Sq. Ft.)	D (Min)
20 or Less	4'
Greater than 20	5'

* * The existence of curb and gutter does not in itself mandate the vertical clearance illustrated. That height is typically measured where there is sidewalk adjacent to the roadway or parking is permitted. In the absence of sidewalk vertical clearance is measured from the top of the curb. Offset of signs is measured from the flow line.

* 6 feet from edge of a paved shoulder or 12 feet from the edge of pavement (edge line location) or 2 feet from outside edge of gravel, whichever is greater unless directed by project engineer.

TYPICAL INSTALLATION OF PERMANENT TYPE II SIGNS ON SINGLE POSTS

WISCONSIN DEPT OF TRANSPORTATION

APPROVED *Matthew R. Rauch*
for State Traffic Engineer

DATE 5/13/2020 PLATE NO. A4-3.22

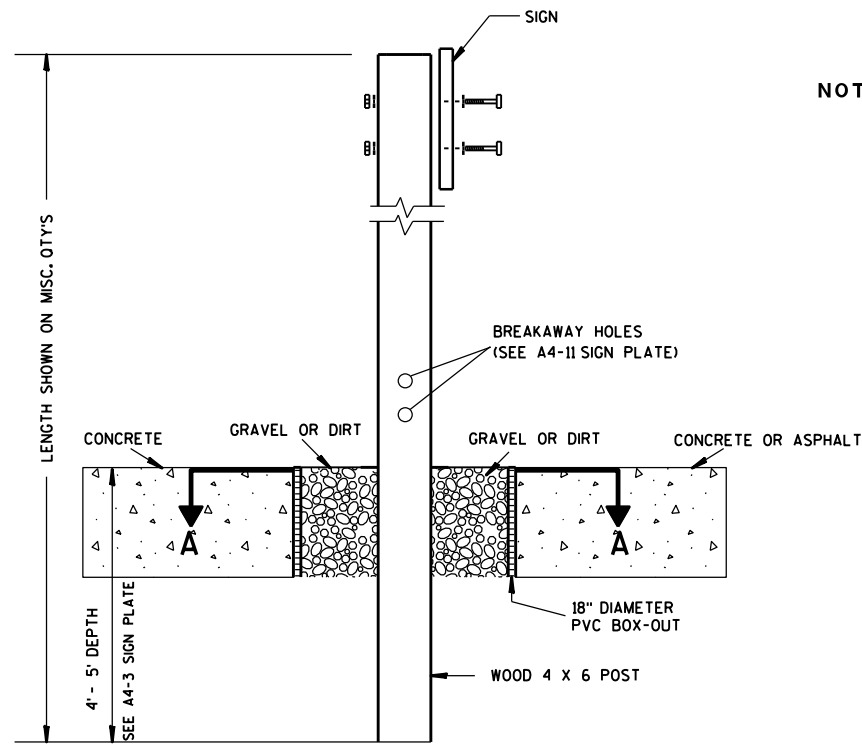

ELEVATION VIEW

DETAIL OF WOOD 4 X 6 SIGN POST IN BOX-OUT

- NOTES:**
1. ALL MATERIAL TO BE APPROVED BY ENGINEER PRIOR TO INSTALLATION
 2. SEE SIGN PLATE A4-8 FOR SIGN HARDWARE REQUIREMENTS
 3. 18 INCH X 18 INCH SQUARE BOX-OUTS MAY BE USED FOR INSTALLATIONS IN EXISTING CONCRETE OR ASPHALT LOCATIONS.

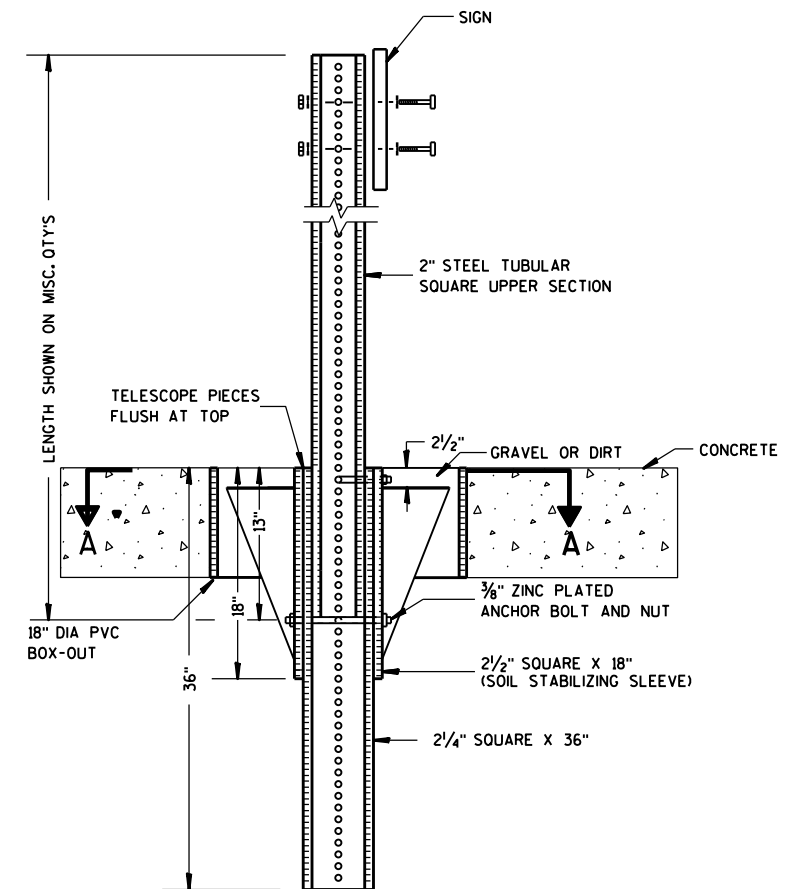

ELEVATION VIEW

DETAIL OF STEEL 2 X 2 SIGN POST IN BOX-OUT

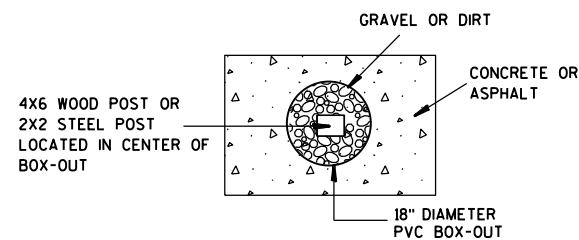

PLAN VIEW

FOR NEW CONCRETE/ASPHALT INSTALLATIONS

**SIGN POST
BOX-OUTS
A4-3B**

WISCONSIN DEPT OF TRANSPORTATION

APPROVED *Matthew R. Rauch*
for State Traffic Engineer

DATE 1/27/14 PLATE NO. A4-3B.1

7

7

GENERAL NOTES

1. For 3 or 4 post installations, individual post spacing shall be greater than 3'-6".
2. See tables below for required number of posts.
3. For expressways and freeways, mounting height is 7'-3" (±) or 6'-3" (±) depending upon existence of sub-sign.
4. The (±) tolerance for mounting height is 3 inches.
5. J-Assemblies are considered to be one sign for mounting height.
6. Offset distance shall be consistent with existing signs or consistent throughout length of project.
7. Folding signs shall be mounted at a height of 5'-3" (±) or as directed by the engineer.
8. The Double Arrow sign (W12-1) shall be mounted at a height of 2'-3" (±). The Chevron sign (W1-8), Roundabout Chevron panel (R6-4B), Clearance Markers (W5-52), Mile Markers (D10 series), In Road Object Markers (W5-54) & End of Road Markers (W5-56) shall be mounted at a height of 4'-3" (±).

URBAN AREA

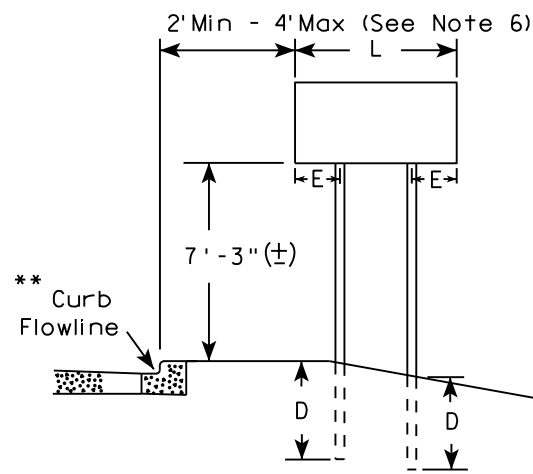

RURAL AREA (See Note 3)

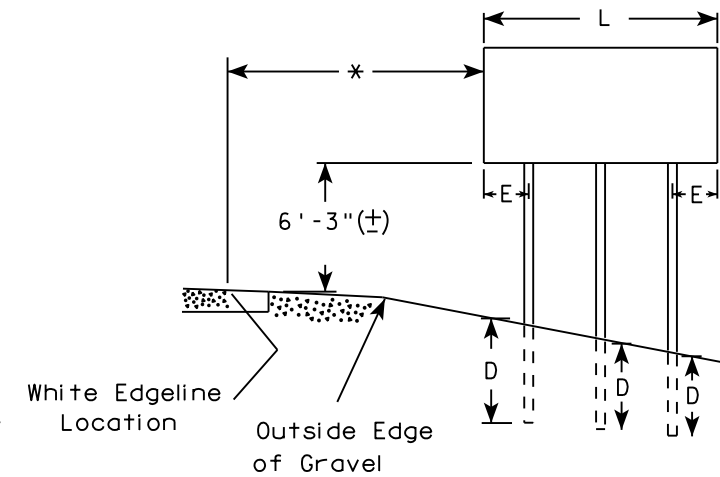
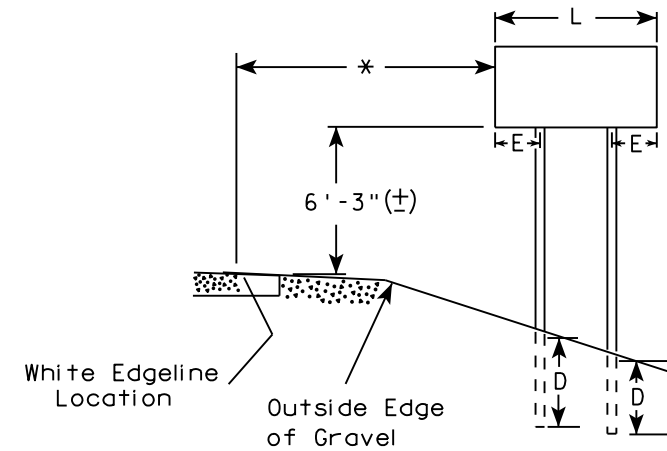

2' Min - 4' Max (See Note 6)

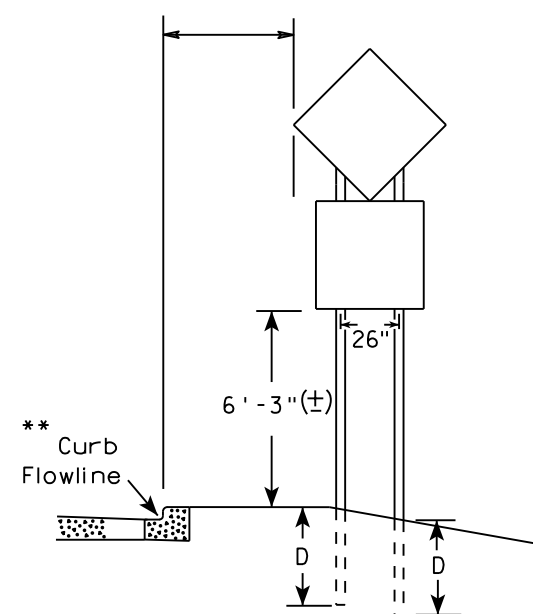

48" DIAMOND WARNING SIGN

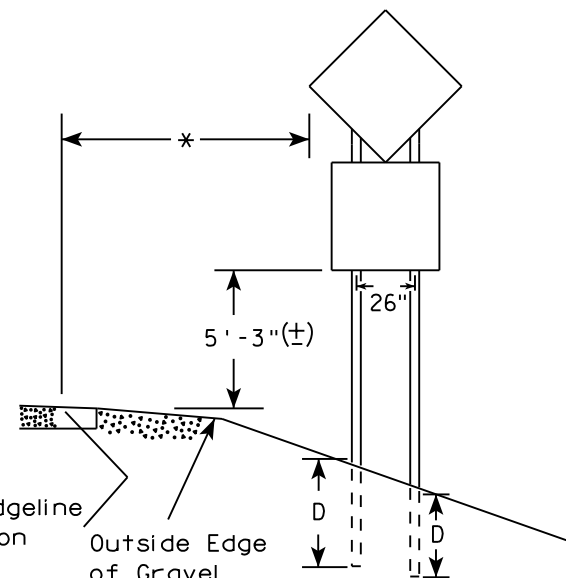

48" DIAMOND WARNING SIGN

* 6 feet from edge of a paved shoulder or 12 feet from the edge of pavement (edge line location) or 2 feet from outside edge of gravel, whichever is greater unless directed by project engineer.

** The existence of curb and gutter does not in itself mandate the vertical clearance illustrated. That height is typically measured where there is sidewalk adjacent to the roadway or parking is permitted. In the absence of sidewalk vertical clearance is measured from the top of the curb. Offset of signs is measured from the flow line.

*** See A4-3 sign plate for signs 4' or less in width and less than 20 S.F. in area.

SIGN SHAPE OTHER THAN DIAMOND (TWO POSTS REQUIRED)	
L	E
Greater than 48" Less than 60"	12"
60" to 108"	L/5

SIGN SHAPE OTHER THAN DIAMOND (THREE POSTS REQUIRED)	
L	E
Greater than 108" to 144"	12"

POST EMBEDMENT DEPTH

Area of Sign Installation (Sq. Ft.)	D (Min)
20 or Less	4'
Greater than 20	5'

TYPICAL INSTALLATION OF TYPE II SIGNS ON MULTIPLE POSTS

WISCONSIN DEPT OF TRANSPORTATION
 APPROVED *Matthew R. Rauch*
 For State Traffic Engineer
 DATE 8/21/17 PLATE NO. A4-4.15

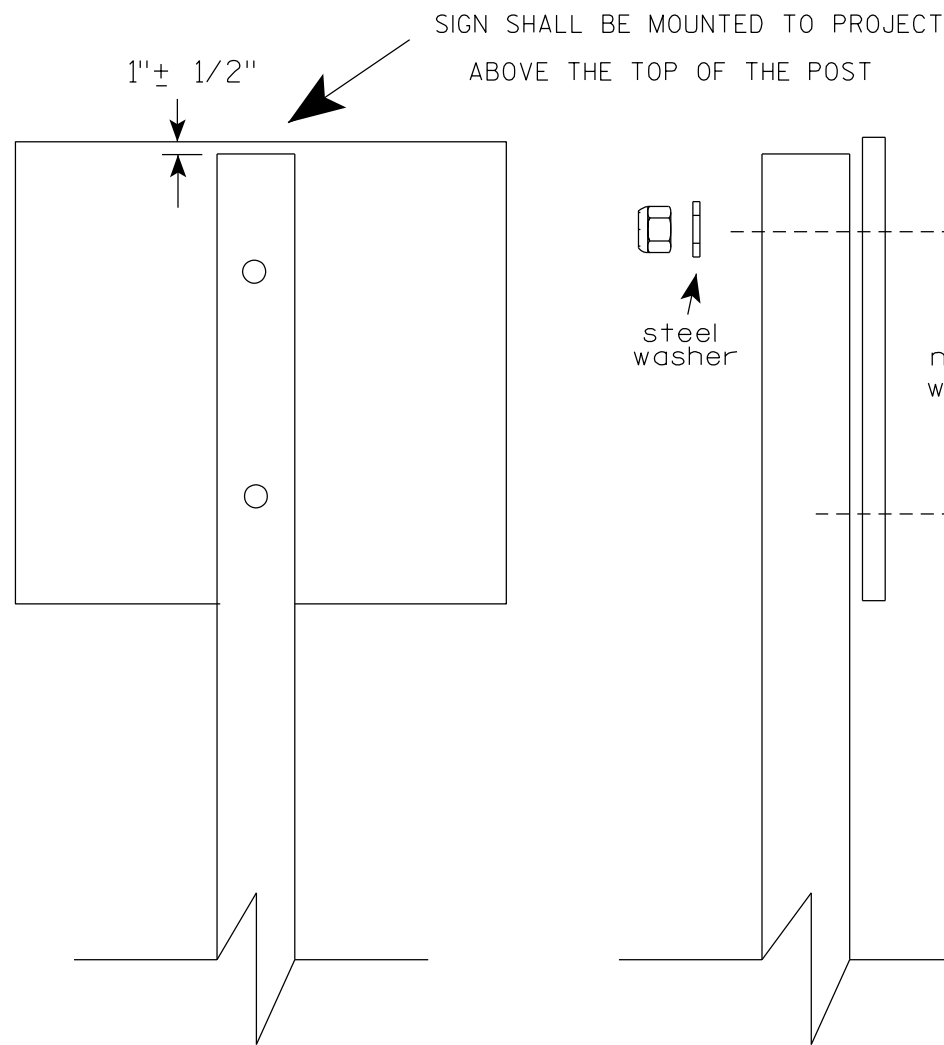

Nuts, bolts and lags used for mounting signs shall have hexagonal heads and shall be either :

- Hot dip galvanized in accordance with ASTM Designation: A 153, Class D, or SC 3
- Electro-galvanized in accordance with ASTM Designation : B 633, TYPE III, SC 3.

Threads on bolts and nuts shall be manufactured with sufficient allowance for the cadmium plate or galvanized coating to permit the nuts to run freely on the bolts.

- STRINGER BOLTING TO ALUMINUM SIGNS (SEE SIGN PLATE A4-18)
- MACHINE BOLTS - $\frac{5}{16}$ " X 1-3/4" Length w/ lock nuts
- WOOD POSTS (4" x 6")
- LAG SCREWS - $\frac{3}{8}$ " X 3" (NO STRINGERS ON BACK OF SIGN)
 - $\frac{3}{8}$ " X 4" (STRINGERS ON BACK OF SIGN)
- SQUARE STEEL POSTS (2" x 2")
- MACHINE BOLTS - $\frac{3}{8}$ " X 3-1/4" Length w/ nuts (NO STRINGER ON BACK OF SIGN)
 - $\frac{3}{8}$ " X 5" Length w/ nuts (STRINGERS ON BACK OF SIGN)
- RIVETS - $\frac{9}{32}$ " (6605-9-6) BULB-TITE, TRI-FOLD, ALUMINUM BODY/MANDREL
- O.D. FLANGE .720-.765 INCH, GRIP RANGE .042-.375 INCH
- WASHERS (ALL POSTS) -
- 1-1/4" O.D. X $\frac{3}{8}$ " I.D. X $\frac{1}{16}$ " STEEL
 - 1-1/4" O.D. X $\frac{3}{8}$ " I.D. X .080 NYLON

* Two different fastening systems are shown for illustration purposes. On any individual sign, either one or the other system shall be used. Actual number of fasteners per sign varies with the sign area, but normally there are two. For a single post installation, all signs greater than 9 sq. ft. require the use of 3 fasteners.

ATTACHMENT OF SIGNS TO POSTS	
WISCONSIN DEPT OF TRANSPORTATION	
APPROVED	<i>Matthew R Rauch</i> For State Traffic Engineer
DATE 4/1/2020	PLATE NO. A4-8.9

**TELESCOPIC TUBING ANCHORS
TWO PIECE SYSTEM**

**2 1/4" SQUARE
12 GAUGE
PERFORATED
GALVANIZED FINISH**

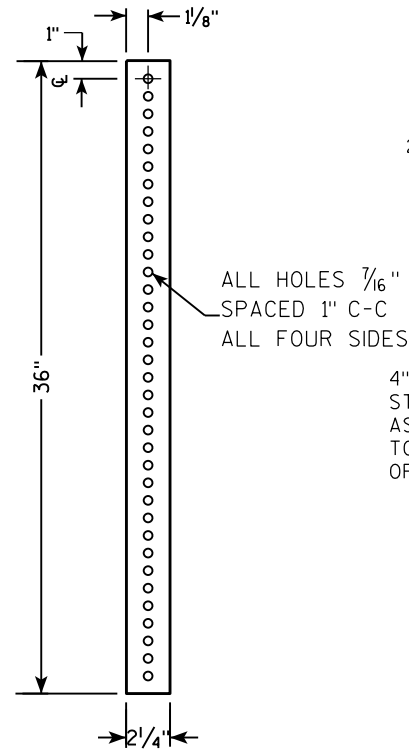

**2 1/2" SQUARE
12 GAUGE
OMNI-DIRECTIONAL
PERFORATED
SOIL STABILIZING SLEEVE
GALVANIZED FINISH**

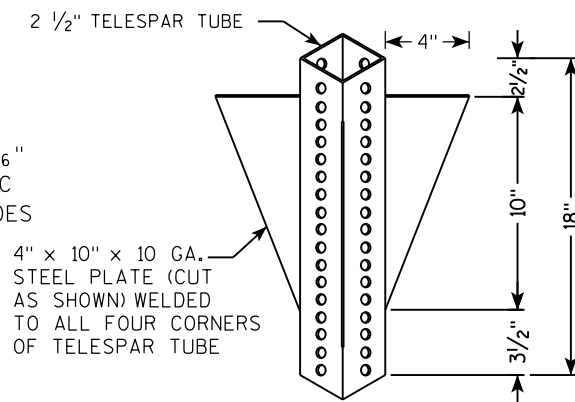

**DETAIL OF TUBULAR STEEL SIGN POST
(IN POURED CONCRETE OR ASPHALT)**

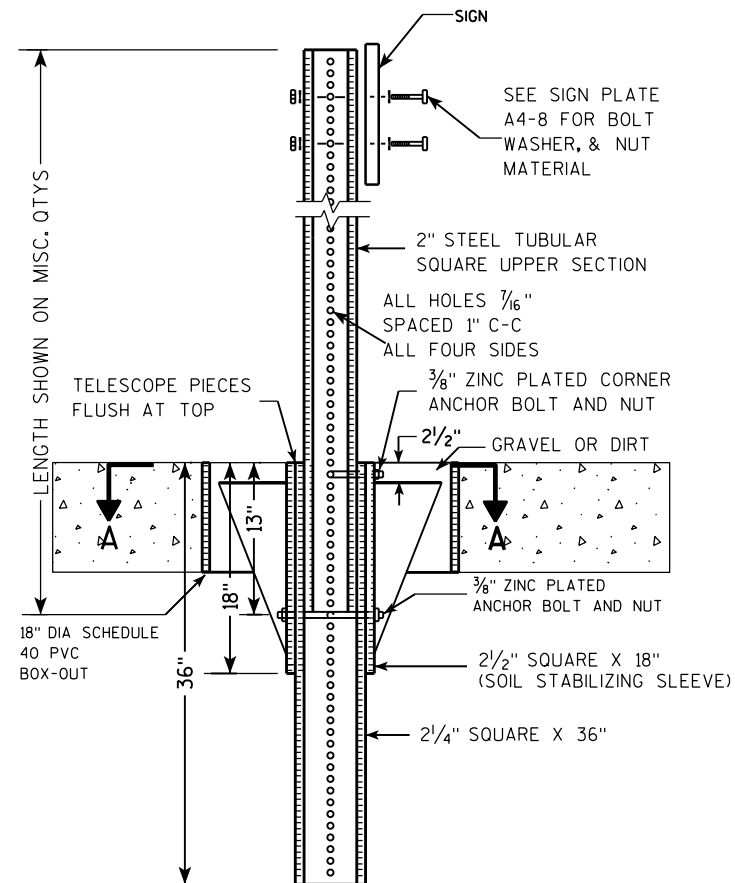

**DETAIL OF TUBULAR STEEL SIGN POST
(IN LOCATIONS OTHER THAN POURED CONCRETE OR ASPHALT)**

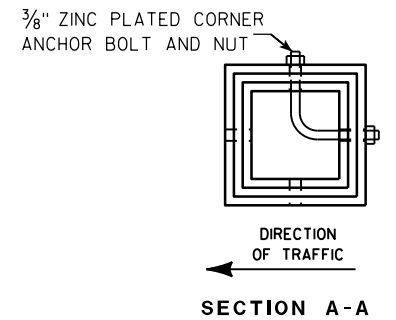
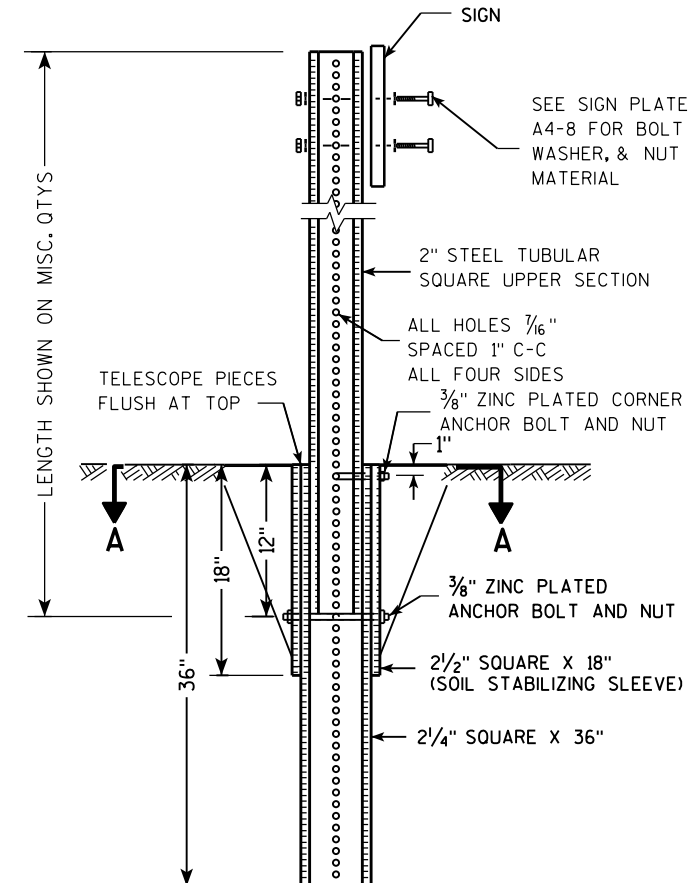

Area of Sign Installation (Sq. Ft.)	Number of Required Posts
9 or less	1
Greater than 9 less than or equal to 18	2
Greater than 18 less than or equal to 27	3

Signs wider than 3 feet or larger than 9 sq. ft shall be mounted on multiple posts (see above table).

**TUBULAR STEEL
SIGN POST
A4-9**

WISCONSIN DEPT OF TRANSPORTATION

APPROVED *Matthew R. Rauch*
for State Traffic Engineer

DATE 2/05/15 PLATE NO. A4-9.9

PROJECT NO:

HWY:

COUNTY:

SHEET NO:

E

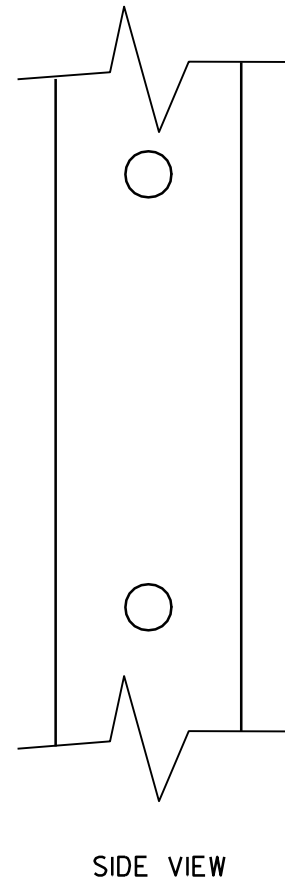
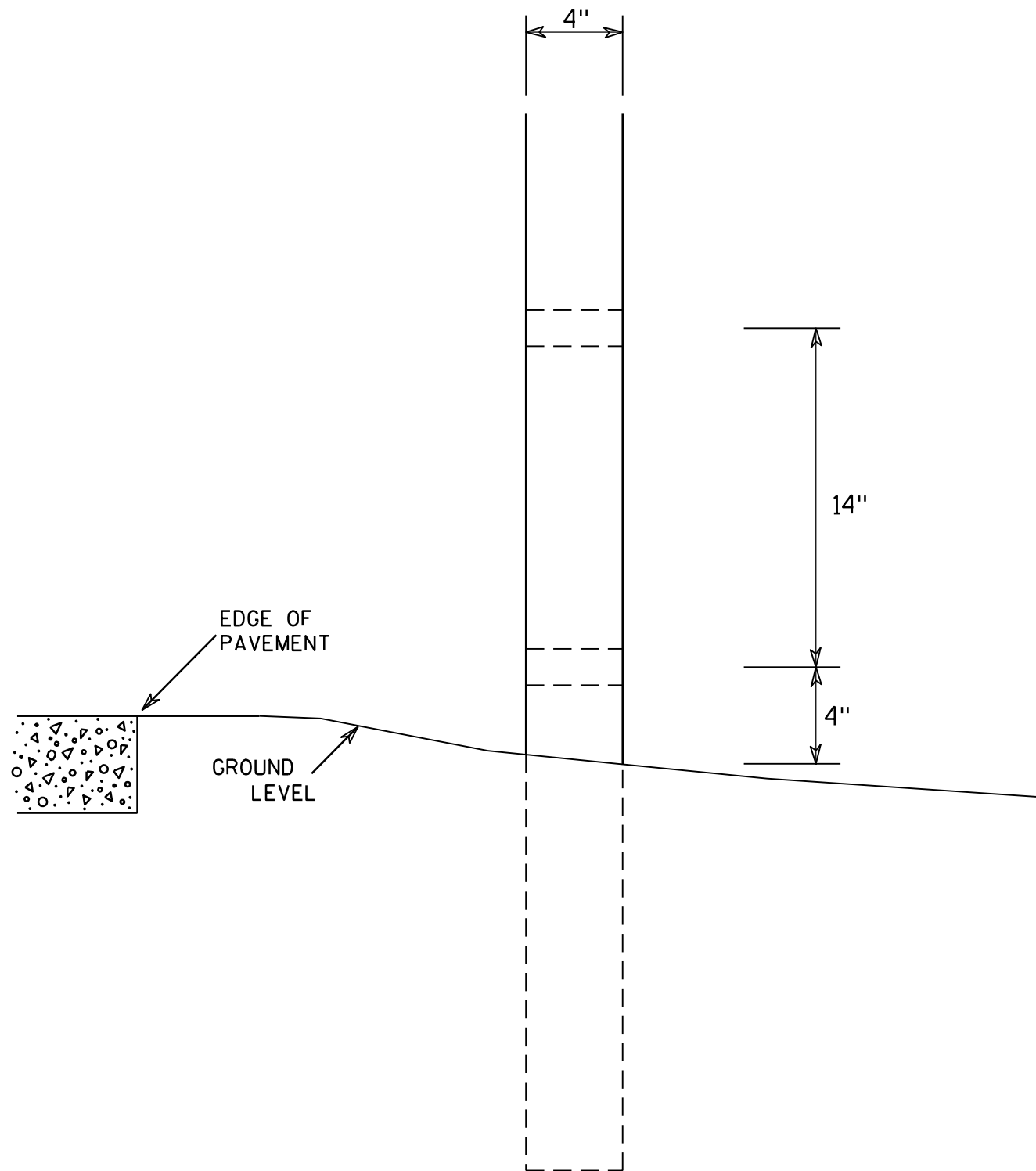

GENERAL NOTES

1. All 4 x 6 Wood Posts shall be modified by having two 1½" diameter holes drilled perpendicular to the roadway centerline.

7

7

4 X 6 WOOD POST MODIFICATIONS	
<i>WISCONSIN DEPT OF TRANSPORTATION</i>	
APPROVED	<i>Chester J Spang</i> for State Traffic Engineer
DATE <u>3/27/97</u>	PLATE NO. <u>A4-11.2</u>

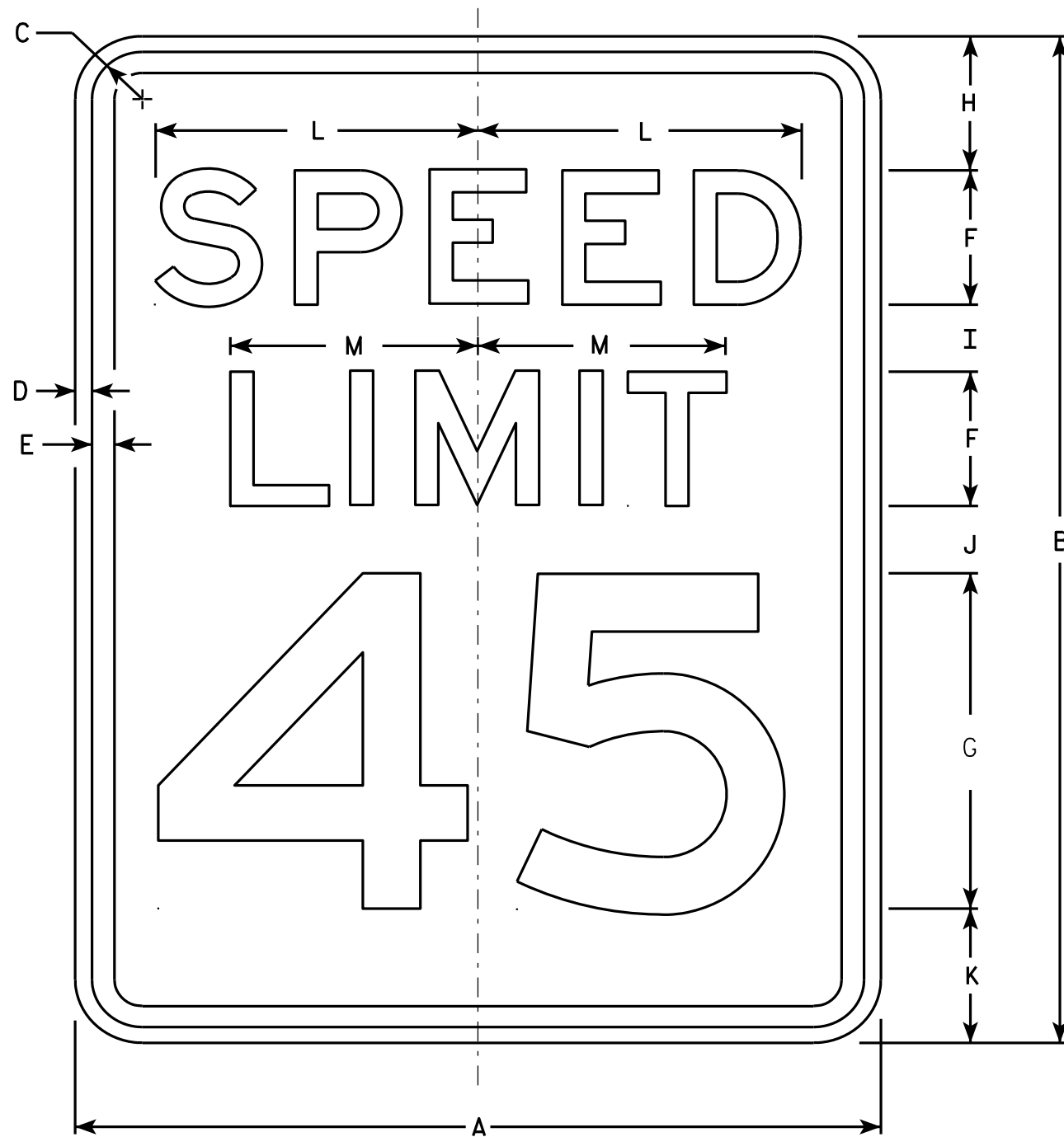

R2-1

NOTES

1. Sign is Type II - Type H Reflective - reference WIS DOT Standard Specification for HIGHWAY and STRUCTURE CONSTRUCTION latest edition.
2. Color:
Background - White
Message - Black
3. Message Series - E
4. Corners may be square or rounded when base material is plywood but borders shall be rounded as shown. When base material is metal, the corners and borders shall be rounded.
5. Substitute appropriate numerals and optically adjust spacing to achieve proper balance.

7

7

SIZE	A	B	C	D	E	F	G	H	I	J	K	L	M	N	O	P	Q	R	S	T	U	V	W	X	Y	Z	Area sq. ft.
1	18	24	1 1/8	3/8	1/2	3	8	3	2	2	3	7 1/4	5 1/2														3.0
2S	24	30	1 1/8	3/8	1/2	4	10	3	2 1/4	3 3/8	3 3/8	9 5/8	7 3/8														5.0
2M	30	36	1 3/8	1/2	5/8	5	12	5	2 1/2	2 1/2	4	12	9 1/4														7.5
3	36	48	1 3/8	1/2	5/8	6	14	6	5	5	6	14 3/8	11														12.0
4	36	48	1 3/8	1/2	5/8	6	14	6	5	5	6	14 3/8	11														12.0
5	48	60	2 1/4	3/4	1	8	20	6	4 1/2	6 3/4	6 3/4	19 1/4	14 5/8														20.0

STANDARD SIGN
R2-1

WISCONSIN DEPT OF TRANSPORTATION

APPROVED *Matthew R. Rauch*
For State Traffic Engineer

DATE 5/26/10 PLATE NO. R2-1.13

PROJECT NO: _____ HWY: _____ COUNTY: _____ SHEET NO: _____ E

NOTES

1. Sign is Type II - Type H Reflective - reference WIS DOT Standard Specification for HIGHWAY and STRUCTURE CONSTRUCTION latest edition.
2. Color:
Background - White
Message - Black
3. Message Series - Line 1 is Series B.
Line 2 is Series C.
Line 3 on plate R3-7R is Series B and Series C on plate R3-7L.
4. Corners may be square or rounded when base material is plywood but borders shall be rounded as shown. When base material is metal, the corners and borders shall be rounded.

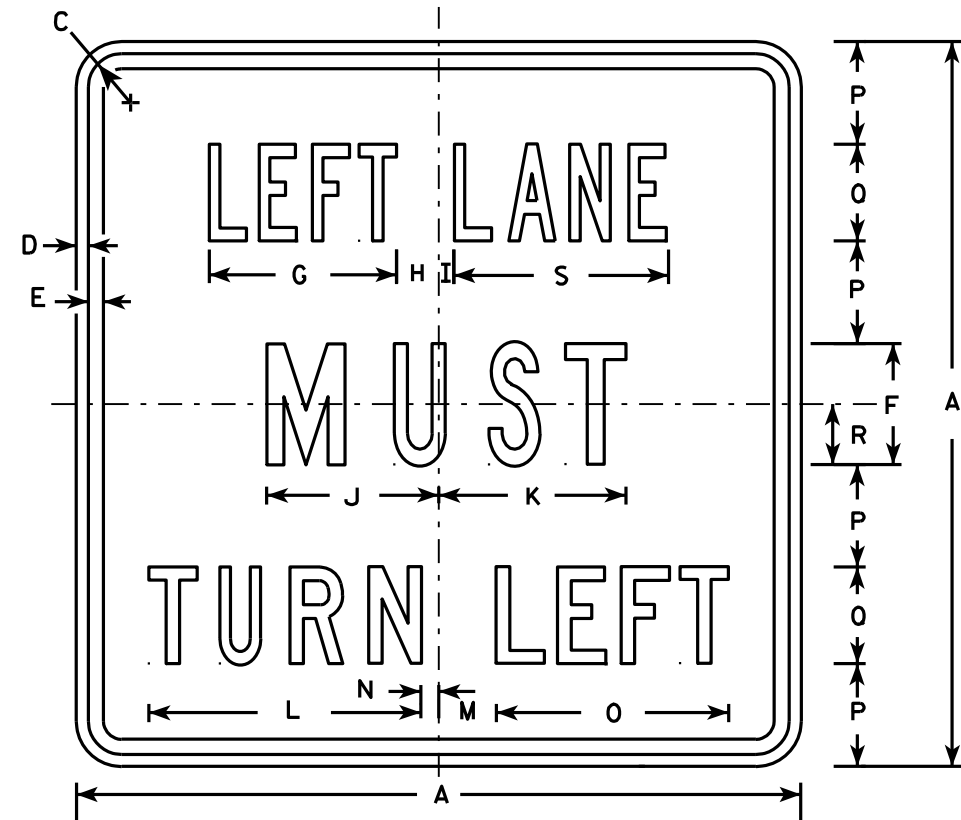

R3-7L

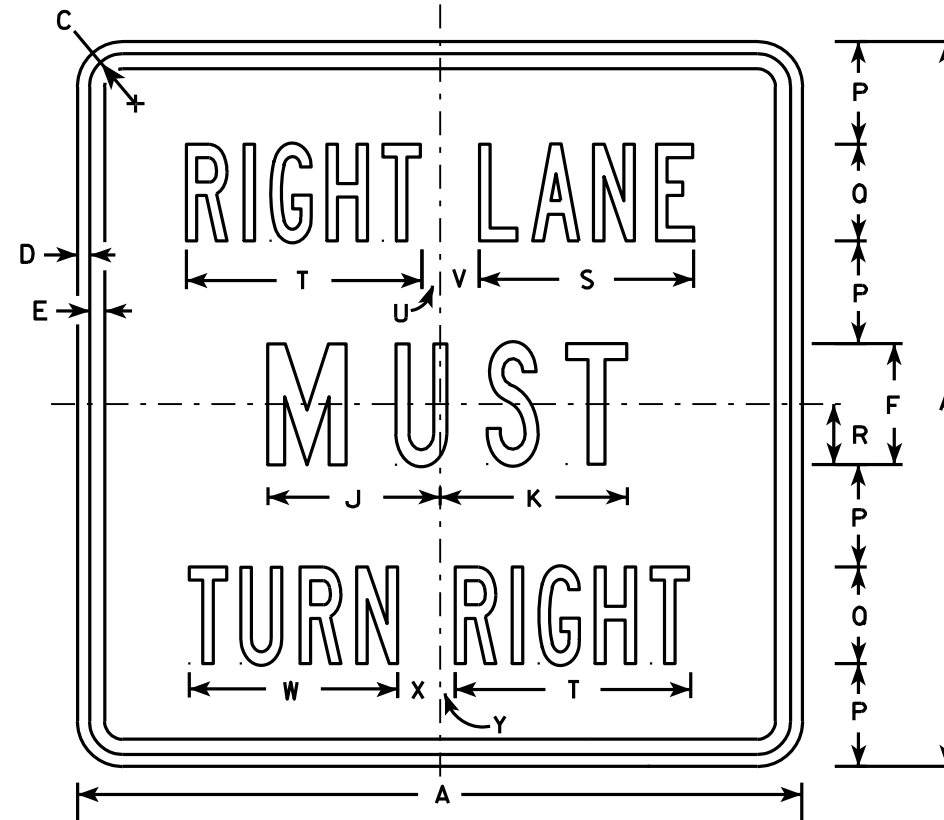

R3-7R

7

7

SIZE	A	B	C	D	E	F	G	H	I	J	K	L	M	N	O	P	Q	R	S	T	U	V	W	X	Y	Z	Area sq. ft.
1	30		1 3/8	1/2	5/8	5	7 3/4	1 3/4	5/8	7 1/8	7 3/4	11 1/4	2 3/8	3/4	9 5/8	4 1/4	4	2 1/2	8 7/8	9 3/4	3/4	1 5/8	8 5/8	1 5/8	5/8		6.25
2S	30		1 3/8	1/2	5/8	5	7 3/4	1 3/4	5/8	7 1/8	7 3/4	11 1/4	2 3/8	3/4	9 5/8	4 1/4	4	2 1/2	8 7/8	9 3/4	3/4	1 5/8	8 5/8	1 5/8	5/8		6.25
2M	30		1 3/8	1/2	5/8	5	7 3/4	1 3/4	5/8	7 1/8	7 3/4	11 1/4	2 3/8	3/4	9 5/8	4 1/4	4	2 1/2	8 7/8	9 3/4	3/4	1 5/8	8 5/8	1 5/8	5/8		6.25
3	36		1 5/8	5/8	3/4	6	9 5/8	2	1 1/8	8 3/4	9	13 1/2	3 7/8	1 1/2	12 1/2	5	5	3	10 5/8	12	7/8	2 1/4	10 5/8	2 1/8	1		9.00
4	48		2 1/4	3/4	1	8	13 1/2	2 3/8	1 1/2	11 1/2	11 7/8	17 3/4	3 5/8	2 1/2	16 3/8	6 1/2	7	4	14 3/8	16 7/8	5/8	3 1/4	15 1/8	2 3/4	1 1/8		16.00
5																											

STANDARD SIGN
R3-7L & R3-7R

WISCONSIN DEPT OF TRANSPORTATION

APPROVED *Matthew R. Rauch*
For State Traffic Engineer

DATE 3/18/2011 PLATE NO. R3-7.3

PROJECT NO: _____ HWY: _____ COUNTY: _____ SHEET NO: _____ E

NOTES

1. Sigs are Type II - Type H Reflective
2. Color:
Background - White
Message - Black
3. Message Series - D
4. Use appropriate Letter for Sign Code
Each letter added makes sign wider. Example R3-8EAR
5. Square footage of sign varies by letters

1 Letter = 3.75 sq ft for Size 2
6.0 sq ft for Size 3
10.0 sq ft for Size 4 or 5

2 Letters = 7.5 sq ft for Size 2
12.0 sq ft for Size 3
20.0 sq ft for Size 4 or 5

3 Letters = 11.25 sq ft for Size 2
18.0 sq ft for Size 3
30.0 sq ft for Size 4 or 5

4 Letters = 15.0 sq ft for Size 2
24.0 sq ft for Size 3
40.0 sq ft for Size 4 or 5

5 Letters = 18.75 sq ft for Size 2
30.0 sq ft for Size 3
50.0 sq ft for Size 4 or 5

6 Letters = 22.5 sq ft for Size 2
36.0 sq ft for Size 3
60.0 sq ft for Size 4 or 5

6. When letters C,D,G,H are used on the Left or Right end of the sign the Sq.Ft. changes.

Add the amounts when these letters are used:

1.25 sq ft for Size 2
1.5 sq ft for Size 3
2.0 sq ft for Size 4 or 5

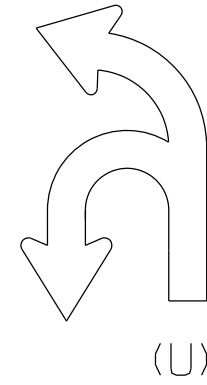
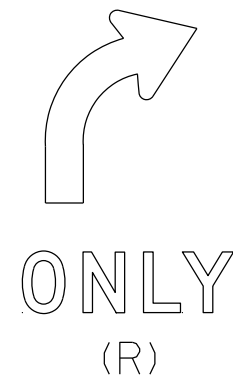
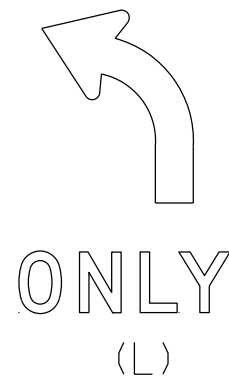
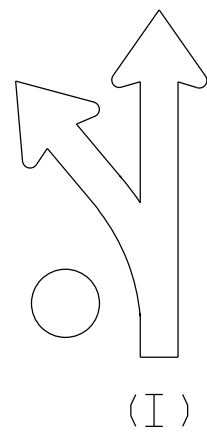
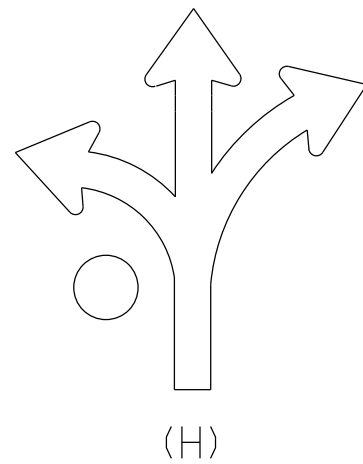
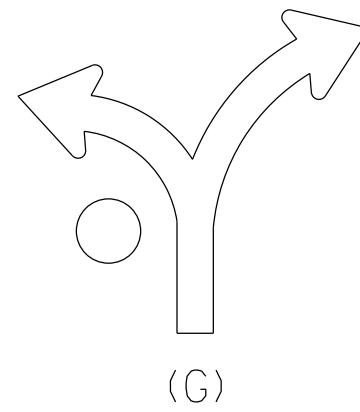
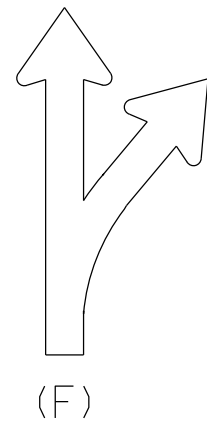
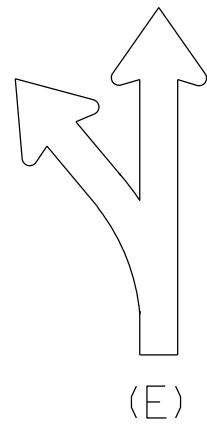
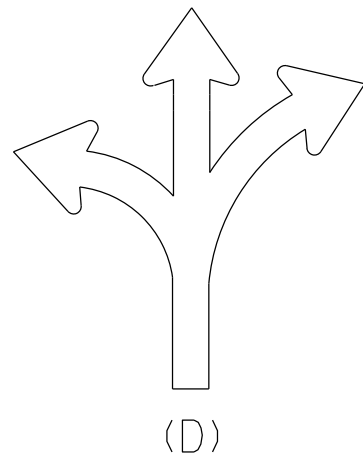
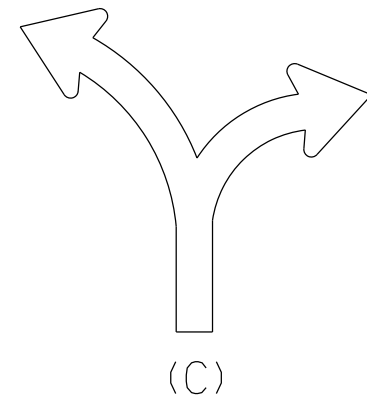
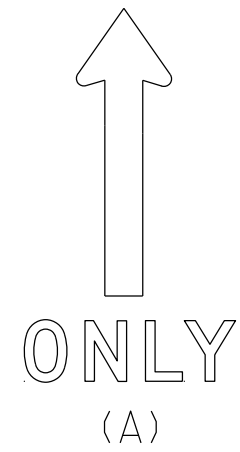

STANDARD SIGN
R3-8 Series

WISCONSIN DEPT OF TRANSPORTATION

APPROVED *Matthew R. Rauch*
for State Traffic Engineer

DATE 5/21/19 PLATE NO. R3-8.1

NOTES

1. Sign is Type II - Type H Reflective
2. Color:
Background - White
Message - Black
3. Message Series - D

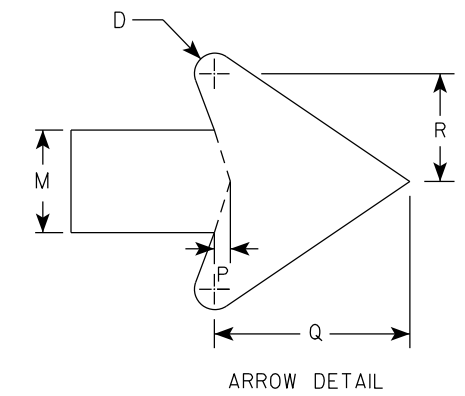
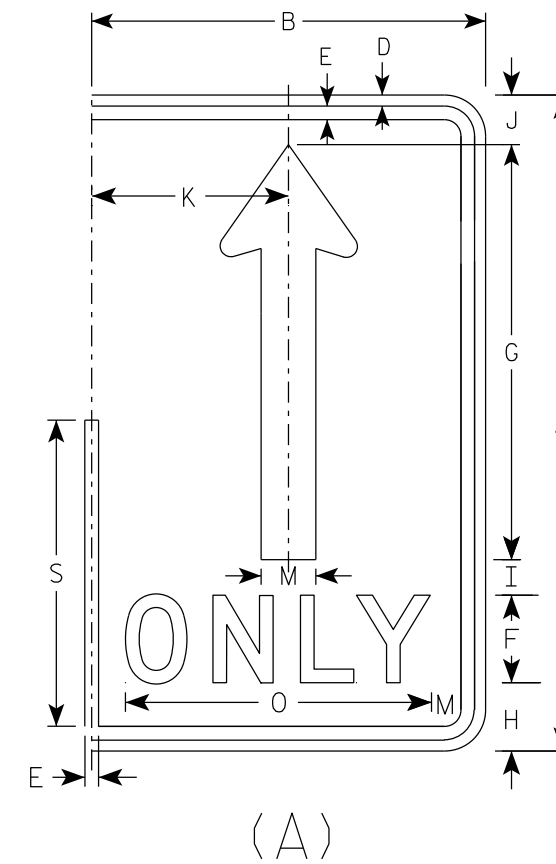
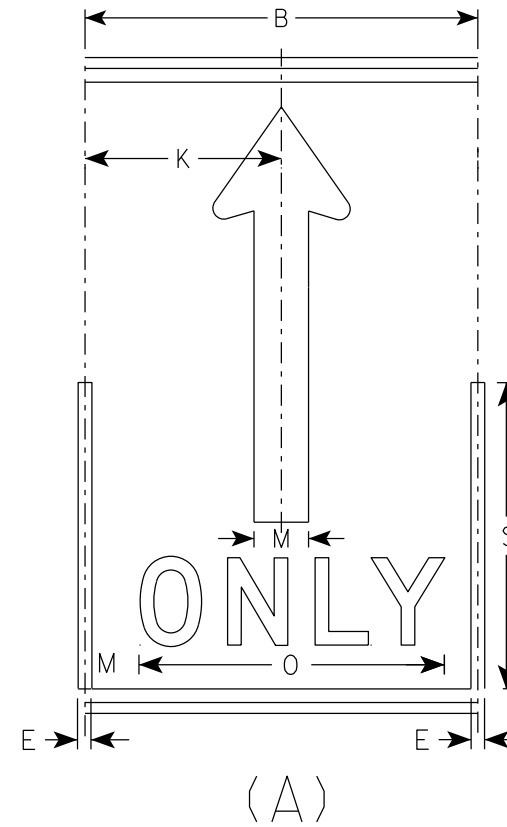
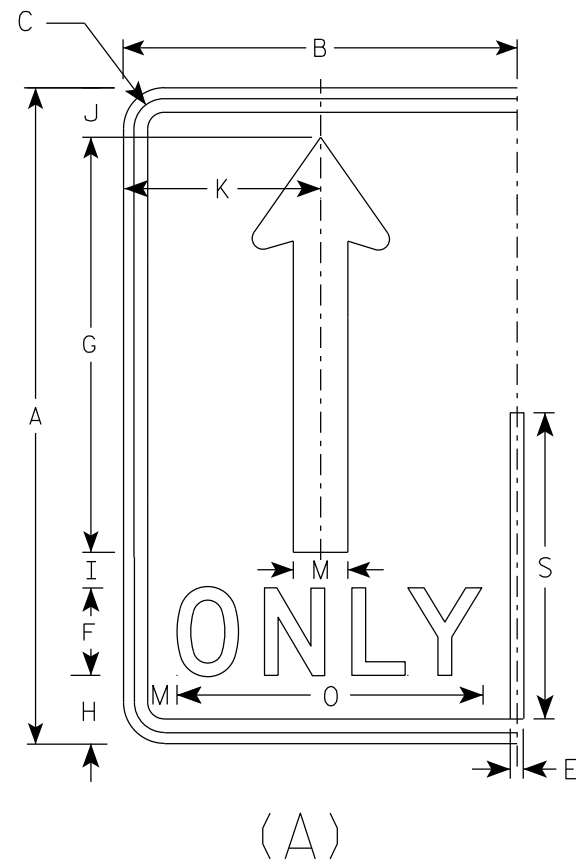

SIZE	A	B	C	D	E	F	G	H	I	J	K	L	M	N	O	P	Q	R	S	T	U	V	W	X	Y	Z	Area sq. ft.
1																											
2S	30	18	1 3/8	1/2	5/8	4	19	3 1/8	1 5/8	2 1/4	9		2 1/2		14	3/8	4 3/4	2 5/8	14								3.75
2M	30	18	1 3/8	1/2	5/8	4	19	3 1/8	1 5/8	2 1/4	9		2 1/2		14	3/8	4 3/4	2 5/8	14								3.75
3	36	24	1 3/8	1/2	5/8	5	22 3/4	3 3/4	1 3/4	2 3/4	12		3		17 5/8	1/2	5 3/4	3 1/8	16 3/4								6.0
4	48	30	2 1/4	3/4	1	6	30 3/8	5 1/8	2 7/8	3 5/8	15		4		21 3/4	5/8	7 5/8	4 1/4	22 3/8								10.0
5	48	30	2 1/4	3/4	1	6	30 3/8	5 1/8	2 7/8	3 5/8	15		4		21 3/4	5/8	7 5/8	4 1/4	22 3/8								10.0

STANDARD SIGN
R3-8 (A) Arrow

WISCONSIN DEPT OF TRANSPORTATION

APPROVED *Matthew R Rauch*
for State Traffic Engineer

DATE 5/21/19 PLATE NO. R3-8.1

PROJECT NO: _____ HWY: _____ COUNTY: _____ SHEET NO: **E**

NOTES

1. Sign is Type II - Type H Reflective
2. Color:
 - Background - White
 - Message - Black
 - Message Series - D

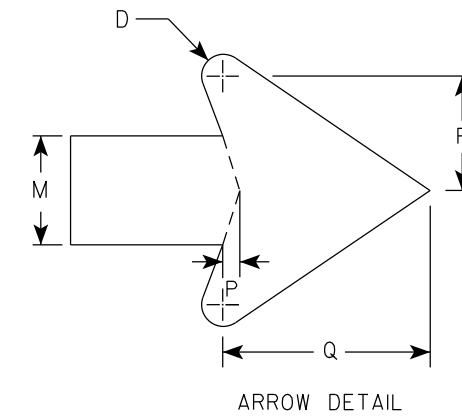
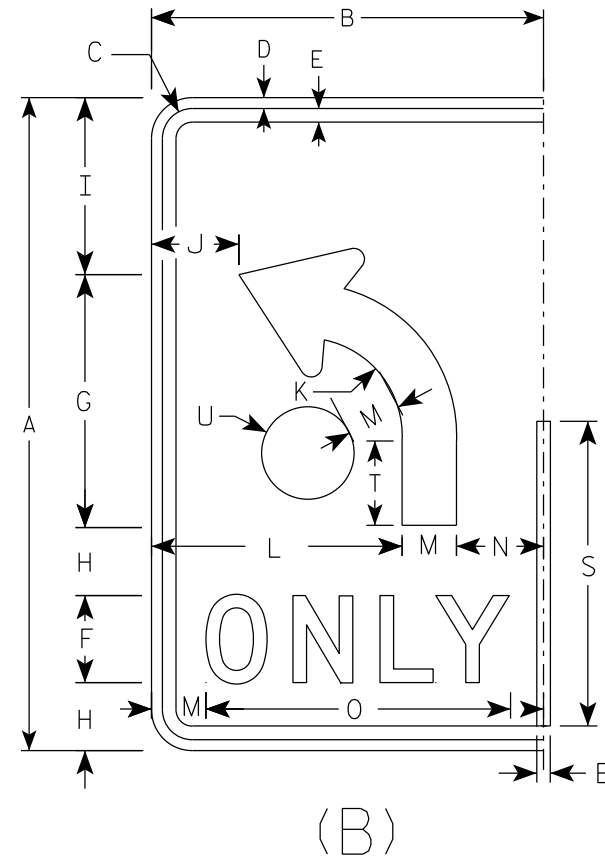

SIZE	A	B	C	D	E	F	G	H	I	J	K	L	M	N	O	P	Q	R	S	T	U	V	W	X	Y	Z	Area sq. ft.
1																											
2S	30	18	1 3/8	1/2	5/8	4	11 5/8	3 1/8	8 1/8	4	4 1/2	11 1/2	2 1/2	4	14	3/8	4 3/4	2 5/8	14	3 7/8	2 1/8						3.75
2M	30	18	1 3/8	1/2	5/8	4	11 5/8	3 1/8	8 1/8	4	4 1/2	11 1/2	2 1/2	4	14	3/8	4 3/4	2 5/8	14	3 7/8	2 1/8						3.75
3	36	24	1 3/8	1/2	5/8	5	14	3 1/2	9 3/4	6	5 3/8	15	3	6	17 5/8	1/2	5 3/4	3 1/8	16 3/4	4 5/8	2 1/2						6.0
4	48	30	2 1/4	3/4	1	6	18 5/8	5 1/8	13 1/8	6 1/8	7 1/4	18	4	8	21 3/4	5/8	7 5/8	4 1/4	22 3/8	6 1/4	3 3/8						10.0
5	48	30	2 1/4	3/4	1	6	18 5/8	5 1/8	13 1/8	6 1/8	7 1/4	18	4	8	21 3/4	5/8	7 5/8	4 1/4	22 3/8	6 1/4	3 3/8						10.0

STANDARD SIGN
R3-8 (B) Arrow

WISCONSIN DEPT OF TRANSPORTATION

APPROVED *Matthew R. Rauch*
for State Traffic Engineer

DATE 5/21/19 PLATE NO. R3-8.1

PROJECT NO:

SHEET NO:

E

NOTES

1. Sign is Type II - Type H Reflective
2. Color:
Background - White
Message - Black
3. Message Series - None

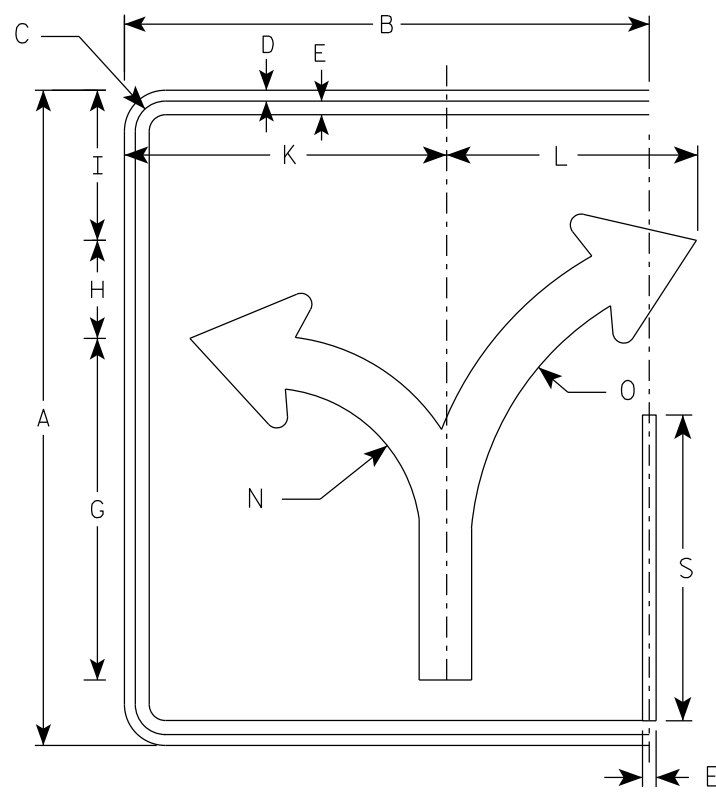

(C)

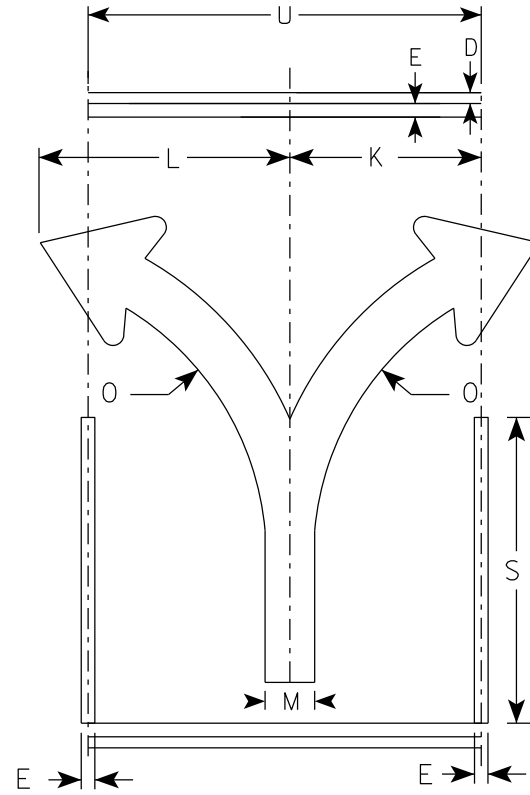

(C)

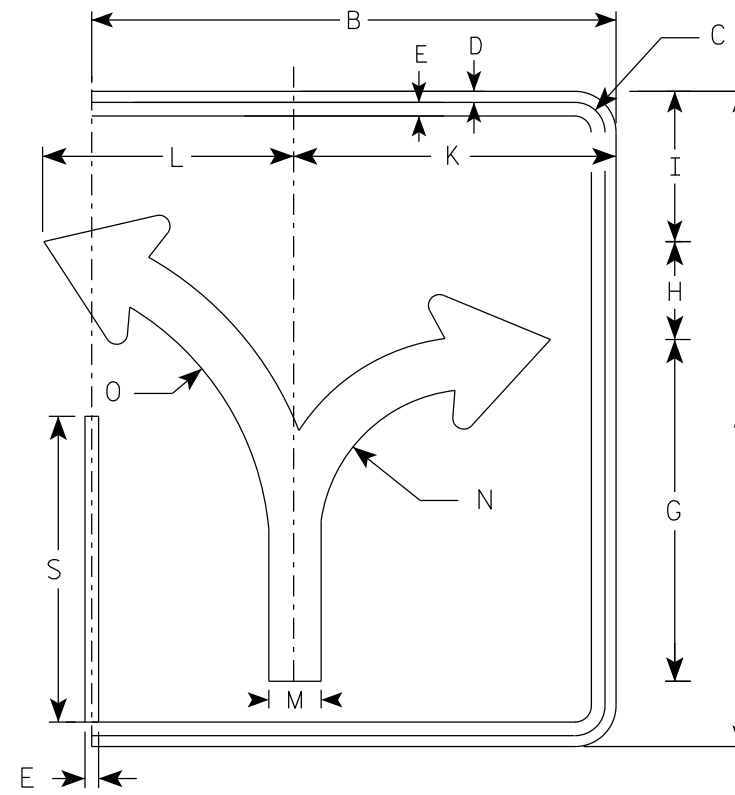

(C)

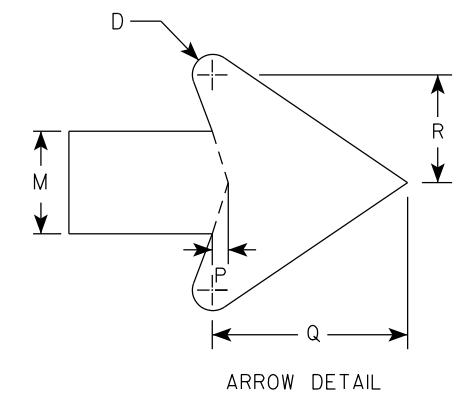

7

7

SIZE	A	B	C	D	E	F	G	H	I	J	K	L	M	N	O	P	Q	R	S	T	U	V	W	X	Y	Z	ENDS	MIDDLE
																											Area sq. ft.	Area sq. ft.
1																												
2S	30	24	1 3/8	1/2	5/8		15 5/8	4 1/2	6 7/8		14 3/4	11 1/2	2 3/8	7	13 1/4	3/8	4 1/2	2 1/2	14		18						5.0	3.75
2M	30	24	1 3/8	1/2	5/8		15 5/8	4 1/2	6 7/8		14 3/4	11 1/2	2 3/8	7	13 1/4	3/8	4 1/2	2 1/2	14		18						5.0	3.75
3	36	30	1 3/8	1/2	5/8		18 3/4	5 1/2	8 1/4		17 1/4	17 1/4	2 7/8	8 3/8	16	1/2	5 1/2	3	16 3/4		24						7.5	6.0
4	48	36	2 1/4	3/4	1		24 7/8	7 1/4	11		23 1/8	18	3 3/4	11 1/8	21 1/4	5/8	7 1/8	4	22 3/8		30						12.0	10.0
5	48	36	2 1/4	3/4	1		24 7/8	7 1/4	11		23 1/8	18	3 3/4	11 1/8	21 1/4	5/8	7 1/8	4	22 3/8		30						12.0	10.0

STANDARD SIGN
R3-8 (C) Arrow

WISCONSIN DEPT OF TRANSPORTATION

APPROVED *Matthew R. Rauch*
for State Traffic Engineer

DATE 5/21/19 PLATE NO. R3-8.1

PROJECT NO: _____ HWY: _____ COUNTY: _____ SHEET NO: **E**

NOTES

1. Sign is Type II - Type H Reflective
2. Color:
Background - White
Message - Black
3. Message Series - None

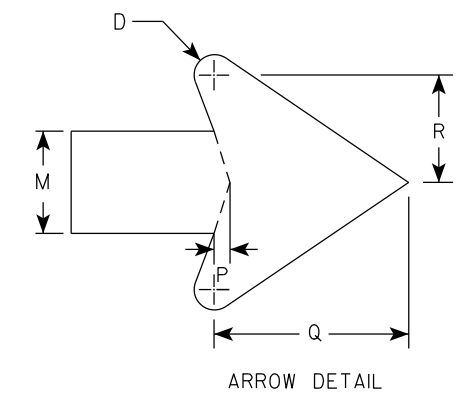
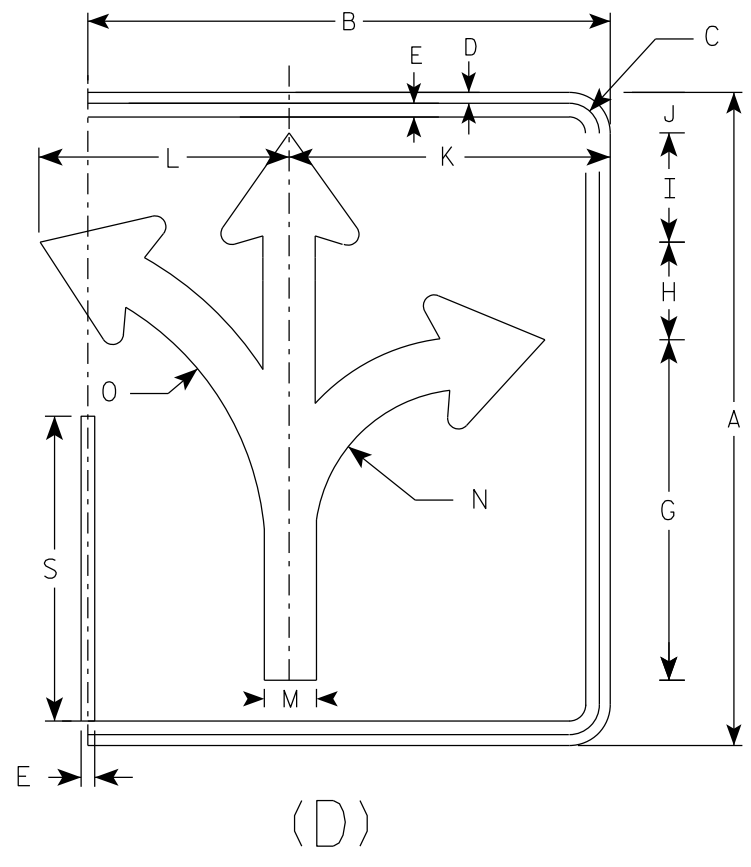
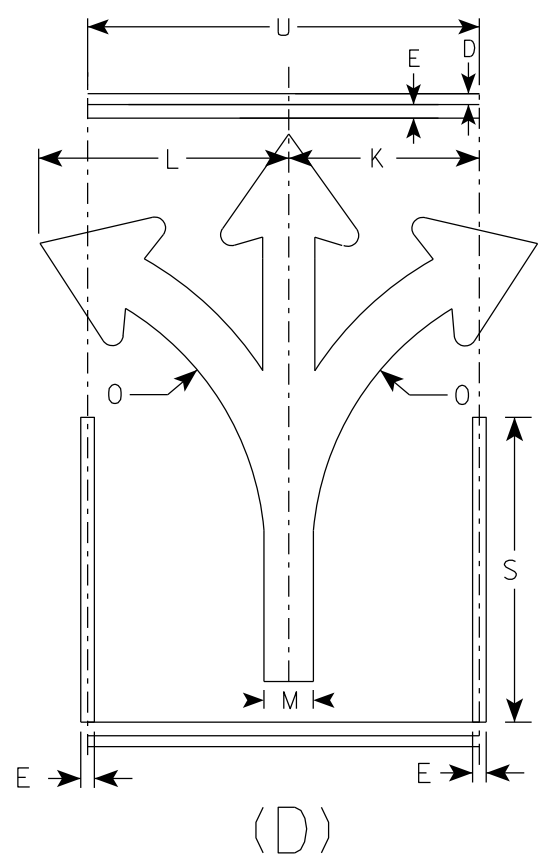
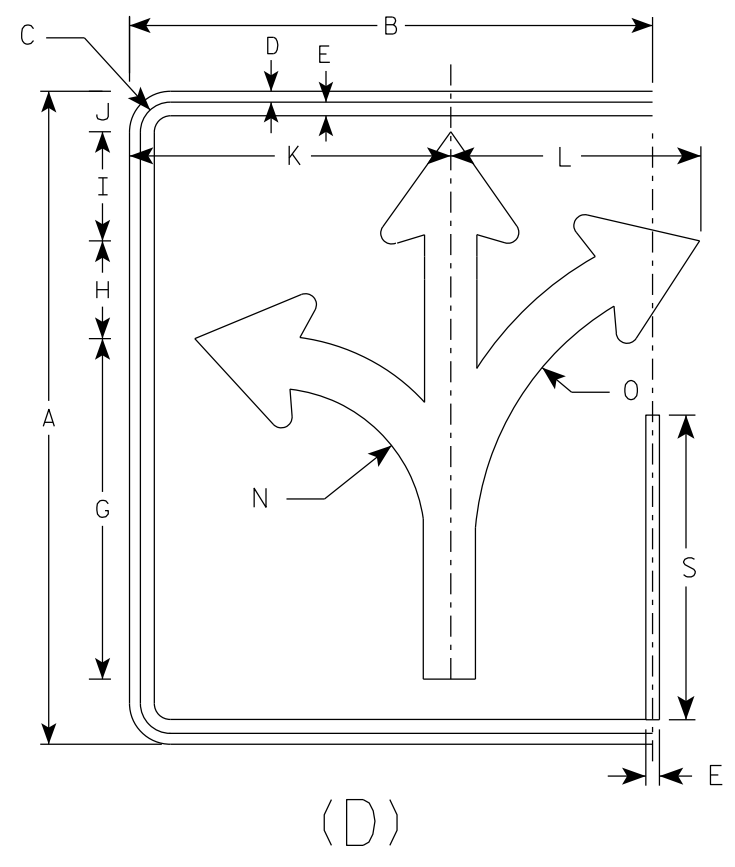

7

7

SIZE	A	B	C	D	E	F	G	H	I	J	K	L	M	N	O	P	Q	R	S	T	U	V	W	X	Y	Z	ENDS	MIDDLE
																											Area sq. ft.	Area sq. ft.
1																												
2S	30	24	1 3/8	1/2	5/8		15 5/8	4 1/2	5	1 7/8	14 3/4	11 1/2	2 3/8	7	13 1/4	3/8	4 1/2	2 1/2	14		18						5.0	3.75
2M	30	24	1 3/8	1/2	5/8		15 5/8	4 1/2	5	1 7/8	14 3/4	11 1/2	2 3/8	7	13 1/4	3/8	4 1/2	2 1/2	14		18					5.0	3.75	
3	36	30	1 3/8	1/2	5/8		18 3/4	5 1/2	6	2 1/4	17 1/4	17 1/4	2 7/8	8 3/8	16	1/2	5 1/2	3	16 3/4		24					7.5	6.0	
4	48	36	2 1/4	3/4	1		24 7/8	7 1/4	7 7/8	3 1/8	23 1/8	18	3 3/4	11 1/8	21 1/4	5/8	7 1/8	4	22 3/8		30					12.0	10.0	
5	48	36	2 1/4	3/4	1		24 7/8	7 1/4	7 7/8	3 1/8	23 1/8	18	3 3/4	11 1/8	21 1/4	5/8	7 1/8	4	22 3/8		30					12.0	10.0	

STANDARD SIGN
R3-8 (D) Arrow

WISCONSIN DEPT OF TRANSPORTATION

APPROVED *Matthew R. Rauch*
for State Traffic Engineer

DATE 5/21/19 PLATE NO. R3-8.1

NOTES

1. Sign is Type II - Type H Reflective
2. Color:
Background - White
Message - Black
3. Message Series - None

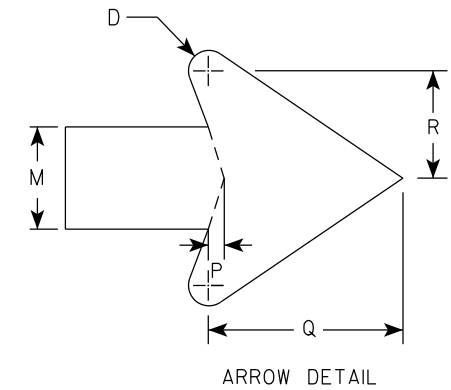
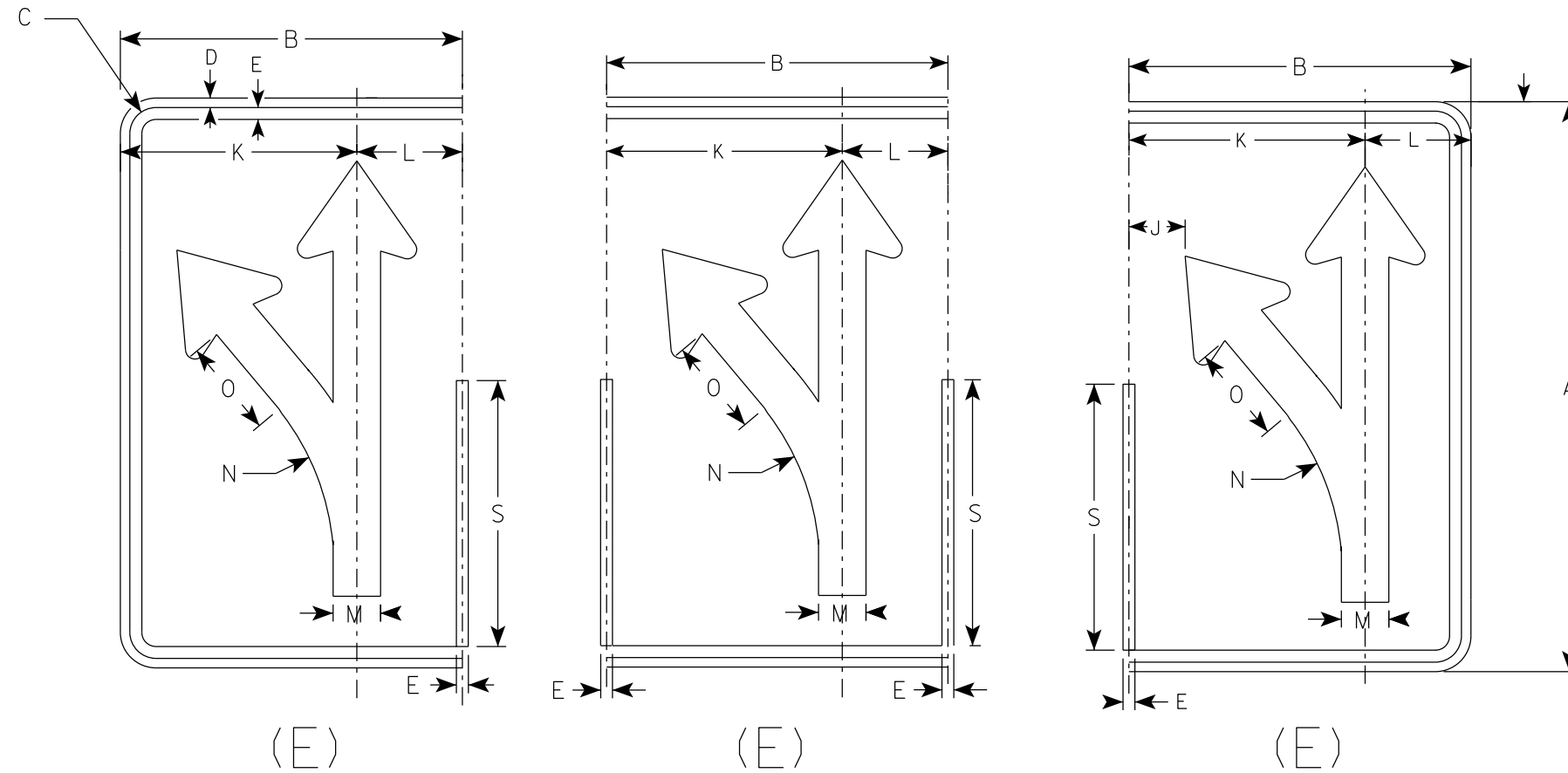

7

7

SIZE	A	B	C	D	E	F	G	H	I	J	K	L	M	N	O	P	Q	R	S	T	U	V	W	X	Y	Z	Area sq. ft.
1																											
2S	30	18	1 3/8	1/2	5/8		18 1/4	4 3/4	3 1/4	3	12 1/2	5 1/2	2 1/2	13 1/4	5 1/8	3/8	4 3/4	2 5/8	14								3.75
2M	30	18	1 3/8	1/2	5/8		18 1/4	4 3/4	3 1/4	3	12 1/2	5 1/2	2 1/2	13 1/4	5 1/8	3/8	4 3/4	2 5/8	14								3.75
3	36	24	1 3/8	1/2	5/8		21 7/8	5 5/8	4	4 7/8	16 1/8	7 3/4	3	15 7/8	6 1/8	1/2	5 3/4	3 1/8	16 3/4								6.0
4	48	30	2 1/4	3/4	1		29 1/8	7 1/2	5 1/4	5 3/8	20 1/2	9 1/2	4	21 1/4	8 1/4	5/8	7 5/8	4 1/4	22 3/8								10.0
5	48	30	2 1/4	3/4	1		29 1/8	7 1/2	5 1/4	5 3/8	20 1/2	9 1/2	4	21 1/4	8 1/4	5/8	7 5/8	4 1/4	22 3/8								10.0

STANDARD SIGN
R3-8 (E) Arrow

WISCONSIN DEPT OF TRANSPORTATION

APPROVED *Matthew R. Rauch*
for State Traffic Engineer

DATE 5/21/19 PLATE NO. R3-8.1

PROJECT NO: _____ HWY: _____ COUNTY: _____ SHEET NO: **E**

NOTES

1. Sign is Type II - Type H Reflective
2. Color:
Background - White
Message - Black
3. Message Series - None

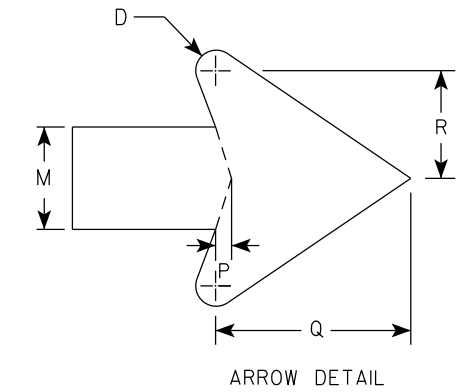
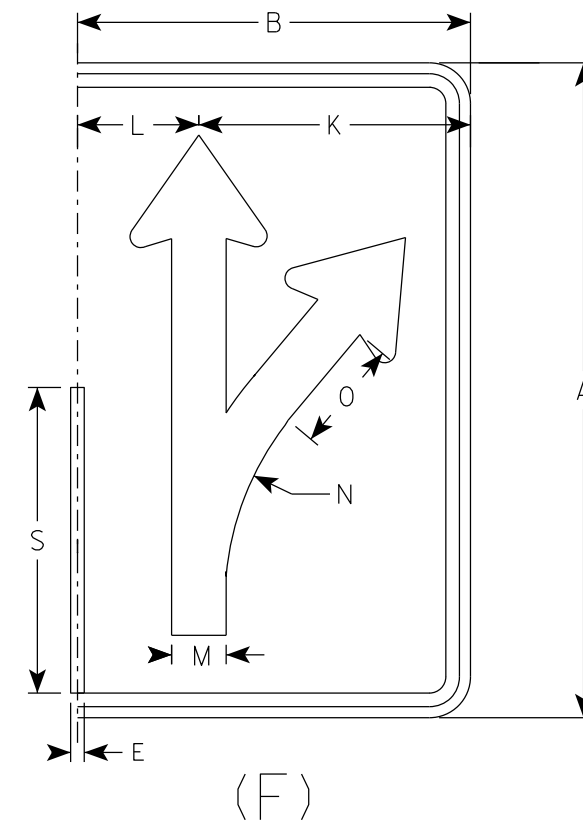
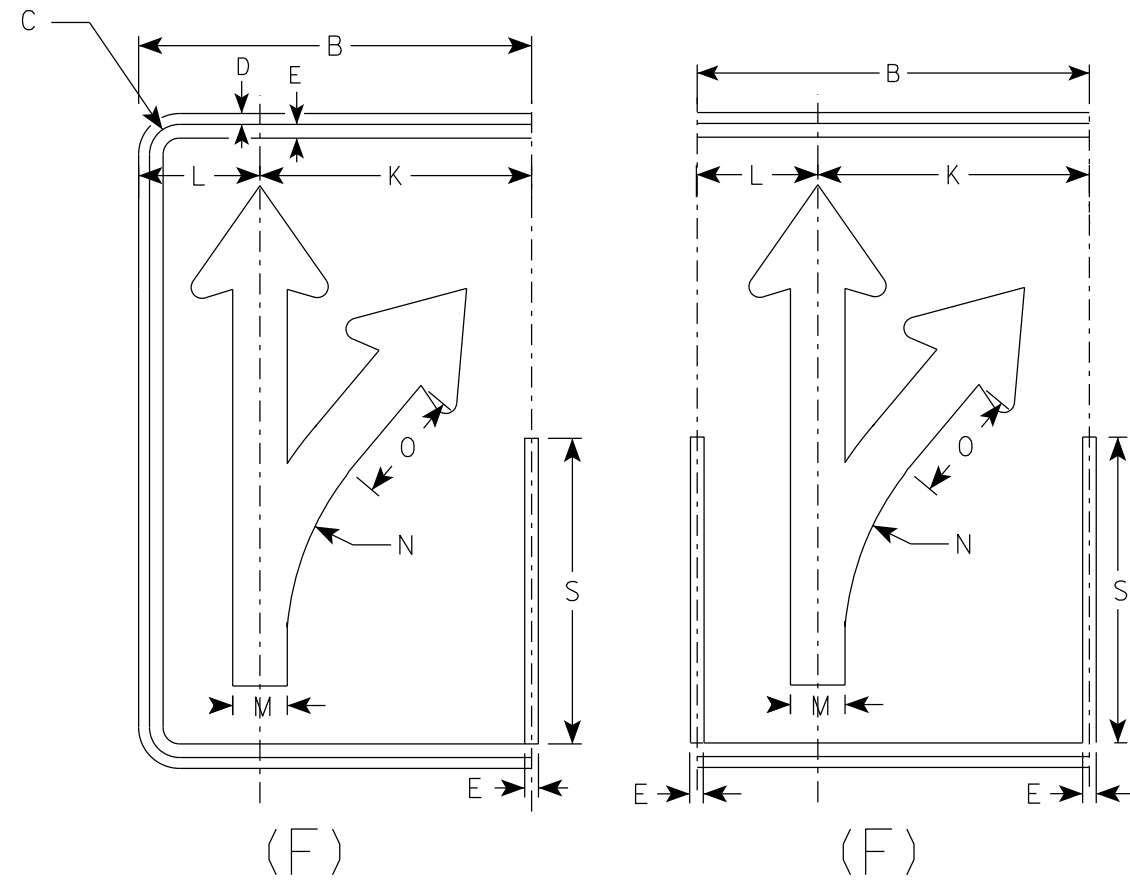

7

7

SIZE	A	B	C	D	E	F	G	H	I	J	K	L	M	N	O	P	Q	R	S	T	U	V	W	X	Y	Z	Area sq. ft.
1																											
2S	30	18	1 3/8	1/2	5/8		18 1/4	4 3/4	3 1/4	3	12 1/2	5 1/2	2 1/2	13 1/4	5 1/8	3/8	4 3/4	2 5/8	14								3.75
2M	30	18	1 3/8	1/2	5/8		18 1/4	4 3/4	3 1/4	3	12 1/2	5 1/2	2 1/2	13 1/4	5 1/8	3/8	4 3/4	2 5/8	14								3.75
3	36	24	1 3/8	1/2	5/8		21 7/8	5 5/8	4	4 7/8	16 1/8	7 3/4	3	15 7/8	6 1/8	1/2	5 3/4	3 1/8	16 3/4								6.0
4	48	30	2 1/4	3/4	1		29 1/8	7 1/2	5 1/4	5 3/8	20 1/2	9 1/2	4	21 1/4	8 1/4	5/8	7 5/8	4 1/4	22 3/8								10.0
5	48	30	2 1/4	3/4	1		29 1/8	7 1/2	5 1/4	5 3/8	20 1/2	9 1/2	4	21 1/4	8 1/4	5/8	7 5/8	4 1/4	22 3/8								10.0

STANDARD SIGN
R3-8 (F) Arrow

WISCONSIN DEPT OF TRANSPORTATION

APPROVED *Matthew R. Rauch*
for State Traffic Engineer

DATE 5/21/19 PLATE NO. R3-8.1

PROJECT NO: _____ HWY: _____ COUNTY: _____ SHEET NO: **E**

NOTES

1. Sign is Type II - Type H Reflective
2. Color:
Background - White
Message - Black
3. Message Series - None

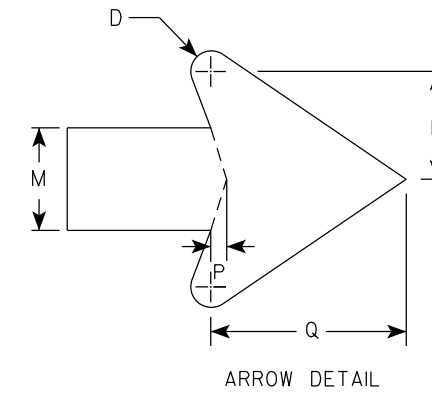
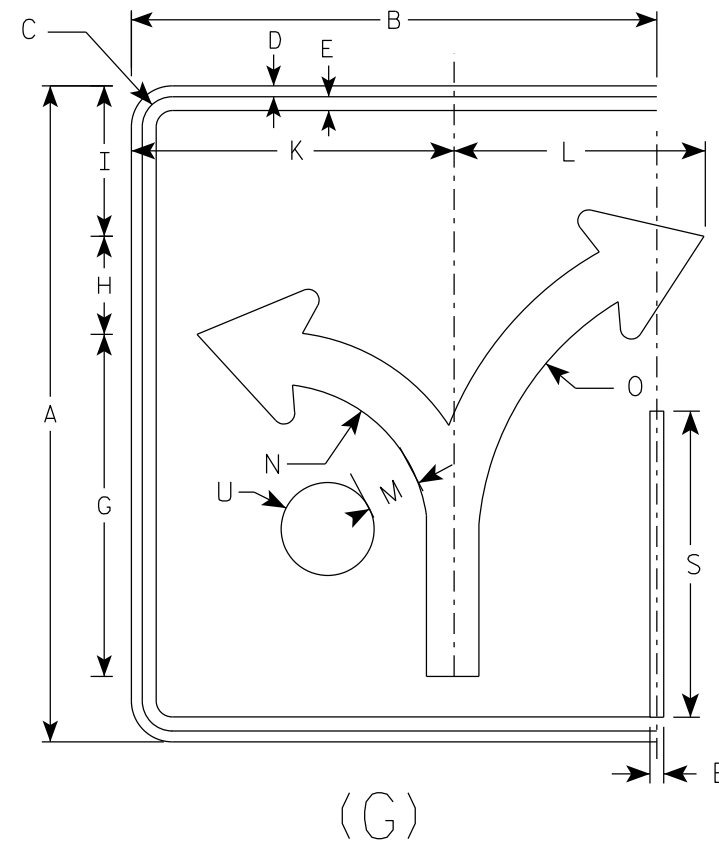

SIZE	A	B	C	D	E	F	G	H	I	J	K	L	M	N	O	P	Q	R	S	T	U	V	W	X	Y	Z	Area sq. ft.
1																											
2S	30	24	1 3/8	1/2	5/8		15 5/8	4 1/2	6 7/8		14 3/4	11 1/2	2 3/8	7	13 1/4	3/8	4 1/2	2 1/2	14		2 1/8						5.0
2M	30	24	1 3/8	1/2	5/8		15 5/8	4 1/2	6 7/8		14 3/4	11 1/2	2 3/8	7	13 1/4	3/8	4 1/2	2 1/2	14		2 1/8						5.0
3	36	30	1 3/8	1/2	5/8		18 3/4	5 1/2	8 1/4		17 1/4	17 1/4	2 7/8	8 3/8	16	1/2	5 1/2	3	16 3/4		2 1/2						7.5
4	48	36	2 1/4	3/4	1		24 7/8	7 1/4	11		23 1/8	18	3 3/4	11 1/8	21 1/4	5/8	7 1/8	4	22 3/8		3 3/8						12.0
5	48	36	2 1/4	3/4	1		24 7/8	7 1/4	11		23 1/8	18	3 3/4	11 1/8	21 1/4	5/8	7 1/8	4	22 3/8		3 3/8						12.0

STANDARD SIGN
R3-8 (G) Arrow

WISCONSIN DEPT OF TRANSPORTATION

APPROVED *Matthew R Rauch*
For State Traffic Engineer

DATE 5/21/19 PLATE NO. R3-8.1

PROJECT NO: _____ HWY: _____ COUNTY: _____ SHEET NO: **E**

7

7

NOTES

1. Sign is Type II - Type H Reflective
2. Color:
Background - White
Message - Black
3. Message Series - None

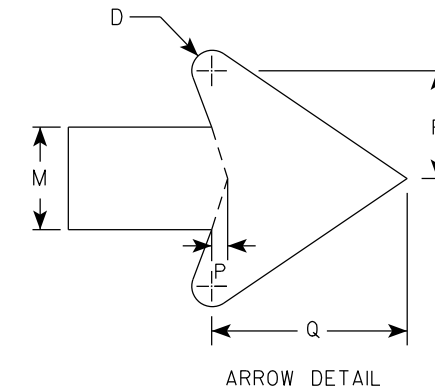
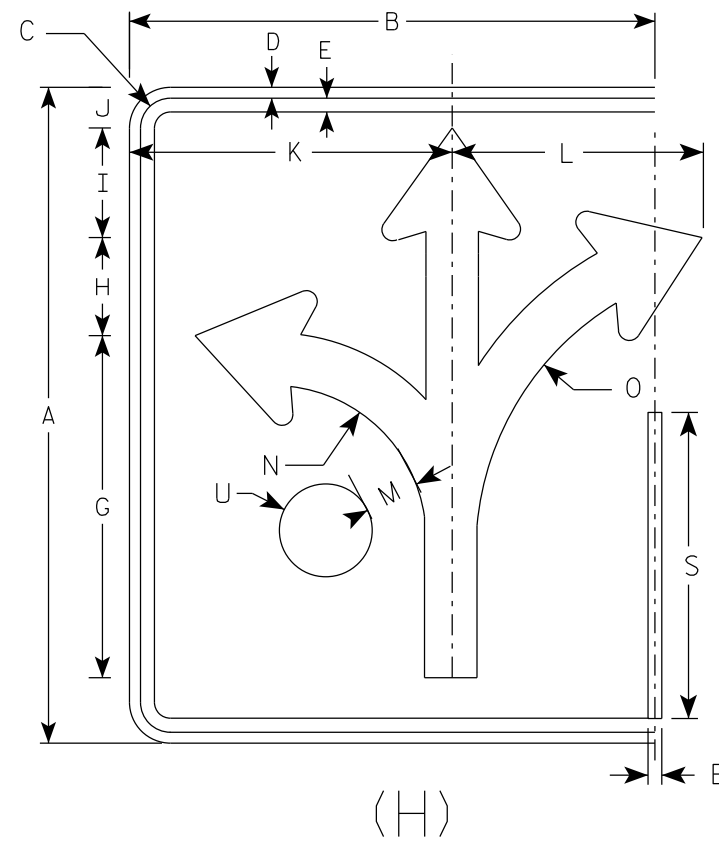

7

7

SIZE	A	B	C	D	E	F	G	H	I	J	K	L	M	N	O	P	Q	R	S	T	U	V	W	X	Y	Z	Area sq. ft.
1																											
2S	30	24	1 3/8	1/2	5/8		15 5/8	4 1/2	5	1 7/8	14 3/4	11 1/2	2 3/8	7	13 1/4	3/8	4 1/2	2 1/2	14		2 1/8						5.0
2M	30	24	1 3/8	1/2	5/8		15 5/8	4 1/2	5	1 7/8	14 3/4	11 1/2	2 3/8	7	13 1/4	3/8	4 1/2	2 1/2	14		2 1/8						5.0
3	36	30	1 3/8	1/2	5/8		18 3/4	5 1/2	6	3 1/8	17 1/4	17 1/4	2 7/8	8 3/8	16	1/2	5 1/2	3	16 3/4		2 1/2						7.5
4	48	36	2 1/4	3/4	1		24 7/8	7 1/4	7 7/8	3 1/8	23 1/8	18	3 3/4	11 1/8	21 1/4	5/8	7 1/8	4	22 3/8		3 3/8						12.0
5	48	36	2 1/4	3/4	1		24 7/8	7 1/4	7 7/8	3 1/8	23 1/8	18	3 3/4	11 1/8	21 1/4	5/8	7 1/8	4	22 3/8		3 3/8						12.0

STANDARD SIGN
R3-8 (H) Arrow

WISCONSIN DEPT OF TRANSPORTATION

APPROVED *Matthew R Rauch*
For State Traffic Engineer

DATE 5/21/19 PLATE NO. R3-8.1

PROJECT NO: _____ HWY: _____ COUNTY: _____ SHEET NO: **E**

NOTES

1. Sign is Type II - Type H Reflective
2. Color:
Background - White
Message - Black
3. Message Series - None

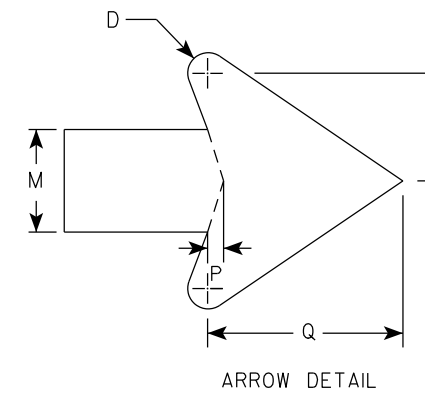
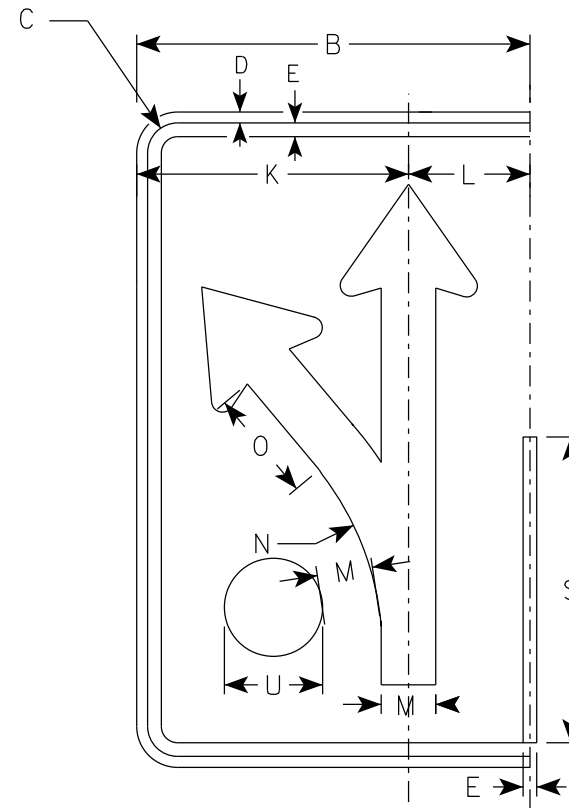

(I)

SIZE	A	B	C	D	E	F	G	H	I	J	K	L	M	N	O	P	Q	R	S	T	U	V	W	X	Y	Z	Area sq. ft.
1																											
2S	30	18	1 3/8	1/2	5/8		18 1/4	4 3/4	3 1/4	3	12 1/2	5 1/2	2 1/2	13 1/4	5 1/8	3/8	4 3/4	2 5/8	14		2 1/8						3.75
2M	30	18	1 3/8	1/2	5/8		18 1/4	4 3/4	3 1/4	3	12 1/2	5 1/2	2 1/2	13 1/4	5 1/8	3/8	4 3/4	2 5/8	14		2 1/8						3.75
3	36	24	1 3/8	1/2	5/8		21 7/8	5 5/8	4	4 7/8	16 1/8	7 3/4	3	15 7/8	6 1/8	1/2	5 3/4	3 1/8	16 3/4		2 1/2						6.0
4	48	30	2 1/4	3/4	1		29 1/8	7 1/2	5 1/4	5 3/8	20 1/2	9 1/2	4	21 1/4	8 1/4	5/8	7 5/8	4 1/4	22 3/8		3 3/8						10.0
5	48	30	2 1/4	3/4	1		29 1/8	7 1/2	5 1/4	5 3/8	20 1/2	9 1/2	4	21 1/4	8 1/4	5/8	7 5/8	4 1/4	22 3/8		3 3/8						10.0

STANDARD SIGN
R3-8 (I) Arrow

WISCONSIN DEPT OF TRANSPORTATION

APPROVED *Matthew R. Rauch*
for State Traffic Engineer

DATE 5/21/19 PLATE NO. R3-8.1

PROJECT NO: _____ HWY: _____ COUNTY: _____ SHEET NO: **E**

NOTES

1. Sign is Type II - Type H Reflective
2. Color:
Background - White
Message - Black
3. Message Series - D

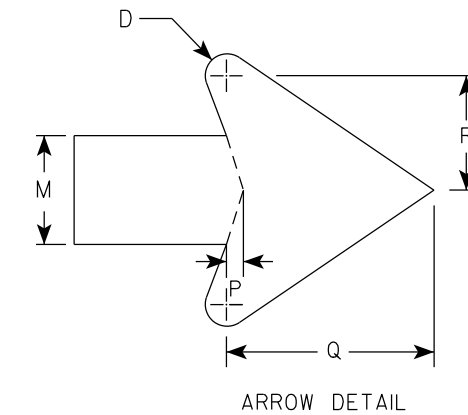
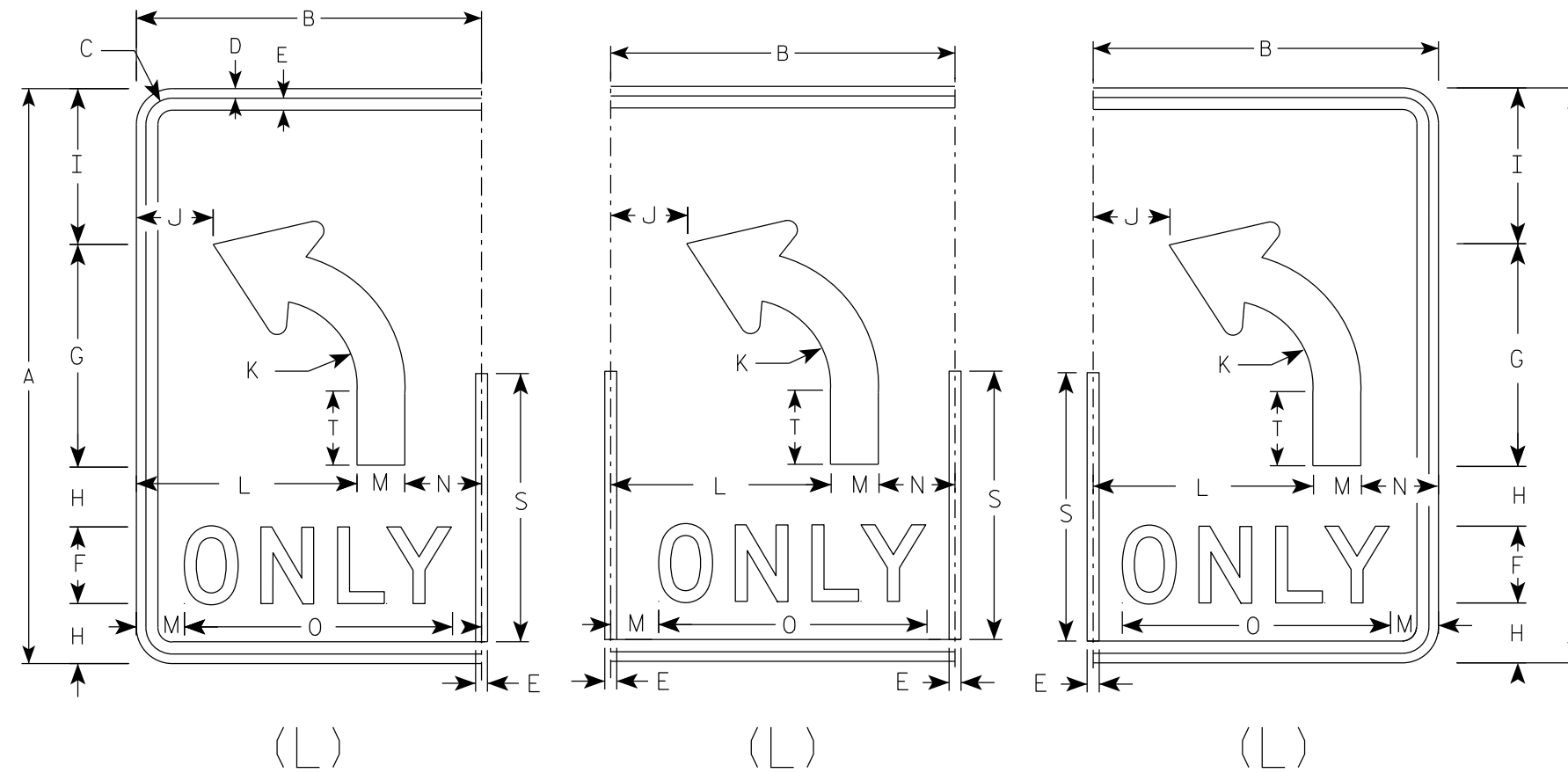

7

7

SIZE	A	B	C	D	E	F	G	H	I	J	K	L	M	N	O	P	Q	R	S	T	U	V	W	X	Y	Z	Area sq. ft.
1																											
2S	30	18	1 3/8	1/2	5/8	4	11 5/8	3 1/8	8 1/8	4	4 1/2	11 1/2	2 1/2	4	14	3/8	4 3/4	2 5/8	14	3 7/8							3.75
2M	30	18	1 3/8	1/2	5/8	4	11 5/8	3 1/8	8 1/8	4	4 1/2	11 1/2	2 1/2	4	14	3/8	4 3/4	2 5/8	14	3 7/8							3.75
3	36	24	1 3/8	1/2	5/8	5	14	3 1/2	9 3/4		5 3/8	15	3	6	17 5/8	1/2	5 3/4	3 1/8	16 3/4	4 5/8							6.0
4	48	30	2 1/4	3/4	1	6	18 5/8	5 1/8	13 1/8	6 1/8	7 1/4	18	4	8	21 3/4	5/8	7 5/8	4 1/4	22 3/8	6 1/4							10.0
5	48	30	2 1/4	3/4	1	6	18 5/8	5 1/8	13 1/8	6 1/8	7 1/4	18	4	8	21 3/4	5/8	7 5/8	4 1/4	22 3/8	6 1/4							10.0

STANDARD SIGN
R3-8 (L) Arrow

WISCONSIN DEPT OF TRANSPORTATION

APPROVED *Matthew R. Rauch*
for State Traffic Engineer

DATE 5/21/19 PLATE NO. R3-8.1

PROJECT NO:

SHEET NO:

E

NOTES

1. Sign is Type II - Type H Reflective
2. Color:
Background - White
Message - Black
3. Message Series - D

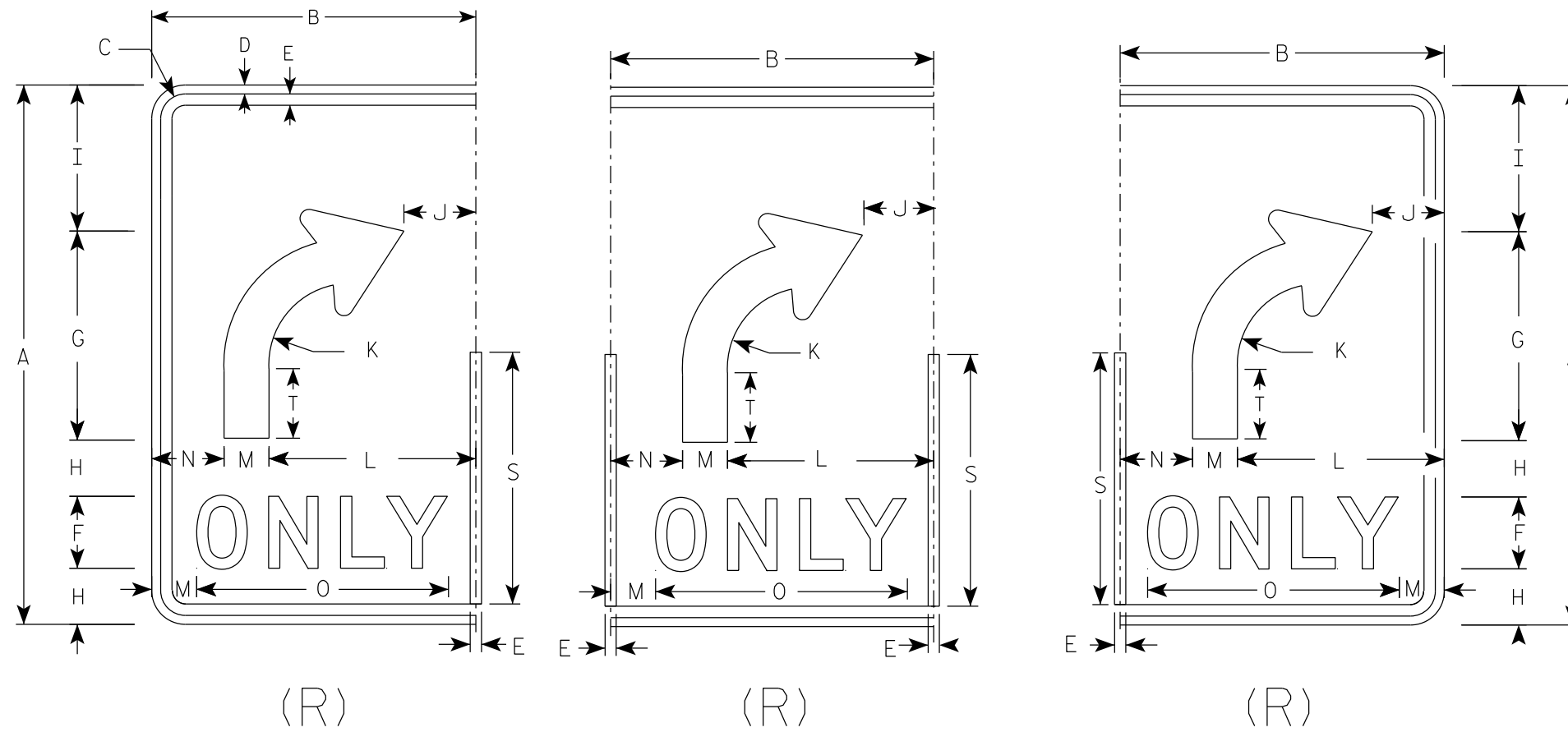

7

7

SIZE	A	B	C	D	E	F	G	H	I	J	K	L	M	N	O	P	Q	R	S	T	U	V	W	X	Y	Z	Area sq. ft.
1																											
2S	30	18	1 3/8	1/2	5/8	4	11 5/8	3 1/8	8 1/8	4	4 1/2	11 1/2	2 1/2	4	14	3/8	4 3/4	2 5/8	14	3 7/8							3.75
2M	30	18	1 3/8	1/2	5/8	4	11 5/8	3 1/8	8 1/8	4	4 1/2	11 1/2	2 1/2	4	14	3/8	4 3/4	2 5/8	14	3 7/8							3.75
3	36	24	1 3/8	1/2	5/8	5	14	3 1/2	9 3/4	6	5 3/8	15	3	6	17 5/8	1/2	5 3/4	3 1/8	16 3/4	4 5/8							6.0
4	48	30	2 1/4	3/4	1	6	18 5/8	5 1/8	13 1/8	6 1/8	7 1/4	18	4	8	21 3/4	5/8	7 5/8	4 1/4	22 3/8	6 1/4							10.0
5	48	30	2 1/4	3/4	1	6	18 5/8	5 1/8	13 1/8	6 1/8	7 1/4	18	4	8	21 3/4	5/8	7 5/8	4 1/4	22 3/8	6 1/4							10.0

STANDARD SIGN
R3-8 (R) Arrow

WISCONSIN DEPT OF TRANSPORTATION

APPROVED *Matthew R. Rauch*
for State Traffic Engineer

DATE 5/21/19 PLATE NO. R3-8.1

NOTES

1. Sign is Type II - Type H Reflective
2. Color:
Background - White
Message - Black
3. Message Series - None

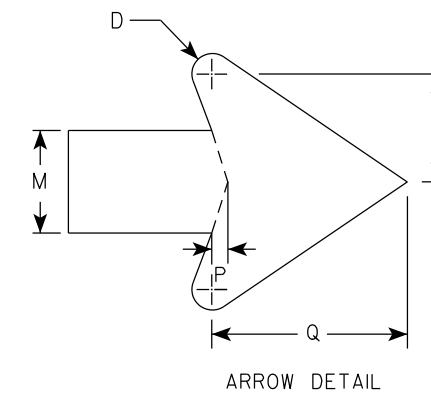
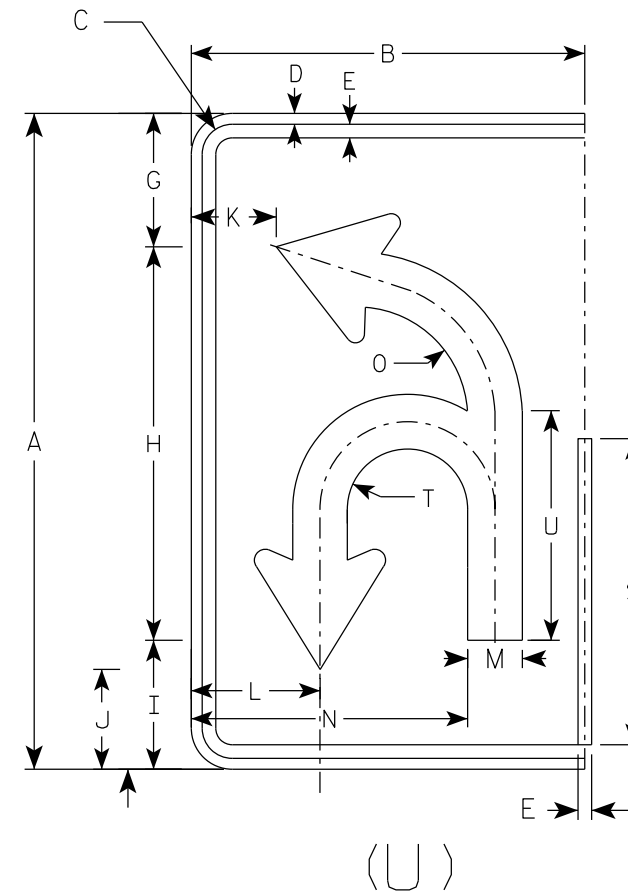

SIZE	A	B	C	D	E	F	G	H	I	J	K	L	M	N	O	P	Q	R	S	T	U	V	W	X	Y	Z	Area sq. ft.
1																											
2S	30	18	1 3/8	1/2	5/8		6 1/8	18	5 7/8	4 5/8	3 7/8	5 7/8	2 1/2	12 5/8	5 1/8	3/8	4 3/4	2 5/8	14	2 3/4	10 1/2						3.75
2M	30	18	1 3/8	1/2	5/8		6 1/8	18	5 7/8	4 5/8	3 7/8	5 7/8	2 1/2	12 5/8	5 1/8	3/8	4 3/4	2 5/8	14	2 3/4	10 1/2						3.75
3	36	24	1 3/8	1/2	5/8		21 7/8	21 5/8	7 1/8	5 1/2	5 7/8	8 1/4	3	16 3/8	6 1/8	1/2	5 3/4	3 1/8	16 3/4	3 1/4	12 5/8						6.0
4	48	30	2 1/4	3/4	1		29 1/8	28 3/4	9 3/8	7 1/4	6 7/8	10	4	20 7/8	8 1/8	5/8	7 5/8	4 1/4	22 3/8	4 3/8	16 3/4						10.0
5	48	30	2 1/4	3/4	1		29 1/8	28 3/4	9 3/8	7 1/4	6 7/8	10	4	20 7/8	8 1/8	5/8	7 5/8	4 1/4	22 3/8	4 3/8	16 3/4						10.0

STANDARD SIGN
R3-8 (U) Arrow

WISCONSIN DEPT OF TRANSPORTATION

APPROVED *Matthew R Rauch*
for State Traffic Engineer

DATE 5/21/19 PLATE NO. R3-8.1

PROJECT NO: _____ HWY: _____ COUNTY: _____ SHEET NO: **E**

7

7

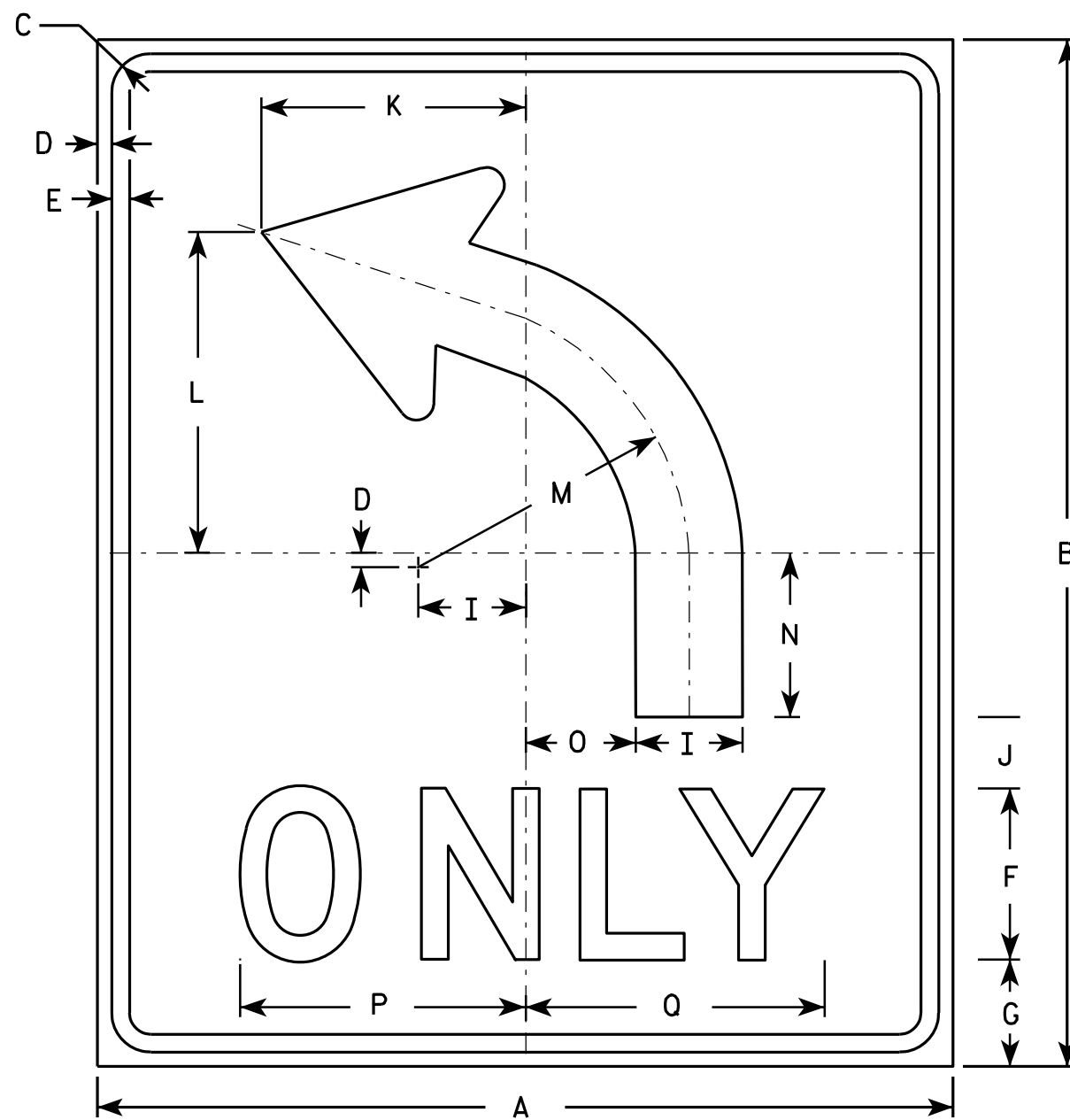

R3-50L

NOTES

1. Sign is Type II - Type H Reflective - reference WIS DOT Standard Specification for HIGHWAY and STRUCTURE CONSTRUCTION latest edition.
2. Color:
Background - White
Message - Black
3. Message Series - D
4. Corners may be square or rounded when base material is plywood but borders shall be rounded as shown. When base material is metal, the corners and borders shall be rounded.
5. R3-50R is the same as R3-50L except curved portion of arrow points right.

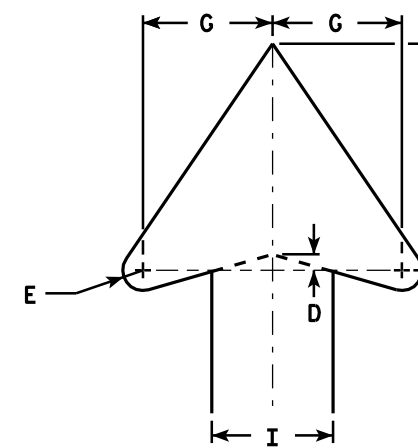

ARROW DETAIL

7

7

SIZE	A	B	C	D	E	F	G	H	I	J	K	L	M	N	O	P	Q	R	S	T	U	V	W	X	Y	Z	Area sq. ft.
1																											
2S	30	36	1 3/8	1/2	5/8	6	4	7	3 3/4	2 1/2	9 1/4	11 1/4	9 1/2	5 3/4	3 7/8	10	10 1/2										7.5
2M	30	36	1 3/8	1/2	5/8	6	4	7	3 3/4	2 1/2	9 1/4	11 1/4	9 1/2	5 3/4	3 7/8	10	10 1/2										7.5
3																											
4																											
5																											

STANDARD SIGN
R3-50

WISCONSIN DEPT OF TRANSPORTATION

APPROVED *Matthew R. Raush*
for State Traffic Engineer

DATE 3/24/2011 PLATE NO. R3-50.2

PROJECT NO: _____ HWY: _____ COUNTY: _____ SHEET NO: _____ E

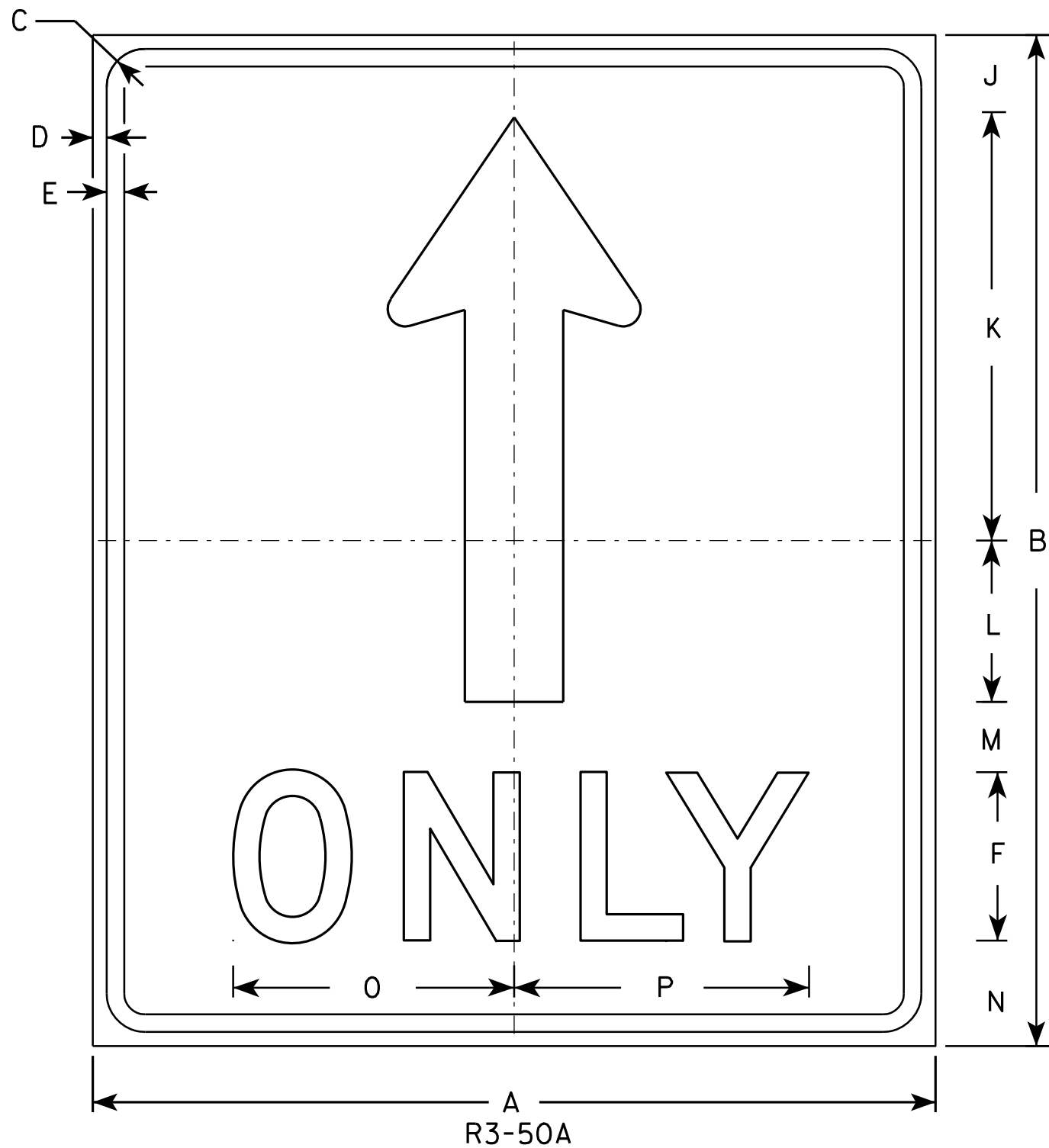

NOTES

1. Sign is Type II - Type H Reflective - reference WIS DOT Standard Specification for HIGHWAY and STRUCTURE CONSTRUCTION latest edition.
2. Color:
Background - White
Message - Black
3. Message Series - D
4. Corners may be square or rounded when base material is plywood but borders shall be rounded as shown. When base material is metal, the corners and borders shall be rounded.

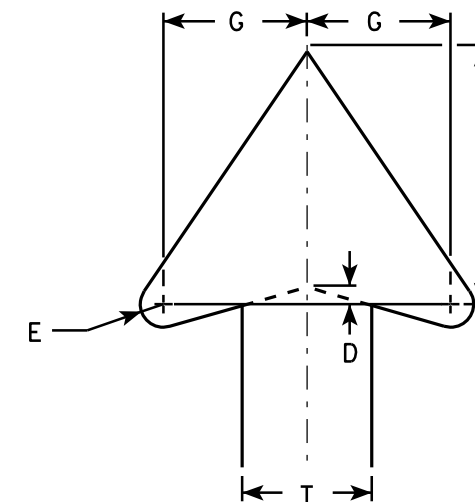

ARROW DETAIL

SIZE	A	B	C	D	E	F	G	H	I	J	K	L	M	N	O	P	Q	R	S	T	U	V	W	X	Y	Z	Area sq. ft.
1																											
2S	30	36	1 3/8	1/2	5/8	6	4	7	3 1/2	2 3/4	15 1/4	5 3/4	2 1/2	3 3/4	10	10 1/2										7.5	
2M	30	36	1 3/8	1/2	5/8	6	4	7	3 1/2	2 3/4	15 1/4	5 3/4	2 1/2	3 3/4	10	10 1/2										7.5	
3																											
4																											
5																											

STANDARD SIGN
R3-50A

WISCONSIN DEPT OF TRANSPORTATION

APPROVED *Matthew R. Rauch*
for State Traffic Engineer

DATE 3/24/2011 PLATE NO. R3-50A.3

PROJECT NO: _____ HWY: _____ COUNTY: _____ SHEET NO: **E**

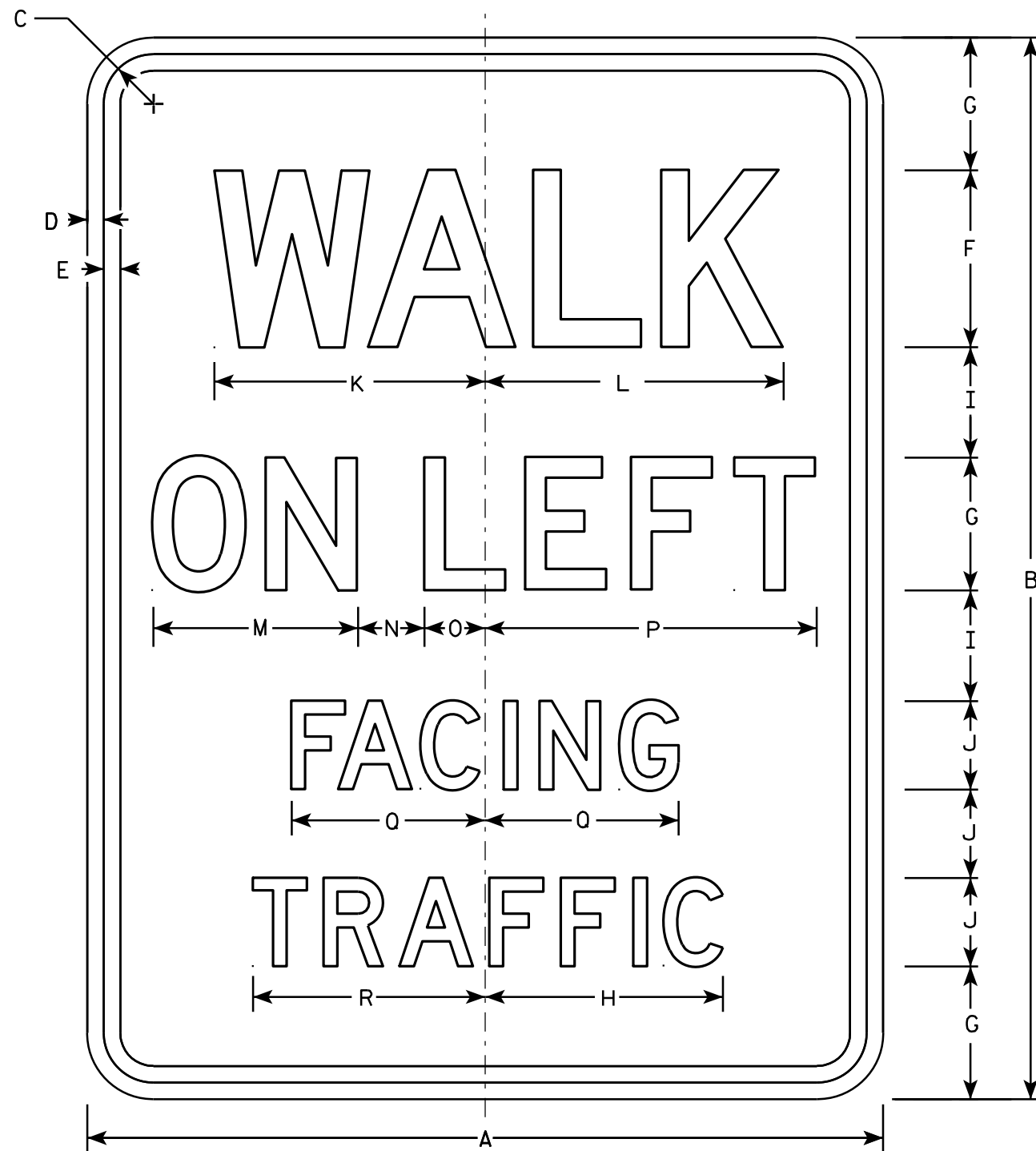

NOTES

1. Sign is Type II - Type H Reflective - reference WIS DOT Standard Specification for HIGHWAY and STRUCTURE CONSTRUCTION latest edition.
2. Color:
Background - White
Message - Black
3. Message Series - D
4. Corners may be square or rounded when base material is plywood but borders shall be rounded as shown. When base material is metal, the corners and borders shall be rounded.

7

7

R9-1

SIZE	A	B	C	D	E	F	G	H	I	J	K	L	M	N	O	P	Q	R	S	T	U	V	W	X	Y	Z	Area sq. ft.
1	18	24	1 1/8	3/8	1/2	4	3	5 3/8	2 1/2	2	6 1/8	6 3/4	4 5/8	1 1/2	1 3/8	7 1/2	4 3/8	5 1/4									3.0
2S	18	24	1 1/8	3/8	1/2	4	3	5 3/8	2 1/2	2	6 1/8	6 3/4	4 5/8	1 1/2	1 3/8	7 1/2	4 3/8	5 1/4									3.0
2M	18	24	1 1/8	3/8	1/2	4	3	5 3/8	2 1/2	2	6 1/8	6 3/4	4 5/8	1 1/2	1 3/8	7 1/2	4 3/8	5 1/4									3.0
3																											
4																											
5																											

STANDARD SIGN
R9-1

WISCONSIN DEPT OF TRANSPORTATION
APPROVED *Matthew R. Rauch*
for State Traffic Engineer

DATE 4/1/2011 PLATE NO. R9-1.5

PROJECT NO: _____ HWY: _____ COUNTY: _____ SHEET NO: _____ E

NOTES

1. Sign is Type II - Type F Reflective
2. Color:
Background - Yellow
Message - Black
3. W2-2L same as W2-2R but is rotated 180° when mounted.

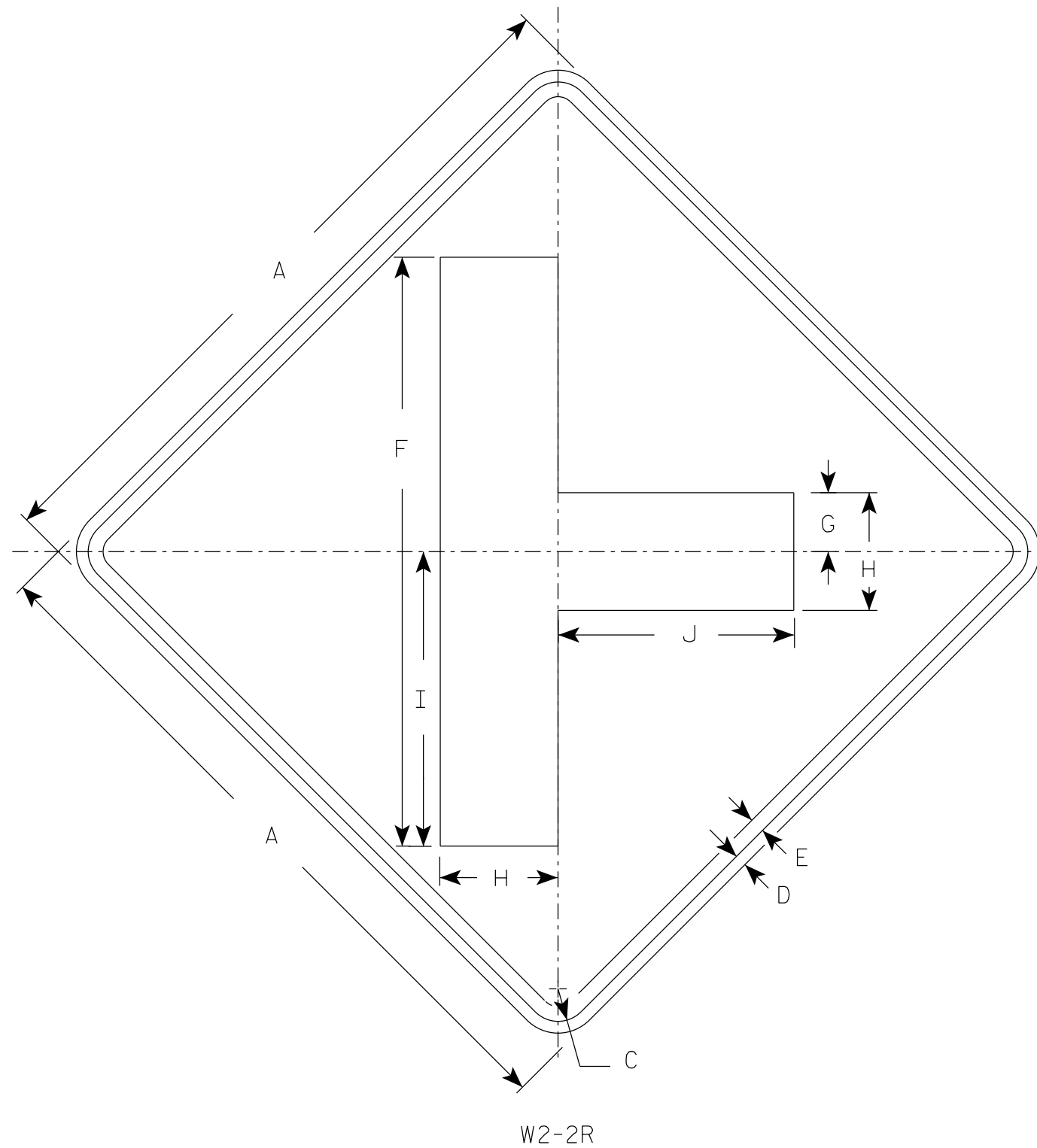

W2-2R

SIZE	A	B	C	D	E	F	G	H	I	J	K	L	M	N	O	P	Q	R	S	T	U	V	W	X	Y	Z	Area sq. ft.
1	24		1 1/8	3/8	1/2	20	2	4	10	8																	4.0
2S	30		1 3/8	1/2	5/8	25	2 1/2	5	12 1/2	10																	6.25
2M	30		1 3/8	1/2	5/8	25	2 1/2	5	12 1/2	10																	6.25
3	36		1 5/8	5/8	3/4	30	3	6	15	12																	9.0
4	48		2 1/4	3/4	1	40	4	8	20	16																	16.0
5																											

STANDARD SIGN
W2-2 L&R

WISCONSIN DEPT OF TRANSPORTATION
 APPROVED *Matthew R Rauch*
 for State Traffic Engineer
 DATE 11/18/2021 PLATE NO. W2-2.7

PROJECT NO: _____ HWY: _____ COUNTY: _____ SHEET NO: **E**

NOTES

1. Sign is Type II - Type F Reflective - reference WIS DOT Standard Specification for HIGHWAY and STRUCTURE CONSTRUCTION latest edition.
2. Color:
Background - Yellow
Message - Black
3. Corners may be square or rounded when base material is plywood but borders shall be rounded as shown. When base material is metal, the corners and borders shall be rounded.

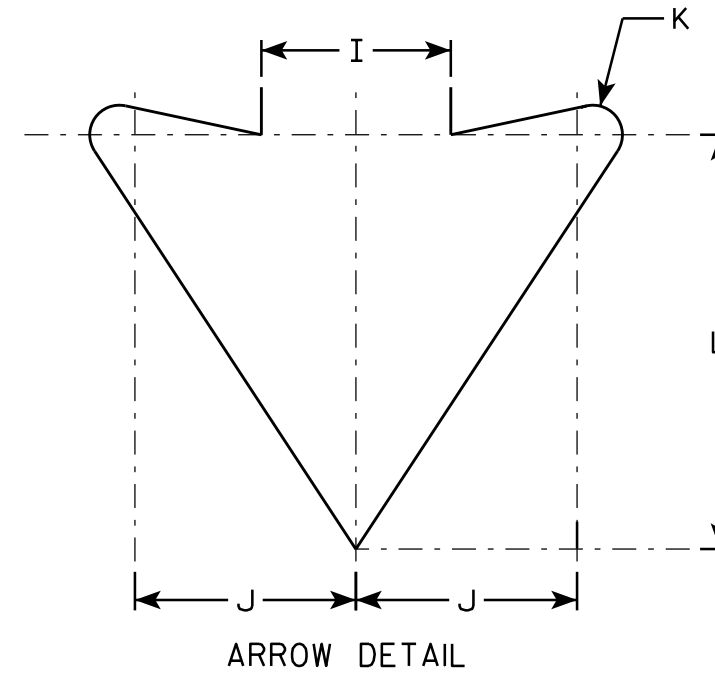
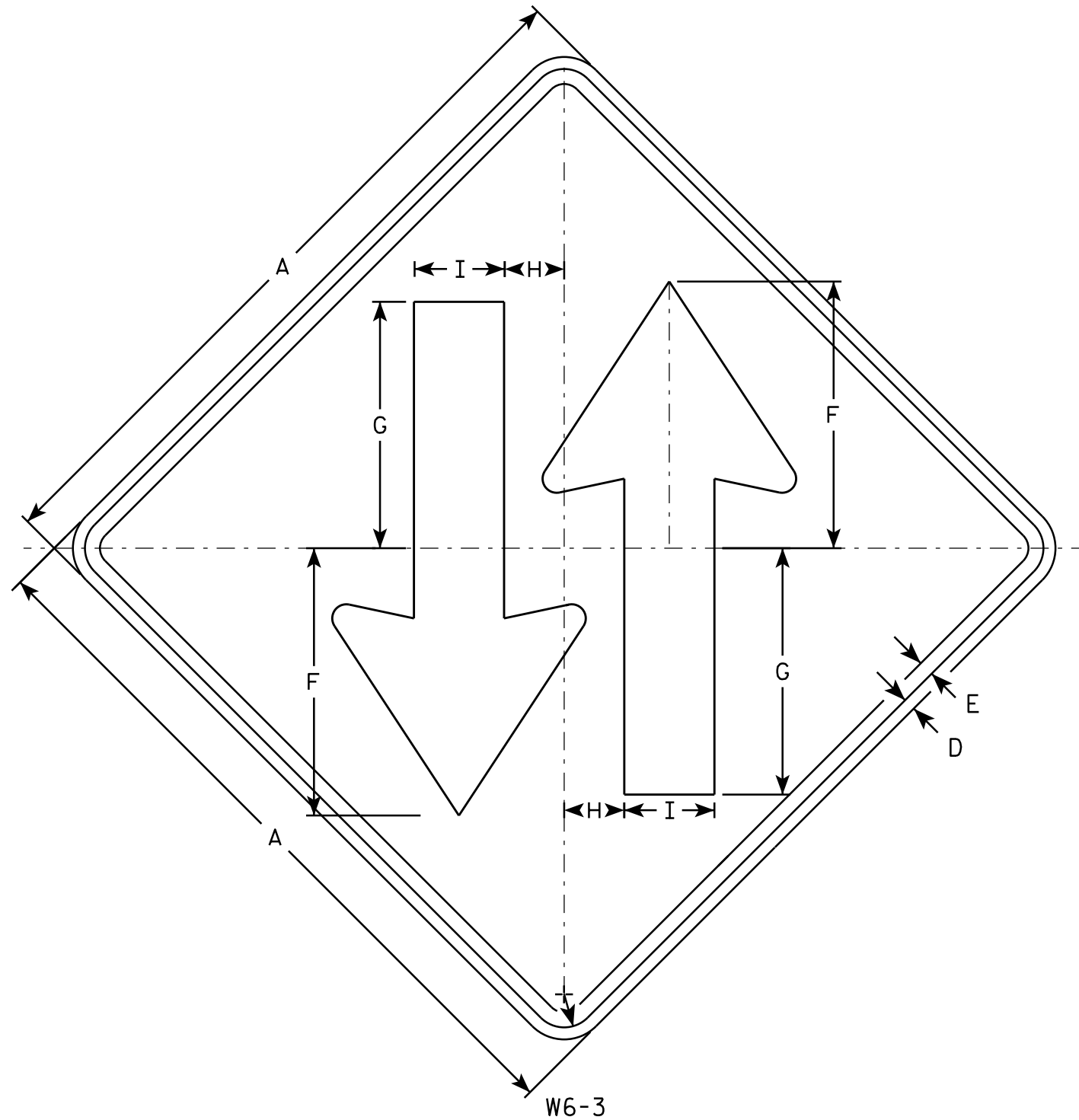

SIZE	A	B	C	D	E	F	G	H	I	J	K	L	M	N	O	P	Q	R	S	T	U	V	W	X	Y	Z	Area sq. ft.
1	30		1 3/8	1/2	5/8	11 1/8	10 1/4	2 1/2	3 3/4	4 3/8	5/8	8 1/4															6.25
2S	36		1 5/8	5/8	3/4	13 3/8	12 1/4	3	4 1/2	5 1/4	3/4	9 7/8															9.0
2M	36		1 5/8	5/8	3/4	13 3/8	12 1/4	3	4 1/2	5 1/4	3/4	9 7/8															9.0
3																											
4	48		2 1/4	3/4	1	17 3/4	16 3/8	4	6	7	1	13 1/8															16.0
5	48		2 1/4	3/4	1	17 3/4	16 3/8	4	6	7	1	13 1/8															16.0

STANDARD SIGN
W6-3

WISCONSIN DEPT OF TRANSPORTATION

APPROVED *Matthew R. Rauch*
For State Traffic Engineer

DATE 3/10/16 PLATE NO. W6-3.11

LEFT

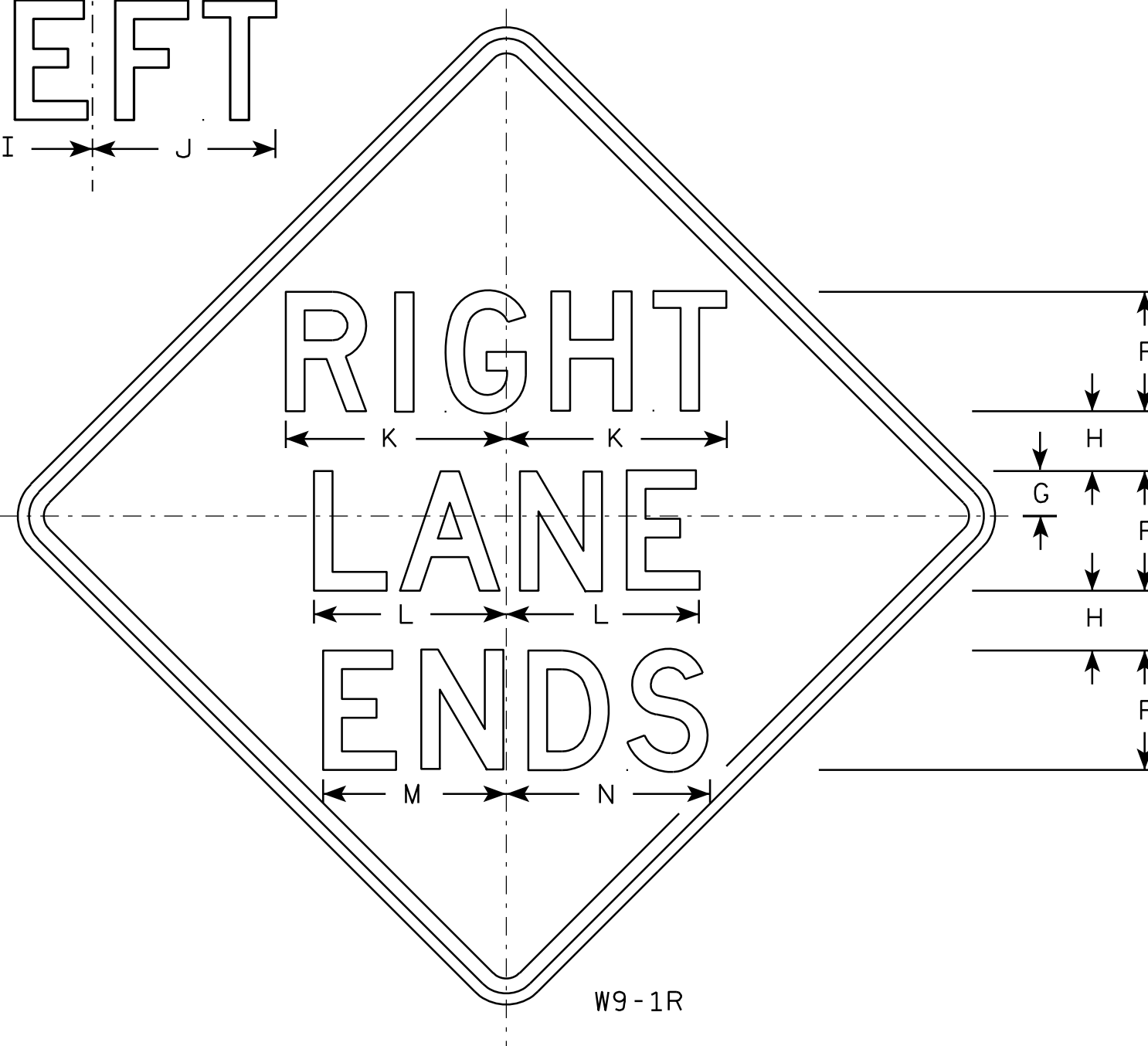

W9-1R

NOTES

1. Sign is Type II - Type F Reflective - reference WIS DOT Standard Specification for HIGHWAY and STRUCTURE CONSTRUCTION latest edition.
2. Color:
Background - Yellow
Message - Black
3. Message Series - D
4. Corners may be square or rounded when base material is plywood but borders shall be rounded as shown. When base material is metal, the corners and borders shall be rounded.
5. W9-1L same as W9-1R except the word Left replaces Right.

7

7

SIZE	A	B	C	D	E	F	G	H	I	J	K	L	M	N	O	P	Q	R	S	T	U	V	W	X	Y	Z	Area sq. ft.
1	30		1 3/8	1/2	5/8	5	1 1/2	2 1/2	7 1/8	7 5/8	9 1/4	8 1/8	7 5/8	8 5/8													6.25
2S	36		1 5/8	5/8	3/4	6	2	3	8 1/2	9 1/8	11	9 3/4	9	10 3/8													9.0
2M	36		1 5/8	5/8	3/4	6	2	3	8 1/2	9 1/8	11	9 3/4	9	10 3/8													9.0
3	36		1 5/8	5/8	3/4	6	2	3	8 1/2	9 1/8	11	9 3/4	9	10 3/8													9.0
4	36		1 5/8	5/8	3/4	6	2	3	8 1/2	9 1/8	11	9 3/4	9	10 3/8													9.0
5	48		2 1/4	3/4	1	8	3	4	11 1/4	12 1/4	14 3/4	12 7/8	12 1/4	13 5/8													16.0

STANDARD SIGN
W9-1

WISCONSIN DEPT OF TRANSPORTATION

APPROVED *Matthew R. Rauch*
for State Traffic Engineer

DATE 03/18/13 PLATE NO. W9-1.8

PROJECT NO:

SHEET NO:

E

NOTES

1. Sign is Type II - Type F Reflective
2. Color:
 Background - Yellow
 Message - Black

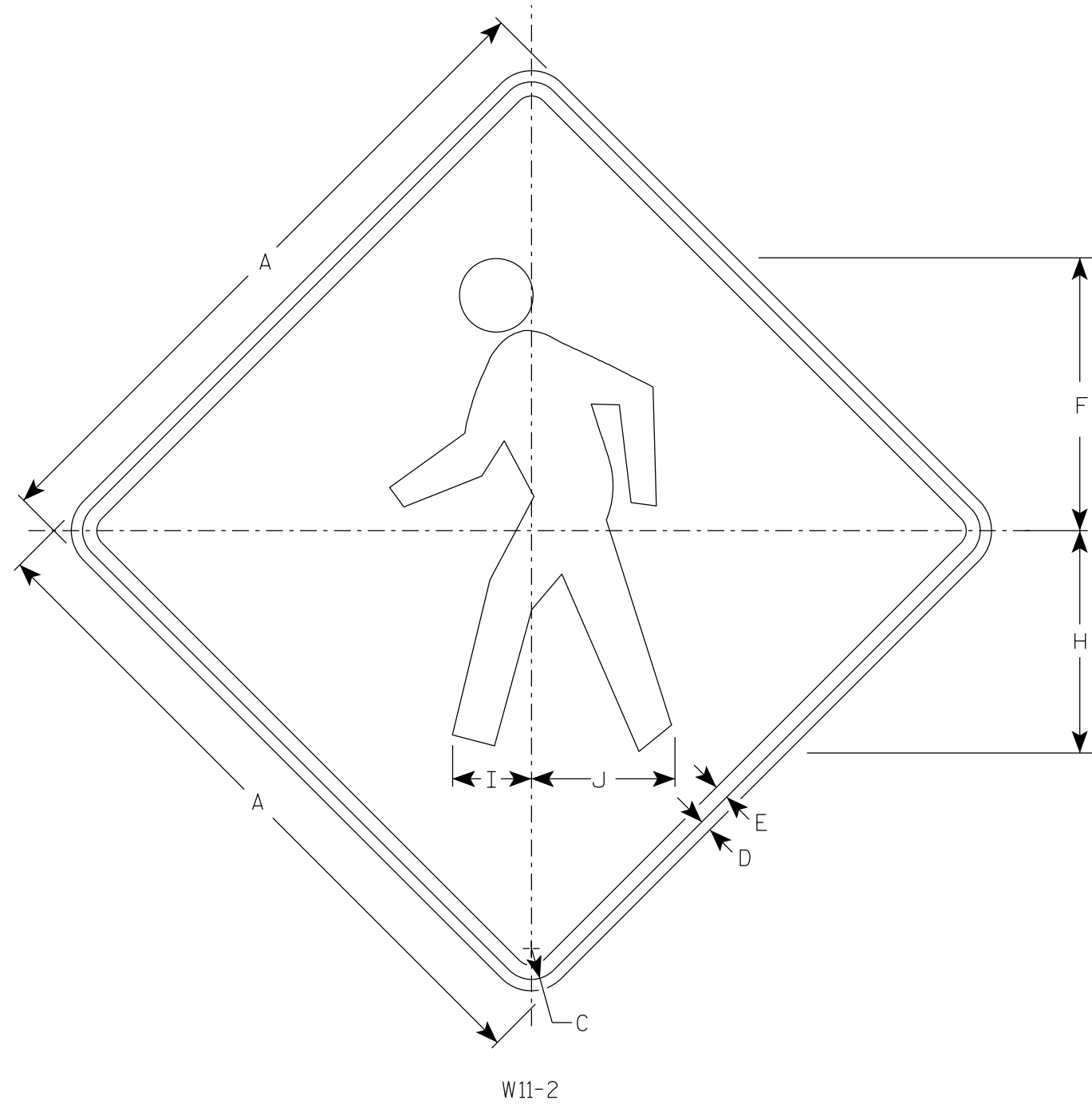

W11-2

SIZE	A	B	C	D	E	F	G	H	I	J	K	L	M	N	O	P	Q	R	S	T	U	V	W	X	Y	Z	Area sq. ft.
1	24		1 1/8	3/8	1/2	9 3/4		7 7/8	2 7/8	5 1/8																	4.0
2S	30		1 3/8	1/2	5/8	12 1/8		9 7/8	3 1/2	6 3/8																	6.25
2M	36		1 5/8	5/8	3/4	14 1/2		11 7/8	4 1/4	7 5/8																	9.0
3	36		1 5/8	5/8	3/4	14 1/2		11 7/8	4 1/4	7 5/8																	9.0
4	48		2 1/4	3/4	1	19 3/8		15 3/4	5 5/8	10 1/4																	16.0
5																											

STANDARD SIGN
W11-2

WISCONSIN DEPT OF TRANSPORTATION

APPROVED *Matthew R Rauch*
for State Traffic Engineer

DATE 4/8/2020 PLATE NO. W11-2.8

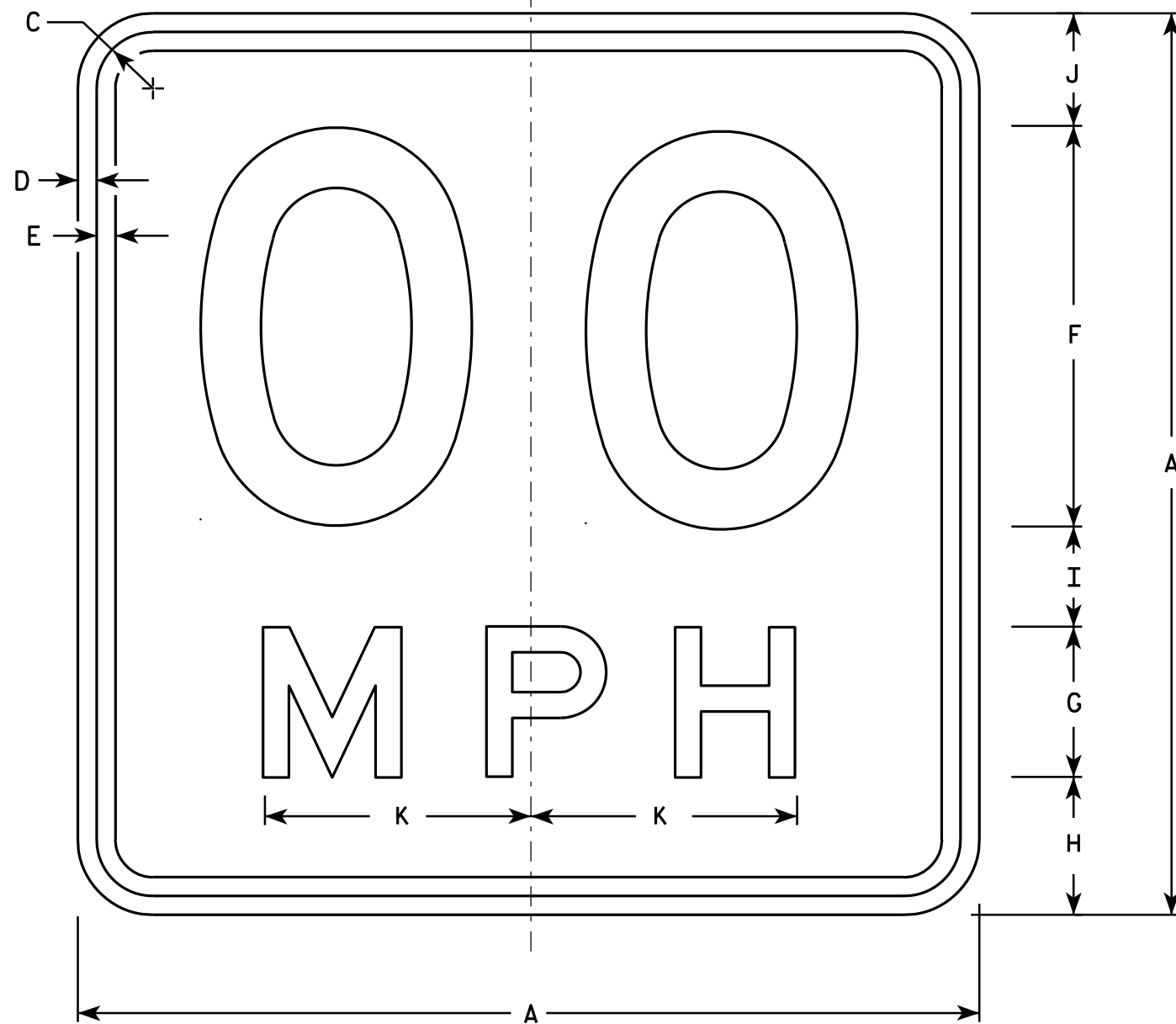

NOTES

1. Sign is Type II - Type F Reflective - reference WIS DOT Standard Specification for HIGHWAY and STRUCTURE CONSTRUCTION latest edition.
2. Color:
Background - Yellow
Message - Black
3. Message Series - See Note 6
4. Corners may be square or rounded when base material is plywood but borders shall be rounded as shown. When base material is metal, the corners and borders shall be rounded.
5. Substitute appropriate numerals and optically space about centerline to achieve proper balance.
6. Line 1 is Series D
Line 2 is Series E

W13-1

* For 30" x 30" Warning Signs, use 18" x 18" W13-1 signs.
For 36" x 36" Warning Signs, use 24" x 24" W13-1 signs.

SIZE	A	B	C	D	E	F	G	H	I	J	K	L	M	N	O	P	Q	R	S	T	U	V	W	X	Y	Z	Area sq. ft.
1	18		1 1/8	3/8	3/8	8	3	2 3/4	2	2 1/4	5 3/8																2.25
* 2S	18		1 1/8	3/8	3/8	8	3	2 3/4	2	2 1/4	5 3/8																2.25
* 2M	18		1 1/8	3/8	3/8	8	3	2 3/4	2	2 1/4	5 3/8																2.25
3	24		1 1/8	3/8	1/2	10	4	4	2 3/4	3 1/4	6 5/8																4.00
4	36		1 5/8	5/8	3/4	16	6	5 1/2	4	4 1/2	10 5/8																9.00
5	36		1 5/8	5/8	3/4	16	6	5 1/2	4	4 1/2	10 5/8																9.00

STANDARD SIGN
W13-1

WISCONSIN DEPT OF TRANSPORTATION

APPROVED *Matthew R. Rauch*
For State Traffic Engineer

DATE 5/31/12 PLATE NO. W13-1.16

PROJECT NO:

HWY:

COUNTY:

SHEET NO:

E

NOTES

1. Sign is Type II - Type F Reflective
2. Color:
Background - Yellow
Message - Black
3. Message Series - C



W16-9P

SIZE	A	B	C	D	E	F	G	H	I	J	K	L	M	N	O	P	Q	R	S	T	U	V	W	X	Y	Z	Area sq. ft.
1																											
2S	24	12	1 1/8	3/8	3/8	5	3 1/2	3 1/8	17 3/4																		2.0
2M	30	18	1 1/8	3/8	1/2	7	5 1/2	2 3/4	24 1/2																		3.75
3	30	18	1 1/8	3/8	1/2	7	3 1/2	2 3/4	24 1/2																		3.75
4	48	24	1 3/8	1/2	5/8	10	7	6 1/8	35 3/4																		8.0
5																											

STANDARD SIGN
W16-9P

WISCONSIN DEPT OF TRANSPORTATION

APPROVED Matthew R. Rauch
State Traffic Engineer

DATE 3/7/19 PLATE NO. W16-9P.7

PROJECT NO: _____ HWY: _____ COUNTY: _____ SHEET NO: **E**

7

7

STATION	REAL STATION	DISTANCE	AREA (SF)				ELEMENTAL VOL (CY) (UNADJUS			CUMULATIVE VOL (CY)					
			CUT	SALVAGED/UNUSABLE PAVEMENT MATERIAL	FILL	MARSH EXC	CUT	FILL	MARSH EXC	CUT	EXPANDED FILL	EXPANDED MARSH BACKFILL	REDUCED MARSH IN FILL	MASS ORDNATE	
															NOTE 1
541+77	54177.00	0.00	0.00	0.00	0.00	0.00	0	0	0	0	0	0	0	0	0
542+00	54200.00	23.00	32.77	0.00	1.58	0.00	14	1	0	14	1	0	0	0	13
542+50	54250.00	50.00	41.34	0.00	1.27	0.00	69	3	0	83	6	0	0	0	77
543+00	54300.00	50.00	42.35	0.00	4.92	0.00	77	6	0	160	14	0	0	0	146
543+50	54350.00	50.00	37.57	0.00	15.92	0.00	74	19	0	234	41	0	0	0	193
544+00	54400.00	50.00	36.64	0.00	20.41	0.00	69	34	0	303	89	0	0	0	214
544+50	54450.00	50.00	37.72	0.00	13.28	0.00	69	31	0	372	133	0	0	0	239
545+00	54500.00	50.00	42.69	0.00	5.36	0.00	74	17	0	446	158	0	0	0	288
545+50	54550.00	50.00	37.57	0.00	8.15	0.00	74	13	0	520	176	0	0	0	344
546+00	54600.00	50.00	37.47	0.00	13.67	0.00	69	20	0	589	204	0	0	0	385
546+50	54650.00	50.00	17.83	0.00	23.99	15.82	51	35	15	640	244	23	8	0	396
547+00	54700.00	50.00	-23.17	0.00	35.85	58.04	-5	55	68	635	273	125	42	0	362
547+50	54750.00	50.00	39.41	0.00	30.05	0.00	15	61	54	650	322	206	69	0	328
548+00	54800.00	50.00	37.57	0.00	31.21	0.00	71	57	0	721	403	206	69	0	318
548+50	54850.00	50.00	44.06	0.00	20.24	0.00	76	48	0	797	471	206	69	0	326
549+00	54900.00	50.00	53.80	0.00	11.28	0.00	91	29	0	888	512	206	69	0	376
549+50	54950.00	50.00	52.50	0.00	2.39	10.98	98	13	10	986	523	221	74	0	463
550+00	55000.00	50.00	47.68	0.00	0.00	11.56	93	2	21	1,079	511	252	84	0	568
550+50	55050.00	50.00	33.91	0.00	0.09	16.40	76	0	26	1,155	493	291	97	0	662
551+00	55100.00	50.00	28.79	0.00	0.00	23.05	58	0	37	1,213	466	347	116	0	747
551+50	55150.00	50.00	41.99	0.00	0.00	13.11	66	0	33	1,279	443	396	132	0	836
552+00	55200.00	50.00	59.45	0.00	0.00	0.99	94	0	13	1,373	434	416	139	0	939
552+50	55250.00	50.00	58.85	0.00	0.00	7.70	110	0	8	1,483	428	428	143	0	1,055
553+00	55300.00	50.00	60.80	0.00	0.00	7.00	111	0	14	1,594	418	449	150	0	1,176
553+50	55350.00	50.00	54.13	0.00	0.04	11.60	106	0	17	1,700	406	474	158	0	1,294
554+00	55400.00	50.00	45.11	0.00	0.36	15.03	92	0	25	1,792	388	512	171	0	1,404
554+50	55450.00	50.00	49.38	0.00	2.10	8.89	87	2	22	1,879	376	545	182	0	1,503
555+00	55500.00	50.00	48.35	0.00	1.55	12.33	90	3	20	1,969	366	575	192	0	1,603
555+50	55550.00	50.00	50.08	0.00	3.10	10.78	91	4	21	2,060	356	606	202	0	1,704
556+00	55600.00	50.00	46.29	0.00	3.53	13.97	89	6	23	2,149	349	641	214	0	1,800
556+50	55650.00	50.00	54.32	0.00	1.85	6.00	93	5	18	2,242	343	668	223	0	1,899
557+00	55700.00	50.00	46.30	0.00	3.47	15.96	93	5	20	2,335	336	698	233	0	1,999
557+50	55750.00	50.00	46.14	0.00	2.92	15.53	86	6	29	2,421	324	741	247	0	2,097
558+00	55800.00	50.00	46.84	0.00	3.43	11.00	86	6	25	2,507	315	779	260	0	2,192
558+50	55850.00	50.00	74.88	0.00	0.00	0.00	113	3	10	2,620	312	794	265	0	2,308
559+00	55900.00	50.00	55.97	0.00	0.81	8.01	121	1	7	2,741	308	804	268	0	2,433
559+50	55950.00	50.00	54.57	0.00	1.20	9.00	102	2	16	2,843	300	828	276	0	2,543
560+00	56000.00	50.00	53.56	0.00	1.77	9.98	100	3	18	2,943	291	855	285	0	2,652
560+50	56050.00	50.00	53.95	0.00	2.01	8.57	100	3	17	3,043	283	881	294	0	2,760
561+00	56100.00	50.00	53.40	0.00	3.63	5.25	99	5	13	3,142	281	900	300	0	2,861
561+50	56150.00	50.00	50.71	0.00	3.51	9.00	96	7	13	3,238	282	920	307	0	2,956
562+00	56200.00	50.00	53.53	0.00	2.16	10.96	97	5	18	3,335	276	947	316	0	3,059
562+50	56250.00	50.00	54.90	0.00	4.15	8.00	100	6	18	3,435	272	974	325	0	3,163
563+00	56300.00	50.00	48.65	0.00	6.44	10.29	96	10	17	3,531	274	999	333	0	3,257
563+50	56350.00	50.00	47.73	0.00	7.04	11.22	89	12	20	3,620	277	1,029	343	0	3,343
564+00	56400.00	50.00	58.24	0.00	7.15	0.00	98	13	10	3,718	288	1,044	348	0	3,430

STATION	REAL STATION	DISTANCE	AREA (SF)			EMENTAL VOL (CY) (UNADJUS			CUMULATIVE VOL (CY)						
			CUT	FILL	MARSH EXC	CUT	FILL	MARSH EXC	CUT	EXPANDED FILL	EXPANDED MARSH	BACKFILL	REDUCED MARSH IN FILL		MASS ORDINATE
													1.00	1.42	
						NOTE 1	NOTE 3	NOTE 1		NOTE 4		NOTE 6	NOTE 8		
564+50	56450	50	52.40	11.44	0	102	17	0	3820	312		1044	348	3508	
565+00	56500	50	52.96	44.18	0	98	51	0	3918	385		1044	348	3533	
565+50	56550	50	63.09	7.45	0	107	48	0	4025	453		1044	348	3572	
566+00	56600	50	77.99	0.00	0	131	7	0	4156	463		1044	348	3693	
566+50	56650	50	59.82	7.57	0	128	7	0	4284	473		1044	348	3811	
567+00	56700	50	56.85	7.26	6	108	14	6	4392	488		1053	351	3904	
567+50	56750	50	49.27	4.74	16	98	11	20	4490	490		1083	361	4000	
568+00	56800	50	84.01	0.00	0	123	4	15	4613	485		1106	369	4128	
568+50	56850	50	57.25	13.98	0	131	13	0	4744	503		1106	369	4241	
569+00	56900	50	57.16	3.94	0	106	17	0	4850	528		1106	369	4322	
569+50	56950	50	55.87	3.54	0	105	7	0	4955	537		1106	369	4418	
570+00	57000	50	27.51	5.18	23	77	8	21	5032	534		1137	379	4498	
570+50	57050	50	56.98	3.42	0	78	8	21	5110	530		1169	390	4580	
571+00	57100	50	28.69	9.59	17	79	12	16	5189	536		1193	398	4653	
571+50	57150	50	35.19	9.22	11	59	17	26	5248	542		1232	411	4706	
572+00	57200	50	19.99	16.95	13	51	24	22	5299	560		1265	422	4739	
572+50	57250	50	29.02	7.11	13	45	22	24	5344	574		1301	434	4770	
573+00	57300	50	39.30	11.16	0	63	17	12	5407	590		1319	440	4817	
573+50	57350	50	35.14	11.20	0	69	21	0	5476	620		1319	440	4856	
574+00	57400	50	39.17	5.63	0	69	16	0	5545	643		1319	440	4902	
574+50	57450	50	37.09	4.57	0	71	9	0	5616	655		1319	440	4961	
575+00	57500	50	39.85	0.50	0	71	5	0	5687	662		1319	440	5025	
575+50	57550	50	0.00	0.00	0	37	0	0	5724	662		1319	440	5062	
576+00	57600	50	0.00	0.00	0	0	0	0	5724	662		1319	440	5062	
576+50	57650	50	0.00	0.00	0	0	0	0	5724	662		1319	440	5062	
577+00	57700	50	0.00	0.00	0	0	0	0	5724	662		1319	440	5062	
577+50	57750	50	0.00	0.00	0	0	0	0	5724	662		1319	440	5062	
578+00	57800	50	0.00	0.00	0	0	0	0	5724	662		1319	440	5062	
578+50	57850	50	0.00	0.00	0	0	0	0	5724	662		1319	440	5062	
579+00	57900	50	0.00	0.00	0	0	0	0	5724	662		1319	440	5062	
579+50	57950	50	0.00	0.00	0	0	0	0	5724	662		1319	440	5062	
580+00	58000	50	0.00	0.00	0	0	0	0	5724	662		1319	440	5062	
580+50	58050	50	0.00	0.00	0	0	0	0	5724	662		1319	440	5062	
581+00	58100	50	0.00	0.00	0	0	0	0	5724	662		1319	440	5062	
581+50	58150	50	0.00	0.00	0	0	0	0	5724	662		1319	440	5062	
582+00	58200	50	0.00	0.00	0	0	0	0	5724	662		1319	440	5062	
582+50	58250	50	0.00	0.00	0	0	0	0	5724	662		1319	440	5062	
583+00	58300	50	0.00	0.00	0	0	0	0	5724	662		1319	440	5062	
583+50	58350	50	0.00	0.00	0	0	0	0	5724	662		1319	440	5062	
584+00	58400	50	0.00	0.00	0	0	0	0	5724	662		1319	440	5062	
584+50	58450	50	0.00	0.00	0	0	0	0	5724	662		1319	440	5062	
585+00	58500	50	0.00	0.00	0	0	0	0	5724	662		1319	440	5062	
585+50	58550	50	0.00	0.00	0	0	0	0	5724	662		1319	440	5062	
586+00	58600	50	0.00	0.00	0	0	0	0	5724	662		1319	440	5062	
586+50	58650	50	0.00	0.00	0	0	0	0	5724	662		1319	440	5062	
587+00	58700	50	0.00	0.00	0	0	0	0	5724	662		1319	440	5062	
587+50	58750	50	0.00	0.00	0	0	0	0	5724	662		1319	440	5062	
588+00	58800	50	0.00	0.00	0	0	0	0	5724	662		1319	440	5062	
588+50	58850	50	0.00	0.00	0	0	0	0	5724	662		1319	440	5062	
589+00	58900	50	0.00	0.00	0	0	0	0	5724	662		1319	440	5062	
589+17	58917	17	0.00	0.00	0	0	0	0	5724	662		1319	440	5062	

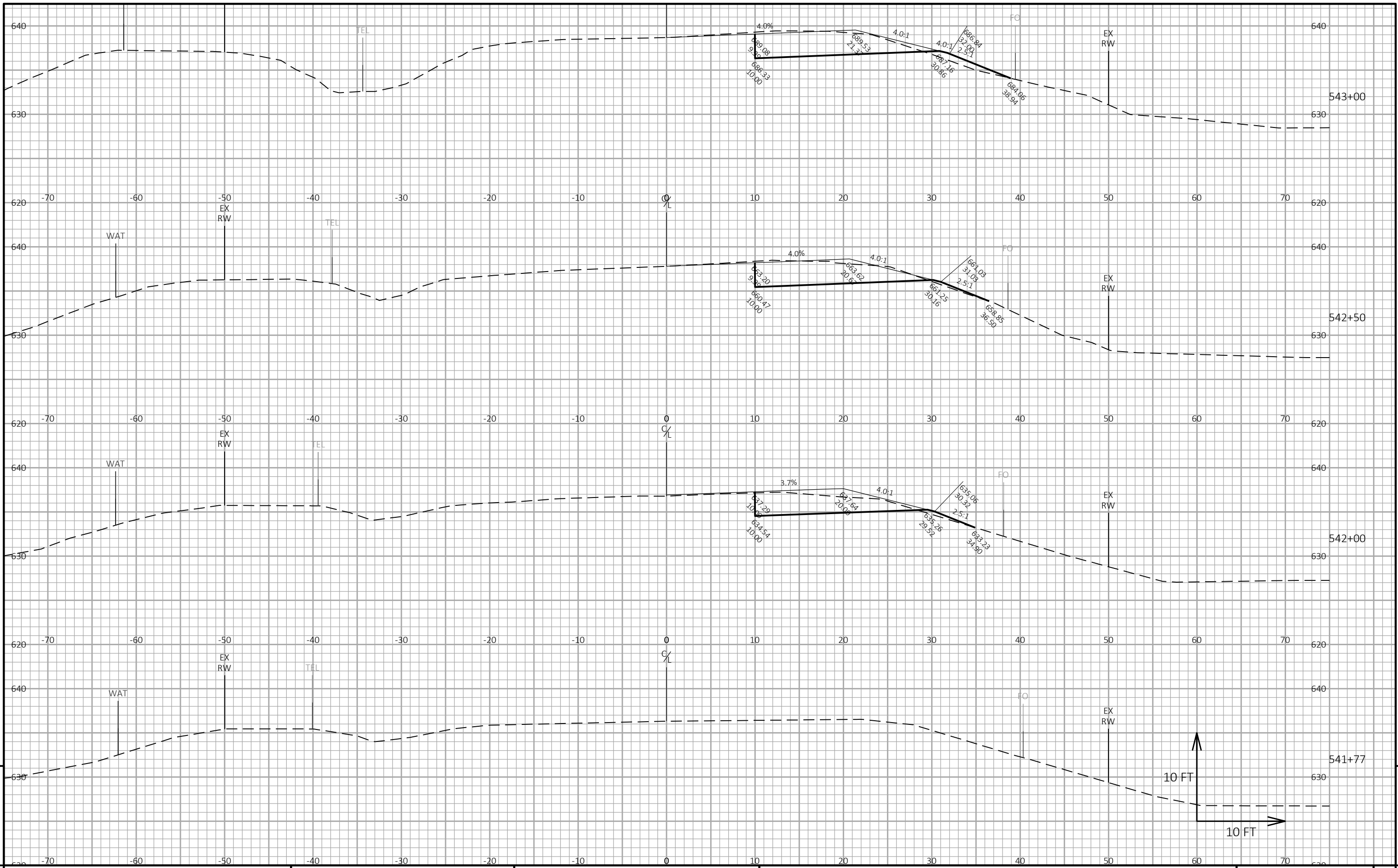

9

9

PROJECT NO: 1180-44-70 HWY: USH 2 COUNTY: ASHLAND & IRON CROSS SECTIONS: CROSS SECTIONS SHEET E

FILE NAME: N:\PDS\C3D\11804401\SHEETSPLAN\1180_44_01_XS.DWG PLOT DATE: 7/31/2022 9:02 PM PLOT BY: FINNEGAN, MITCHELL PLOT NAME: PLOT SCALE: 1 IN:10 FT HORZ. / 1 IN:10 FT VERT. WISDOT/CADD SHEET 49

LAYOUT NAME - 1

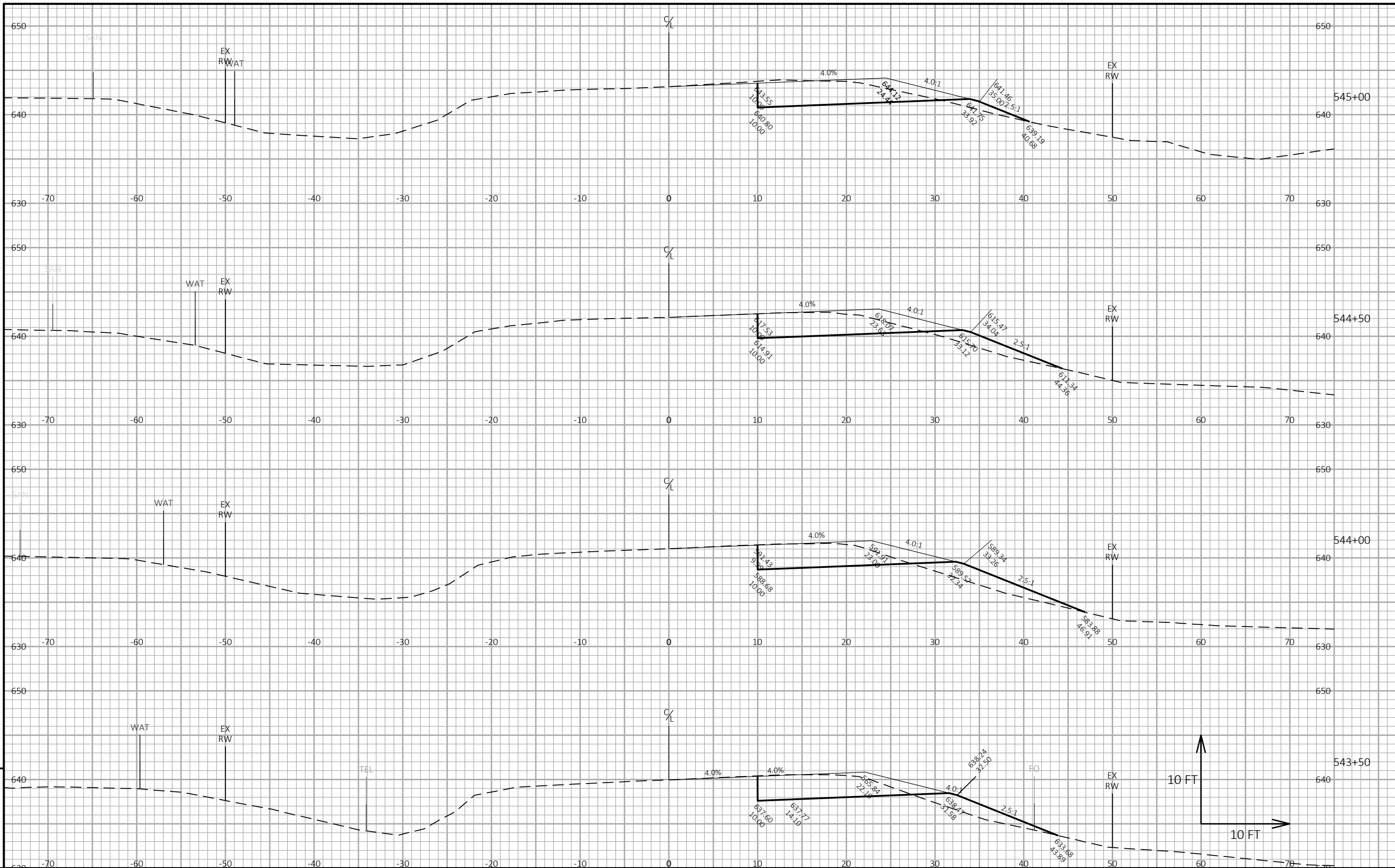

PROJECT NO: 1180-44-70

HWY: USH 2

COUNTY: ASHLAND & IRON

CROSS SECTIONS: CROSS SECTIONS

SHEET

E

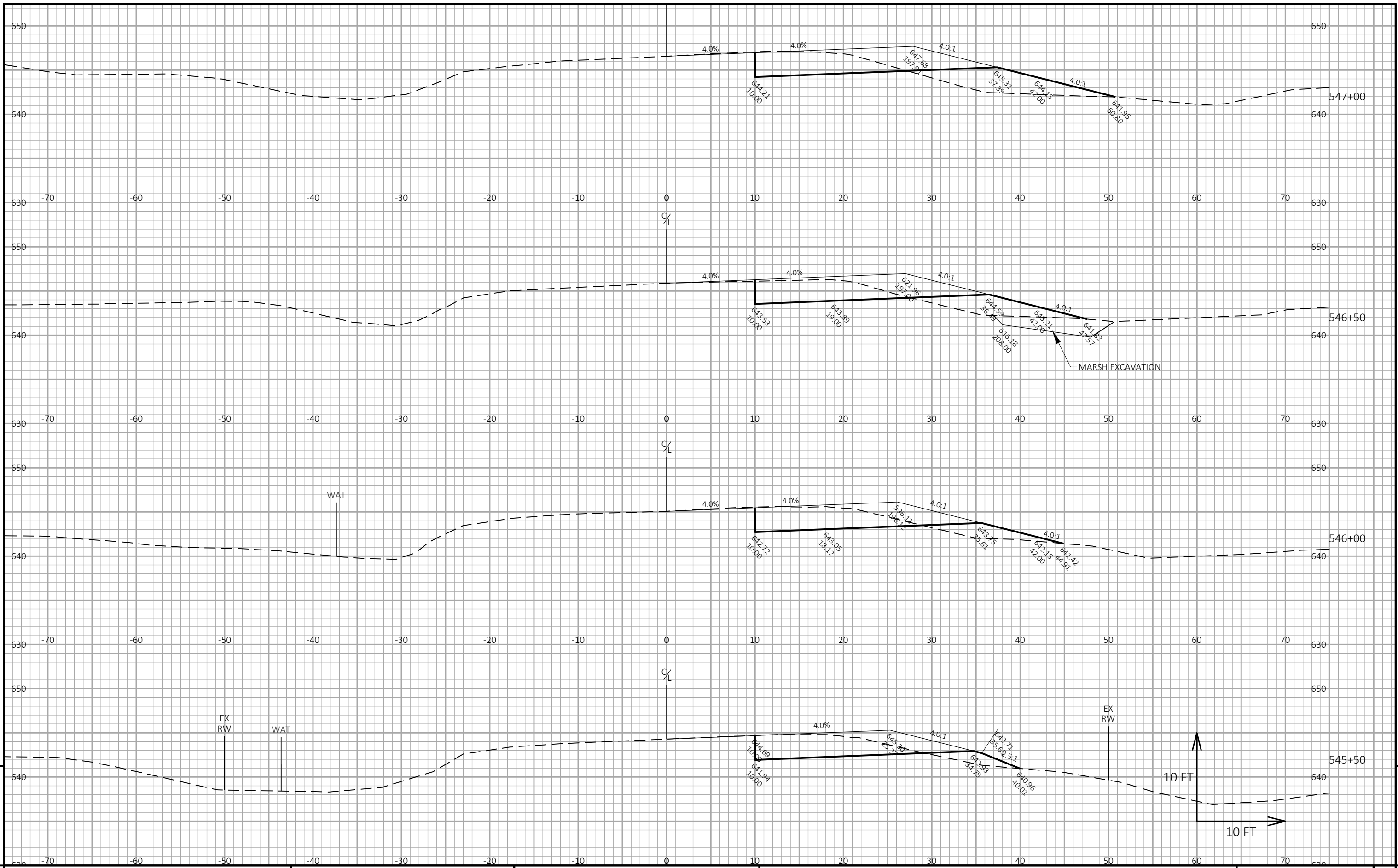

9

9

PROJECT NO: 1180-44-70	HWY: USH 2	COUNTY: ASHLAND & IRON	CROSS SECTIONS: CROSS SECTIONS	SHEET	E
------------------------	------------	------------------------	--------------------------------	-------	---

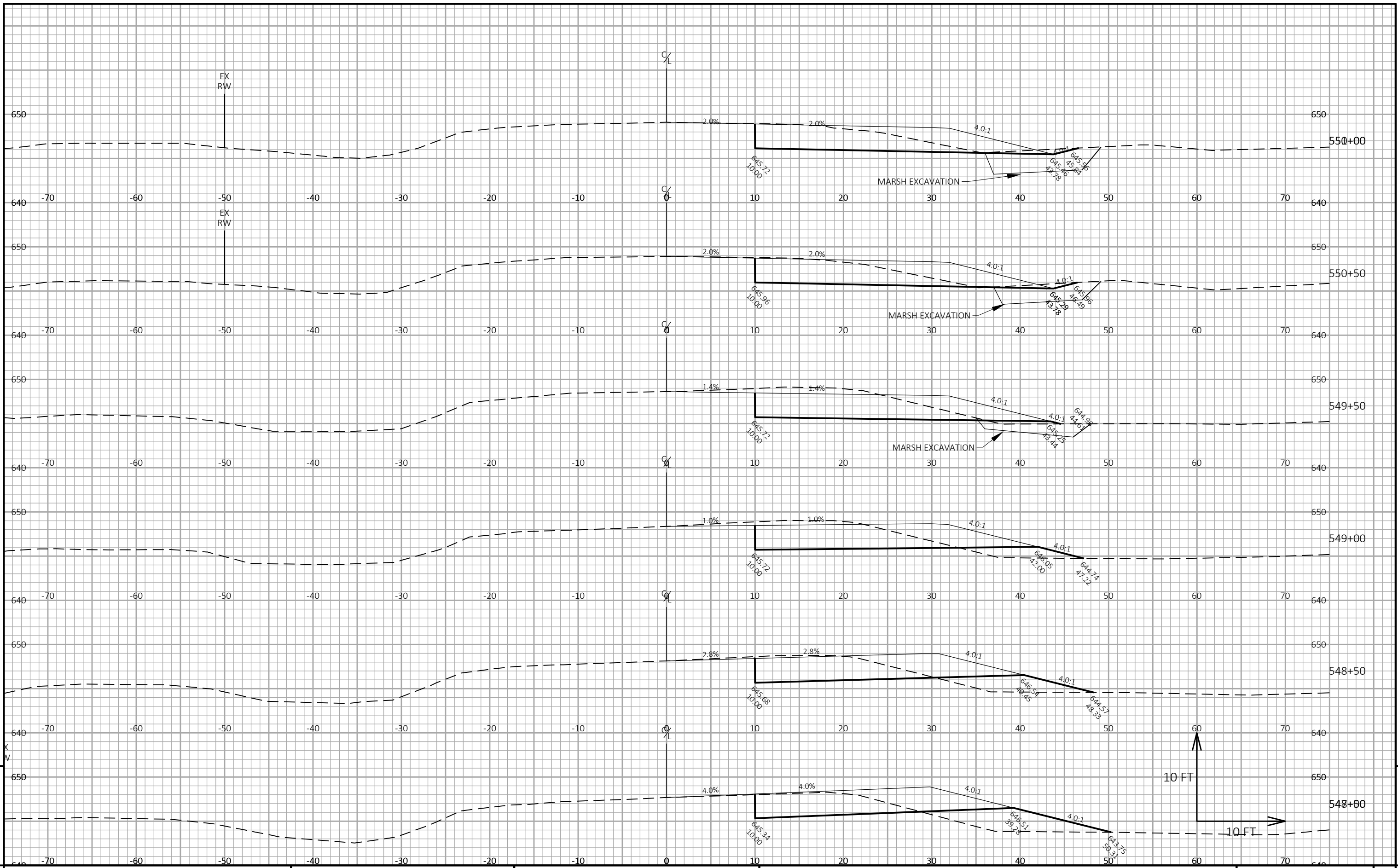

PROJECT NO: 1180-44-70

HWY: USH 2

COUNTY: ASHLAND & IRON

CROSS SECTIONS: CROSS SECTIONS

SHEET

E

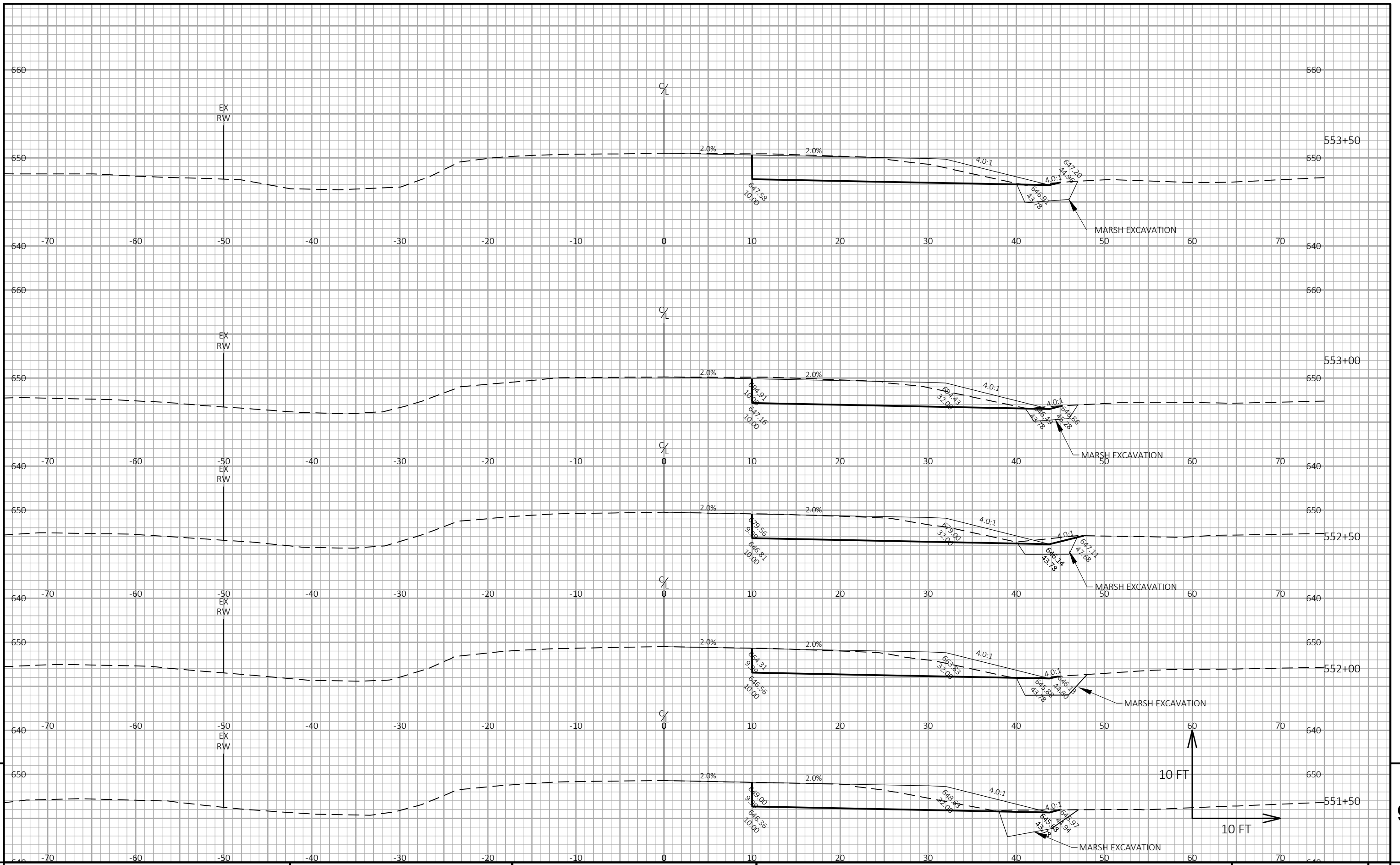

9

9

PROJECT NO: 1180-44-70	HWY: USH 2	COUNTY: ASHLAND & IRON	CROSS SECTIONS: CROSS SECTIONS	SHEET	E
------------------------	------------	------------------------	--------------------------------	-------	---

FILE NAME : N:\PDS\C3D\11804401\SHEETSPLAN\1180_44_01_XS.DWG PLOT DATE : 7/31/2022 9:02 PM PLOT BY : FINNEGAN, MITCHELL PLOT NAME : PLOT SCALE : 1 IN:10 FT HORZ. / 1 IN:10 FT VERT. WISDOT/CADD SHEET 49

LAYOUT NAME - 5

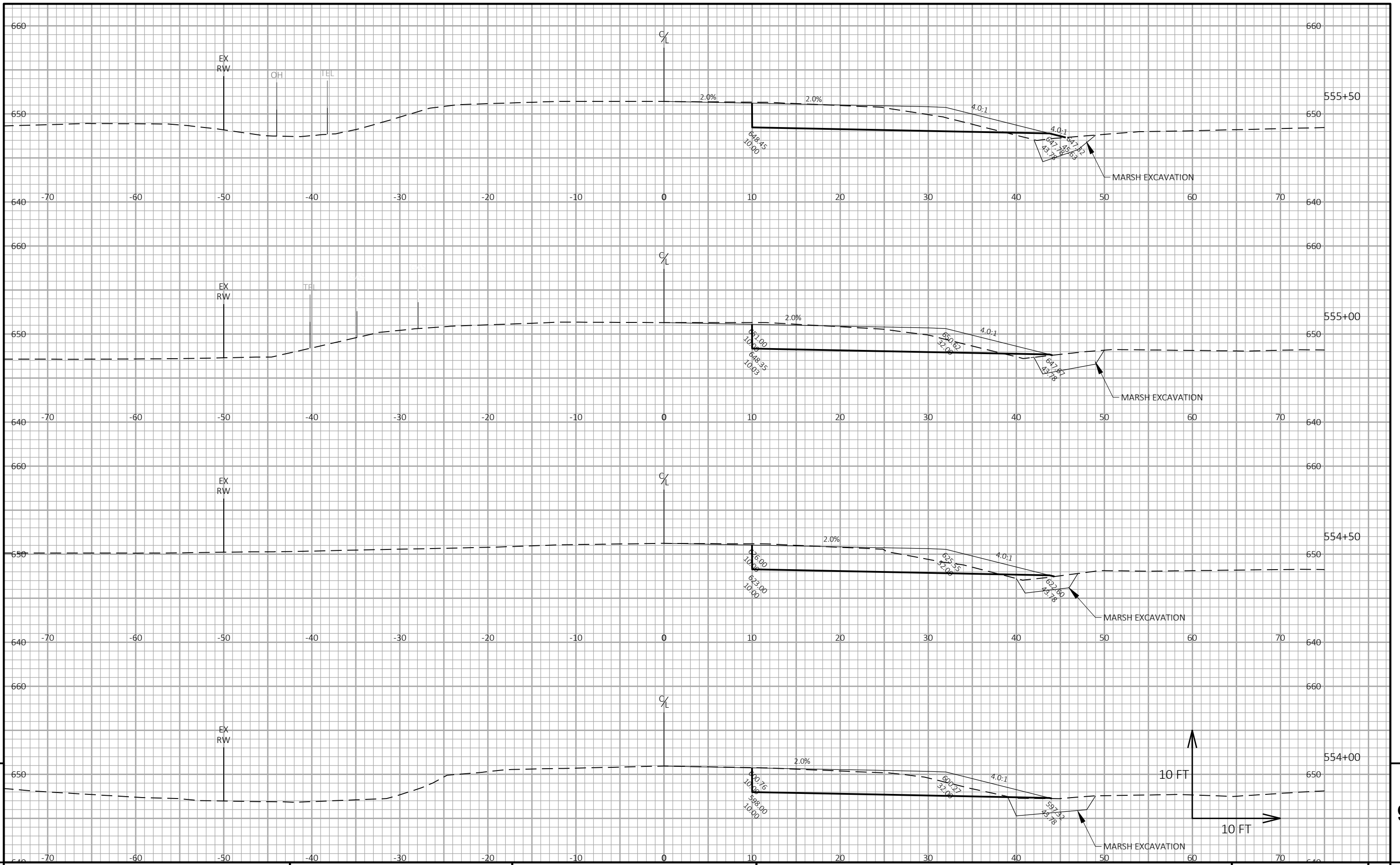

9

9

PROJECT NO: 1180-44-70 HWY: USH 2 COUNTY: ASHLAND & IRON CROSS SECTIONS: CROSS SECTIONS SHEET E

FILE NAME: N:\PDS\C3D\11804401\SHEETSPLAN\1180_44_01_XS.DWG PLOT DATE: 7/31/2022 9:02 PM PLOT BY: FINNEGAN, MITCHELL PLOT NAME: PLOT SCALE: 1 IN:10 FT HORZ. / 1 IN:10 FT VERT. WISDOT/CADD SHEET 49

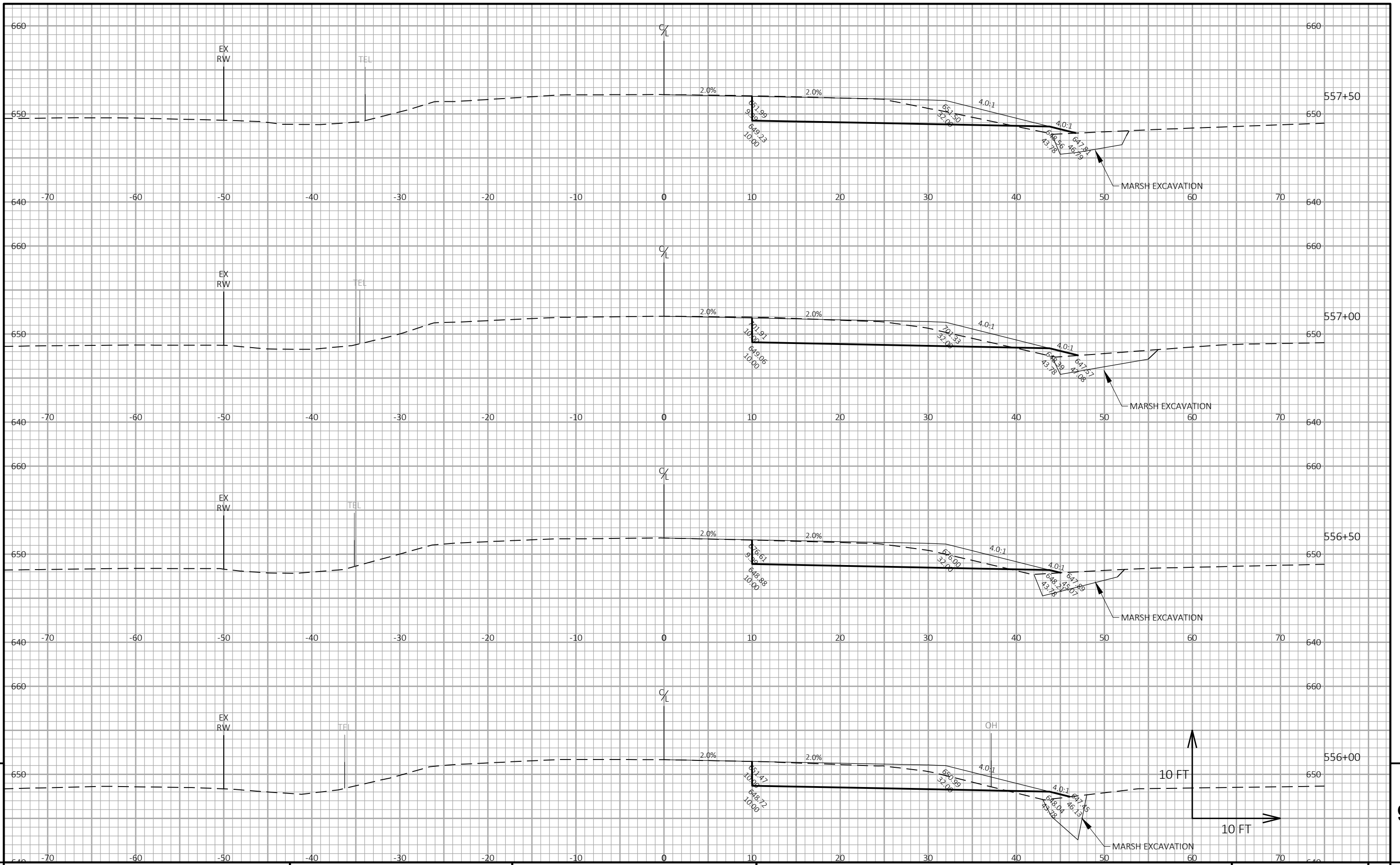

9

9

PROJECT NO: 1180-44-70	HWY: USH 2	COUNTY: ASHLAND & IRON	CROSS SECTIONS: CROSS SECTIONS	SHEET	E
------------------------	------------	------------------------	--------------------------------	-------	---

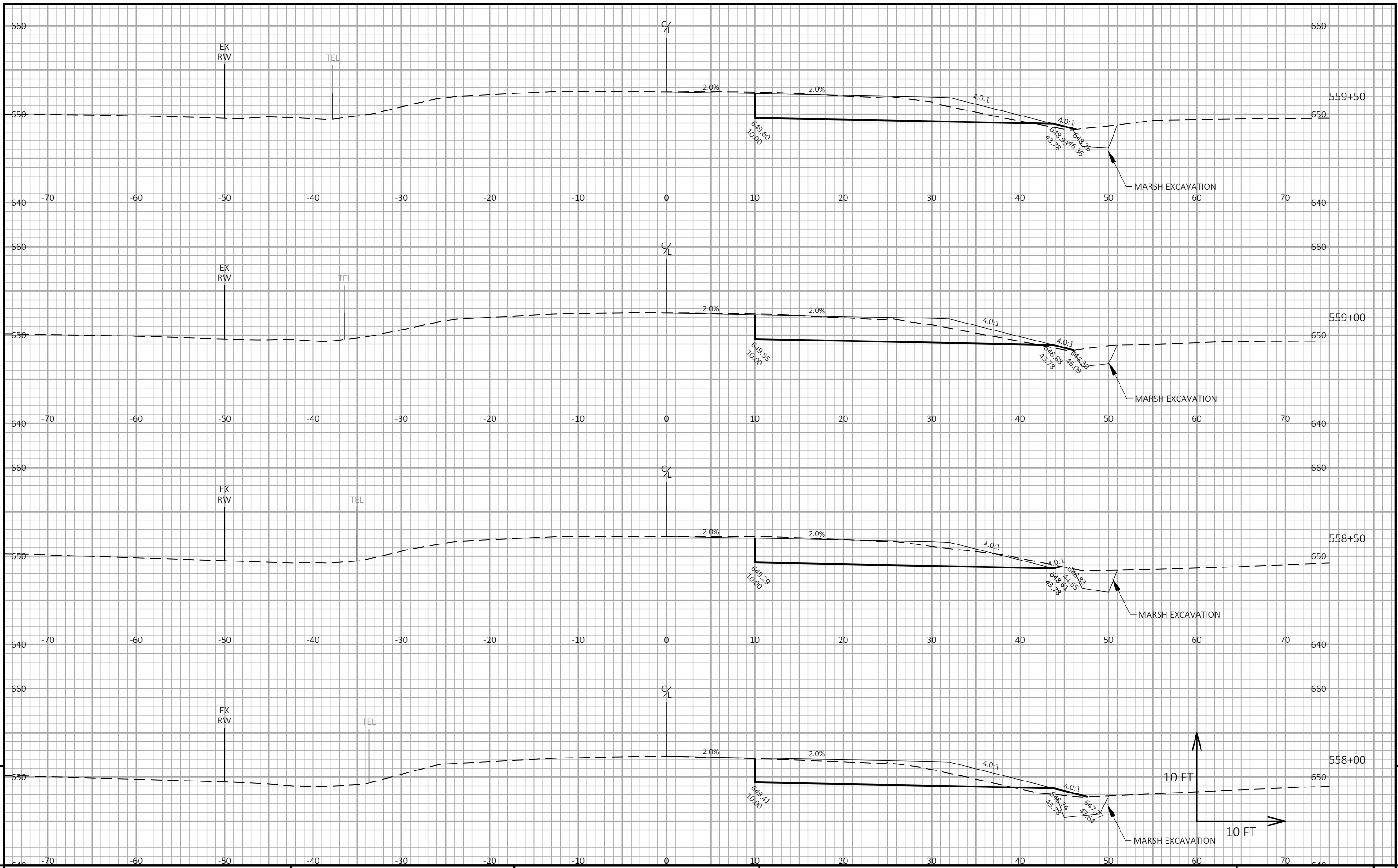

9

9

PROJECT NO: 1180-44-70	HWY: USH 2	COUNTY: ASHLAND & IRON	CROSS SECTIONS: CROSS SECTIONS	SHEET	E
------------------------	------------	------------------------	--------------------------------	-------	---

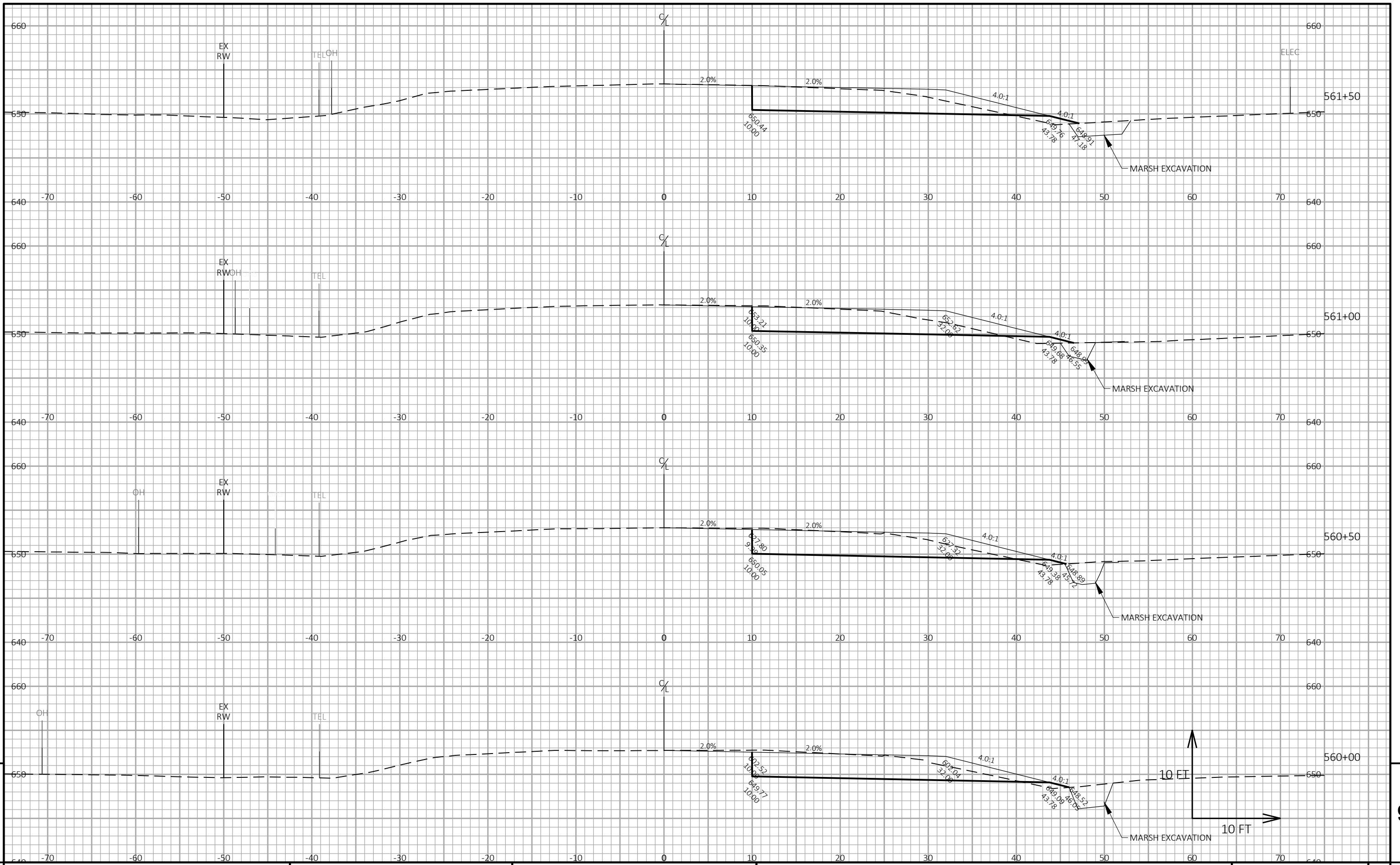

9

9

PROJECT NO: 1180-44-70	HWY: USH 2	COUNTY: ASHLAND & IRON	CROSS SECTIONS: CROSS SECTIONS	SHEET	E
------------------------	------------	------------------------	--------------------------------	-------	---

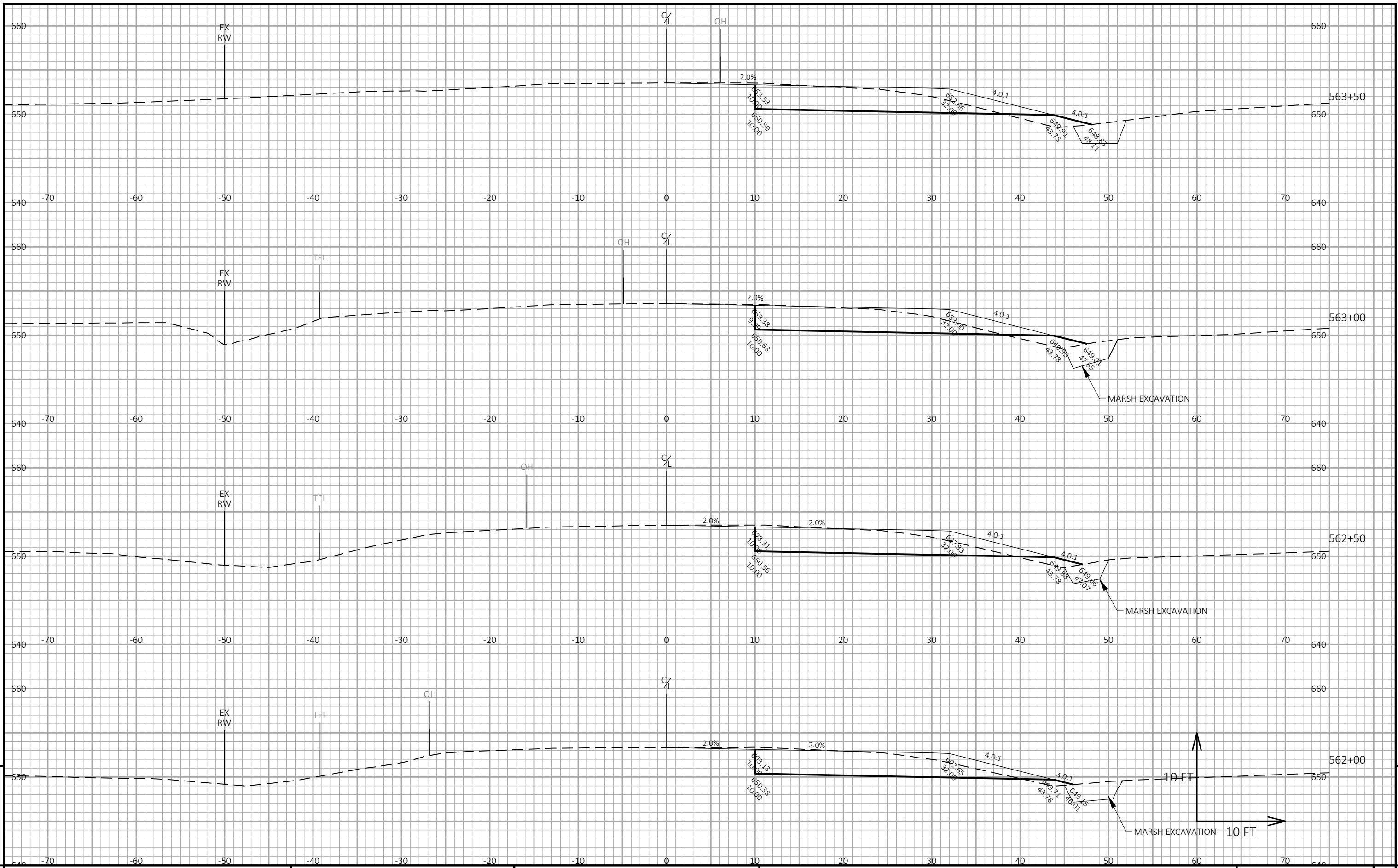

9

9

PROJECT NO: 1180-44-70 HWY: USH 2 COUNTY: ASHLAND & IRON CROSS SECTIONS: CROSS SECTIONS SHEET E

FILE NAME: N:\PDS\C3D\11804401\SHEETSPLAN\1180_44_01_XS.DWG PLOT DATE: 7/31/2022 9:02 PM PLOT BY: FINNEGAN, MITCHELL PLOT NAME: PLOT SCALE: 1 IN:10 FT HORZ. / 1 IN:10 FT VERT. WISDOT/CADD SHEET 49

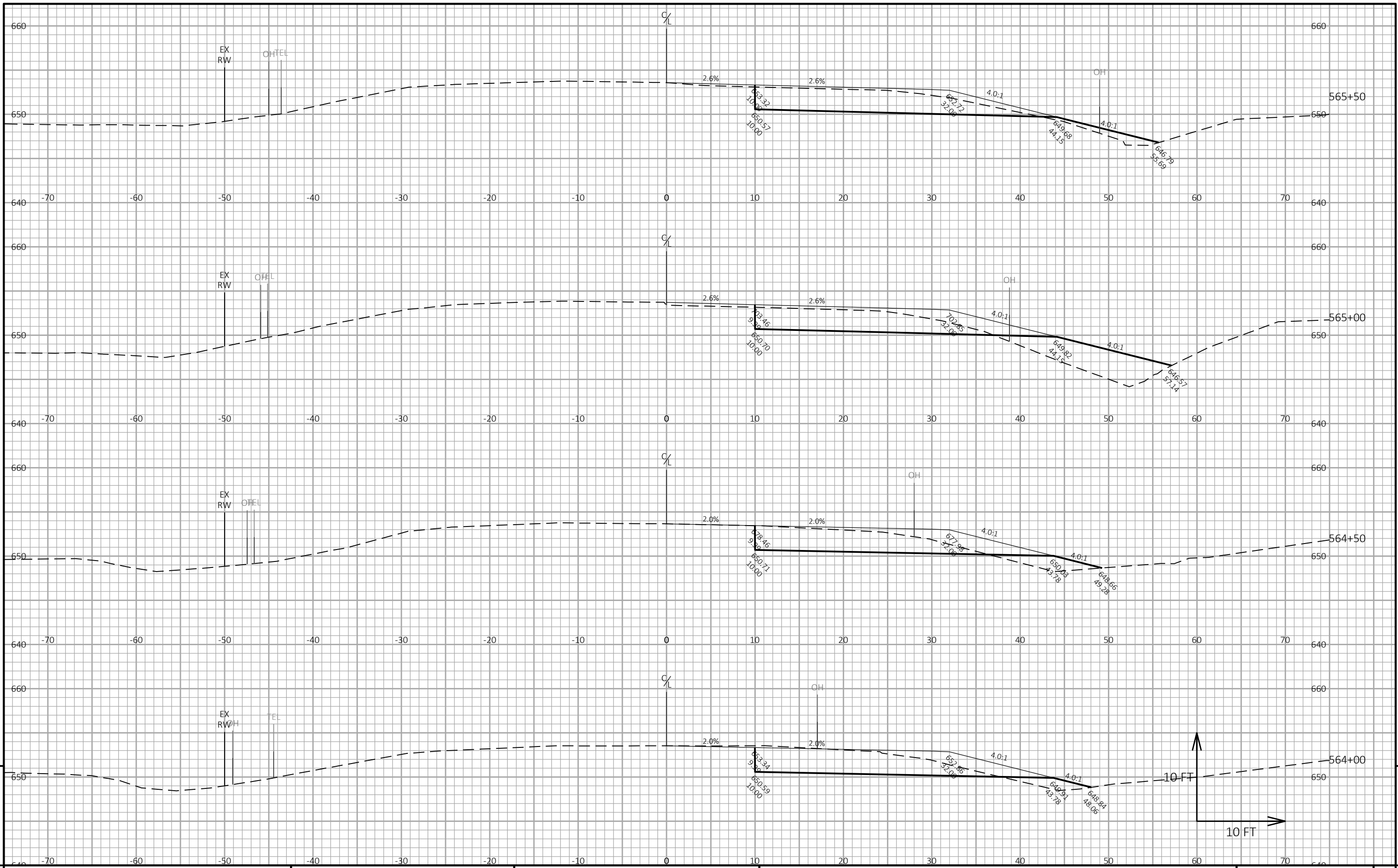

9

9

PROJECT NO: 1180-44-70	HWY: USH 2	COUNTY: ASHLAND & IRON	CROSS SECTIONS: CROSS SECTIONS	SHEET	E
------------------------	------------	------------------------	--------------------------------	-------	---

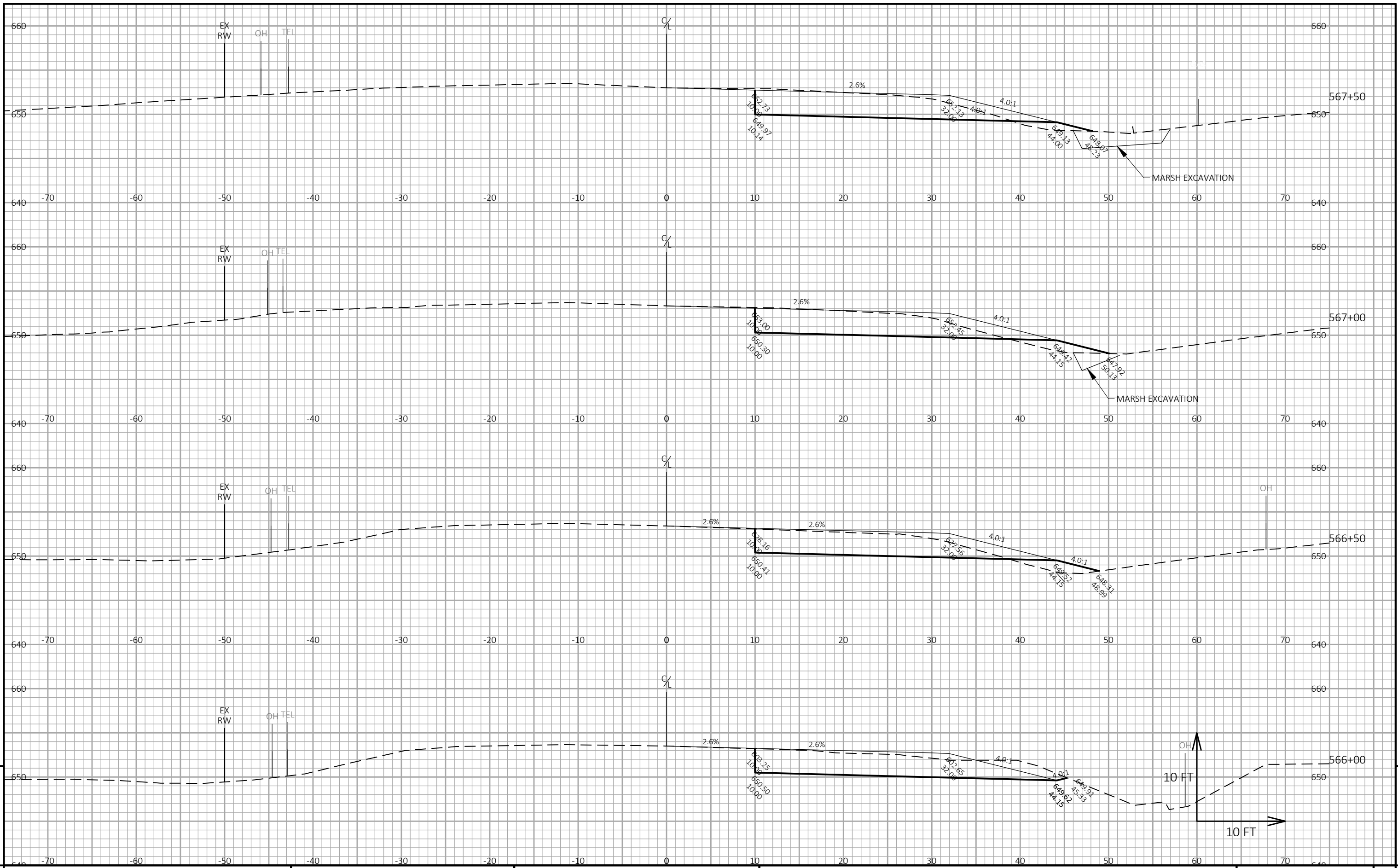

9

9

PROJECT NO: 1180-44-70	HWY: USH 2	COUNTY: ASHLAND & IRON	CROSS SECTIONS: CROSS SECTIONS	SHEET	E
------------------------	------------	------------------------	--------------------------------	-------	---

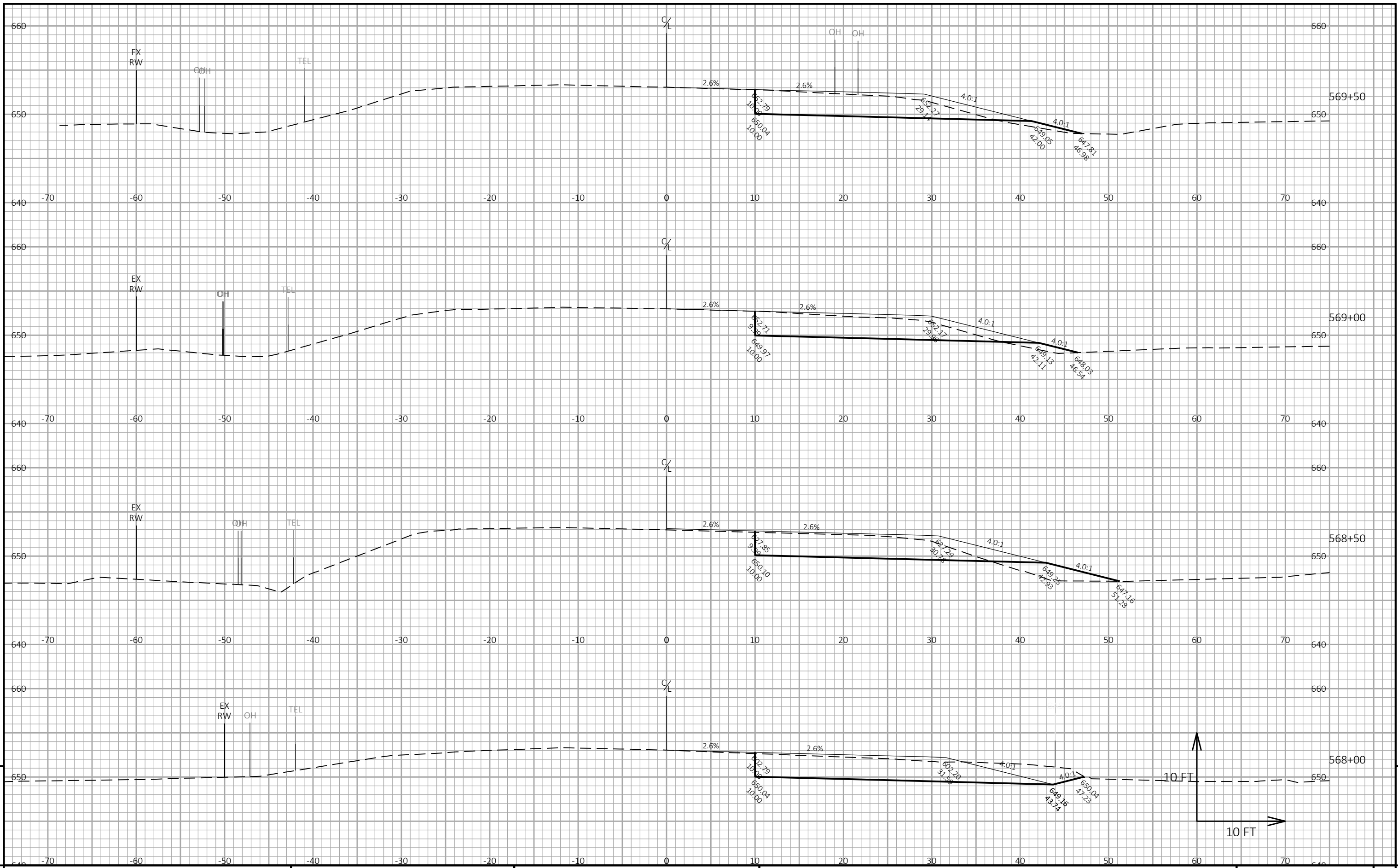

9

9

PROJECT NO: 1180-44-70 HWY: USH 2 COUNTY: ASHLAND & IRON CROSS SECTIONS: CROSS SECTIONS SHEET E

FILE NAME: N:\PDS\C3D\11804401\SHEETPLAN\1180_44_01_XS.DWG PLOT DATE: 7/31/2022 9:03 PM PLOT BY: FINNEGAN, MITCHELL PLOT NAME: PLOT SCALE: 1 IN:10 FT HORZ. / 1 IN:10 FT VERT. WISDOT/CADD SHEET 49

LAYOUT NAME - 13

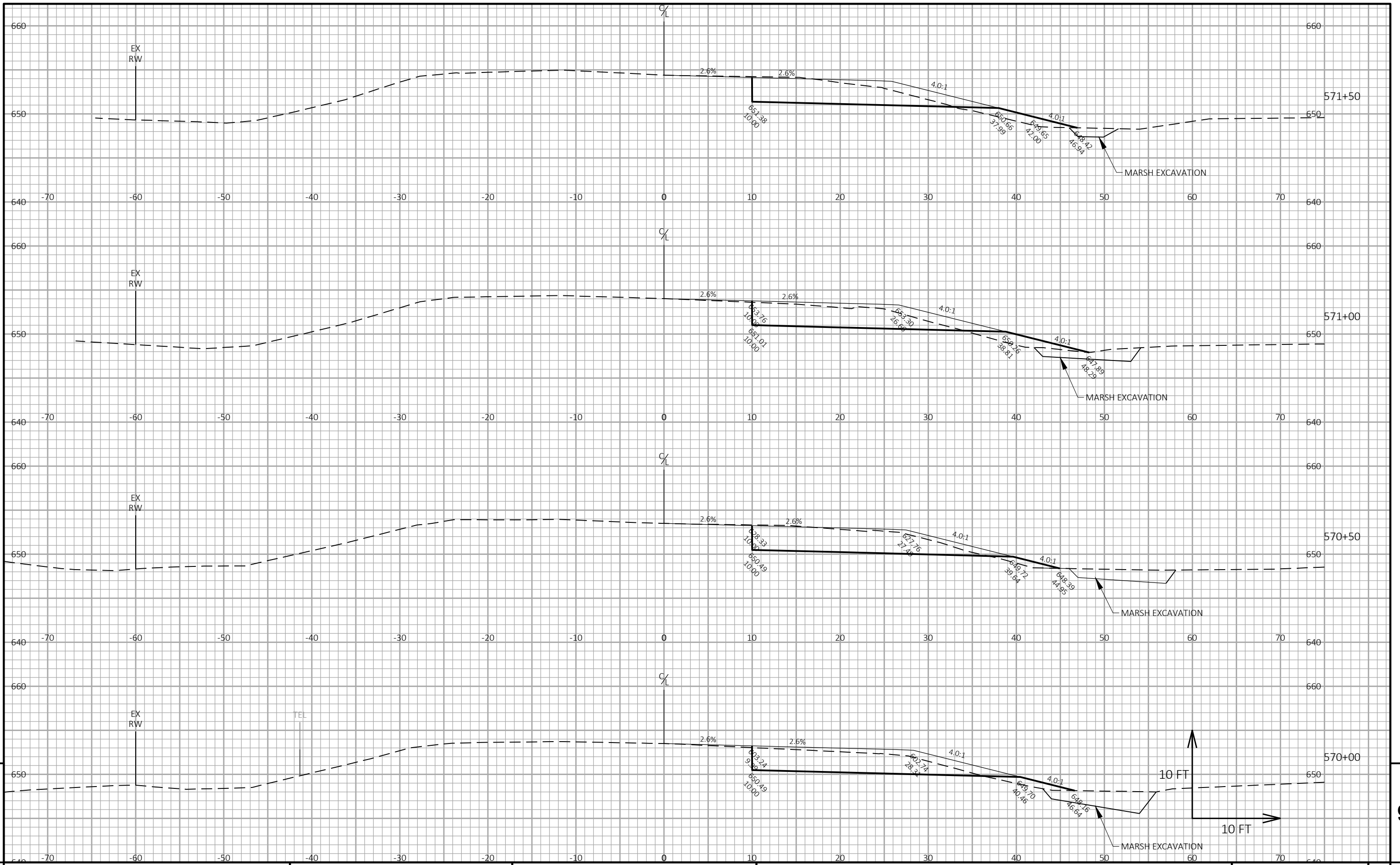

9

9

PROJECT NO: 1180-44-70	HWY: USH 2	COUNTY: ASHLAND & IRON	CROSS SECTIONS: CROSS SECTIONS	SHEET	E
------------------------	------------	------------------------	--------------------------------	-------	---

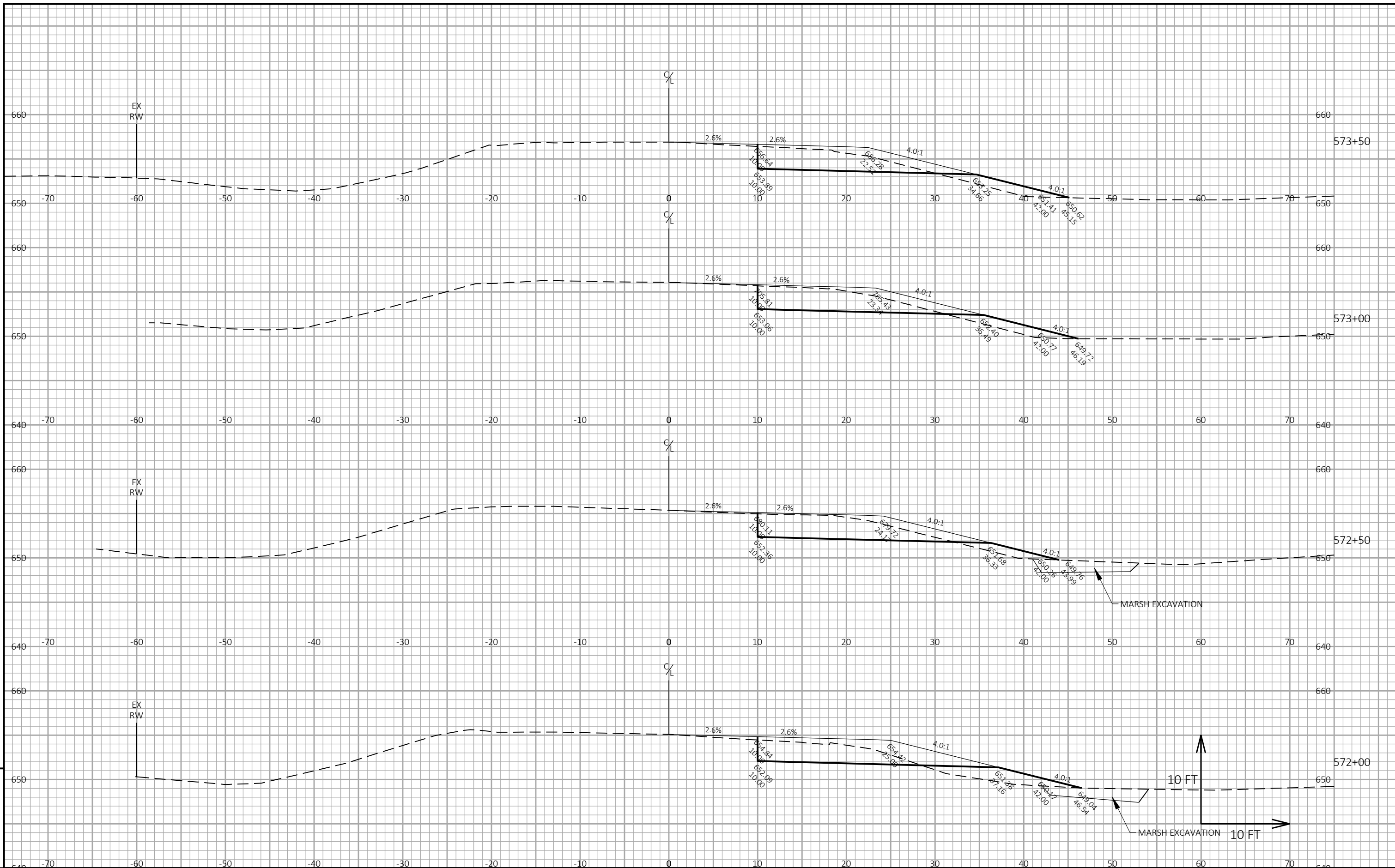

PROJECT NO: 1180-44-70

HWY: USH 2

COUNTY: ASHLAND & IRON

CROSS SECTIONS: CROSS SECTIONS

SHEET

E

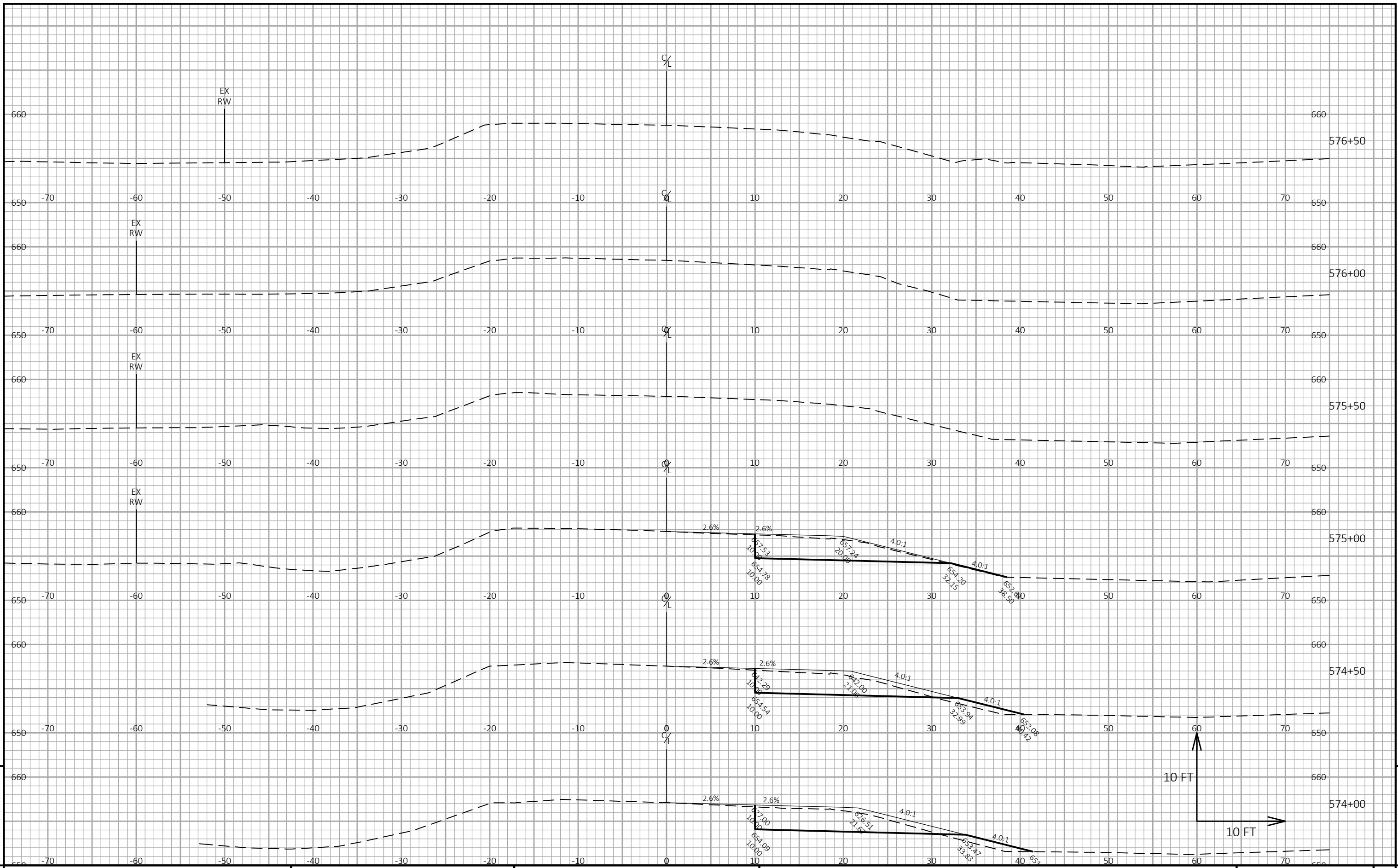

9

9

PROJECT NO: 1180-44-70 HWY: USH 2 COUNTY: ASHLAND & IRON CROSS SECTIONS: CROSS SECTIONS SHEET E

FILE NAME : N:\PDS\C3D\11804401\SHEETSP\1180_44_01_XS.DWG PLOT DATE : 7/31/2022 9:03 PM PLOT BY : FINNEGAN, MITCHELL PLOT NAME : PLOT SCALE : 1 IN:10 FT HORZ. / 1 IN:10 FT VERT. WISDOT/CADD SHEET 49

LAYOUT NAME - 16

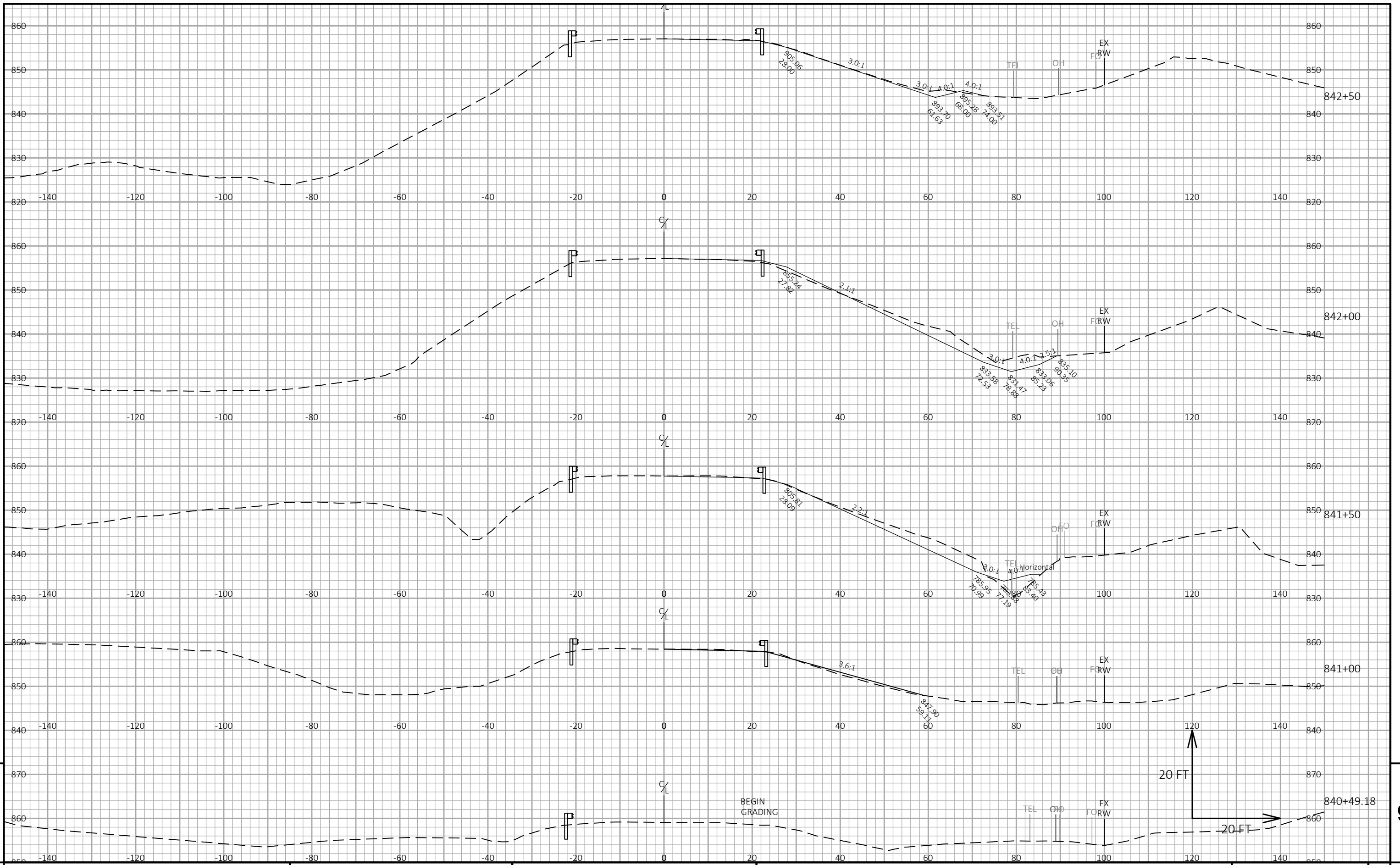

9

9

PROJECT NO: 1180-44-70 HWY: USH 2 COUNTY: ASHLAND & IRON CROSS SECTIONS: CROSS SECTIONS SHEET E

FILE NAME : N:\PDS\C3D\11804401\DESIGN\CORRIDORS\DENOMIE CREEK.DWG PLOT DATE : 7/31/2022 9:05 PM PLOT BY : FINNEGAN, MITCHELL PLOT NAME : PLOT SCALE : 1 IN:20 FT HORZ. / 1 IN:20 FT VERT. WISDOT/CADDs SHEET 49

LAYOUT NAME - 2

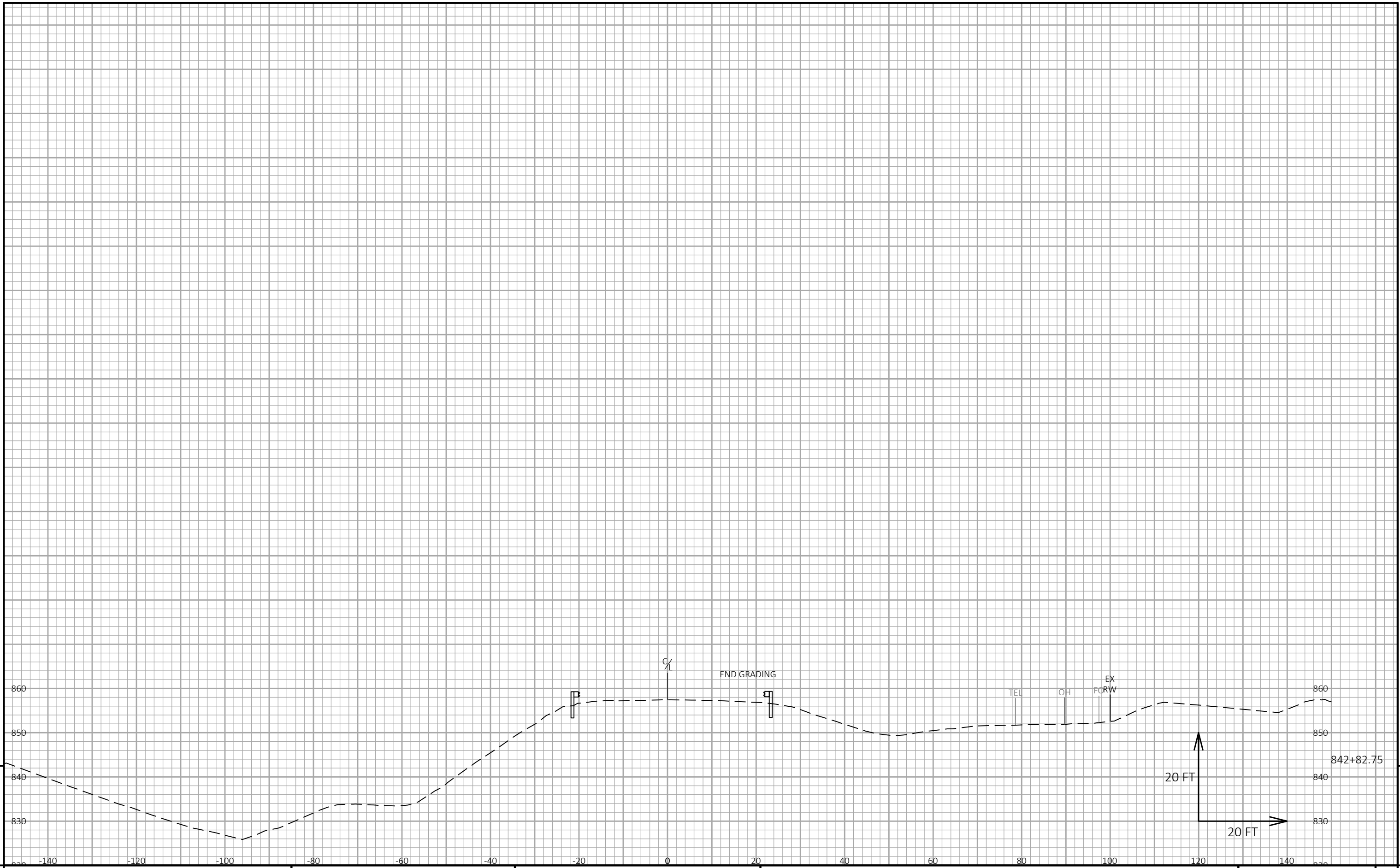

9

9

PROJECT NO: 1180-44-70	HWY: USH 2	COUNTY: ASHLAND & IRON	CROSS SECTIONS: CROSS SECTIONS	SHEET	E
------------------------	------------	------------------------	--------------------------------	-------	---

FILE NAME : N:\PDS\C3D\11804401\DESIGN\CORRIDORS\DENOMIE CREEK.DWG
LAYOUT NAME - 3

PLOT DATE : 7/31/2022 9:05 PM

PLOT BY : FINNEGAN, MITCHELL

PLOT NAME :

PLOT SCALE : 1 IN:20 FT HORZ. / 1 IN:20 FT VERT.

WISDOT/CADD SHEET 49

Notes



Wisconsin Department of Transportation

Dedicated people creating transportation solutions through innovation and exceptional service.

<http://www.dot.wisconsin.gov>